



# Linear Actuators

Linear Actuators for Industrial, Mobile and Structural Applications



DISTRIBUIDOR  
AUTORIZADO

MEX (55) 53 63 23 31    MTY (81) 83 54 10 18  
QRO (442) 1 95 72 60    ventas@industrialmagza.com

**THOMSON**<sup>®</sup>

*Linear Motion. Optimized.<sup>™</sup>*



*Linear Motion. Optimized.™*

## Thomson - the Choice for Optimized Motion Solutions

Often the ideal design solution is not about finding the fastest, sturdiest, most accurate or even the least expensive option. Rather, the ideal solution is the optimal balance of performance, life and cost.

### Quickly Configure the Optimal Mechanical Motion Solution

Thomson has several advantages that makes us the supplier of choice for motion control technology.

- Thomson owns the broadest standard product offering of mechanical motion technologies in the industry.
- Modified versions of standard product or white sheet design solutions are routine for us.
- Choose Thomson and gain access to over 70 years of global application experience in industries including packaging, factory automation, material handling, medical, clean energy, printing, automotive, machine tool, aerospace and defense.
- As part of Altra Industrial Motion, we are financially strong and unique in our ability to bring together control, drive, motor, power transmission and precision linear motion technologies.

### A Name You Can Trust

A wealth of product and application information as well as 3D models, software tools, our distributor locator and global contact information is available at [www.thomsonlinear.com/contact\\_us](http://www.thomsonlinear.com/contact_us). Talk to us early in the design process to see how Thomson can help identify the optimal balance of performance, life and cost for your next application. And, call us or any of our 2000+ distribution partners around the world for fast delivery of replacement parts.

### Local Support Around the Globe

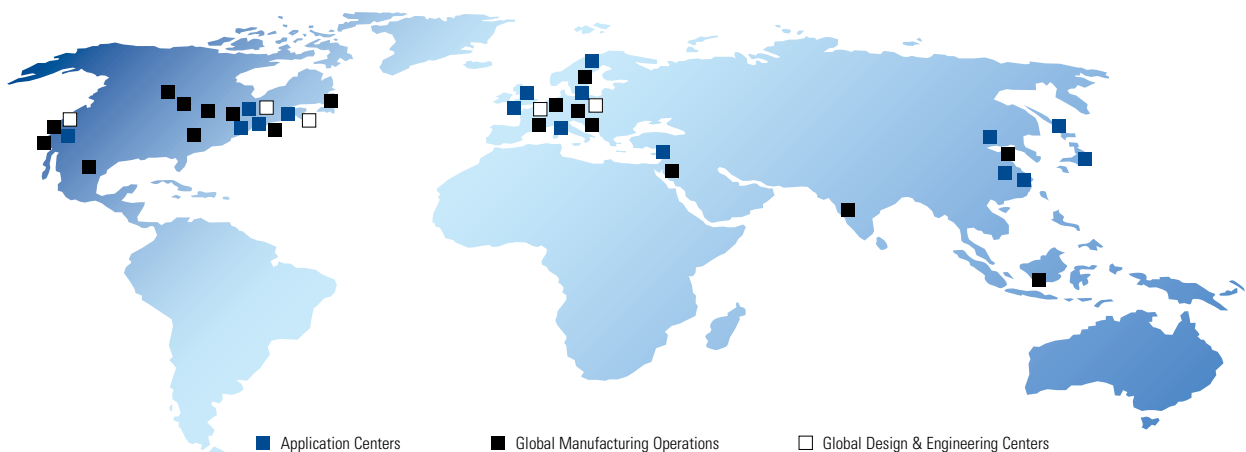

# Table of Contents

<b>Introduction .....</b>	<b>4</b>
Leveraging Decades of Design and Application Expertise .....	4
Why Choose Electric Linear Actuators? .....	6
Why Convert to Electric Actuators? .....	8
Smart Actuation.....	10
Applications.....	12
Online Sizing and Selection Tools .....	14
 <b>Performance Overview .....</b>	 <b>16</b>
 <b>Linear Actuators .....</b>	 <b>20</b>
Electrak® HD .....	20
Electrak GX DC.....	34
Electrak GX AC.....	44
Electrak LA14 .....	56
Electrak LA24.....	64
Electrak PPA.....	74
Max Jac® .....	82
Electrak 050 .....	88
Electrak 1 S.....	94
Electrak 1 SP.....	100
Electrak Throttle .....	106
WhisperTrak™ .....	114
 <b>Lifting Columns .....</b>	 <b>124</b>
DMHD .....	124
DMD.....	136
DMA.....	142
 <b>Rodless Actuators .....</b>	 <b>148</b>
LM80-H .....	148
LM80-V .....	154
 <b>Glossary.....</b>	 <b>160</b>

## Leveraging Decades of Design and Application Expertise

The history of Thomson actuators goes back to the mid-1960s when American engineers used ball screws to build the first generation of electric linear actuators. These were developed for control of accessory drives on garden tractors and farm equipment. Since that simple beginning, actuators are now used in all types of equipment to automate processes, remove people from dangerous situations, provide remote control, and make difficult, tedious or manual jobs easier.



**1967**

The first electric linear actuators, designed for agricultural equipment, are released.



**1974**

**First line of actuators** with parallel motors are released.



**1982**

The **Electrak 10** actuator line is released.



**1984**

**Electrak 1** - the miniature actuator is released.



**1991**

The first series of **lifting columns** are released.



Today, Thomson is the market leader for electric linear actuators used in the most demanding applications, including construction and agriculture vehicles. We routinely collaborate with OEMs globally to solve problems, boost efficiency and enhance the value passed on to their customers.

Call us today to discuss how our vast offering of standard or custom solutions can deliver the optimal balance of performance, life and installed cost for you and your applications.



Thomson actuators help people every day at home or work, during commuting, or when visiting the doctor, dentist or therapist.

**1999**  
**Electrak 050** is released.



**2000**  
The rodless **LM80 actuator** is released.



**2012**  
**WhisperTrak** is released.



**2013**  
**Electrak Throttle** and **Max Jac** are released.



**2016**  
**Electrak HD** is released.



**2019**  
**Electrak GX** is released.



## Why Choose Electric Linear Actuators?

Electric linear actuators are versatile, easy to use and affordable compared to most alternatives. As long as electric power is available, there is likely a suitable electric actuator for the job. The latest generation of actuators, which are smarter, stronger and sturdier, have also created new application possibilities. Where you once had to look for expensive, complex and often custom-built solutions, a standard electric actuator is often now the simple choice.

An electric actuator is often the easiest way to move from manual to powered motion since electricity is the easiest and most readily available power source. It doesn't matter if electricity is from the grid, a battery or any other source since there are actuators for both AC or DC in all the most common voltages. Plug in and run - it is often as simple as that.

### **Smaller, Stronger and More Robust**

Electric motors, drives and batteries have experienced huge technological leaps forward over the past few decades, and the trend of making electric actuators more powerful and efficient continues. At the same time, actuators have become better sealed and more robust, allowing them to be used in even the toughest environments.

### **Clean, Maintenance-Free Operation**

Electric actuators are inherently clean since there are no messy compressors, filters, oils or other mediums involved. Most of them are, in fact, clean enough to be used in areas sensitive to contamination out of the box. Thomson electric actuators are also completely maintenance free - there is no need to remember to check or replace anything. Electric actuators don't carry hidden ownership costs, sparing you of any unpleasant surprises throughout their lifetime.



Modern actuators can work in almost any environment

### Smart Actuation

At Thomson, the most advanced actuators today are known as “smart.” These models are integrated with onboard controls, which enable enhanced control functions that previously required complex external controls. They feature enhanced controllability and allow you to monitor performance and diagnostics to help increase efficiency and productivity.

### Affordable Actuation

Linear actuators are a cost-efficient alternative to other actuator technologies for many reasons:

- Electric power costs less than hydraulic or pneumatic power.  
Electric actuators only need energy when moving; at a standstill, they are self locking and need no power to keep the position.
- Cables are less expensive than tubes and hoses.
- Cables are a lot quicker and easier to install and commission.
- An electric actuator system is lightweight and requires little space.
- Less or eliminated maintenance reduces total cost of ownership.

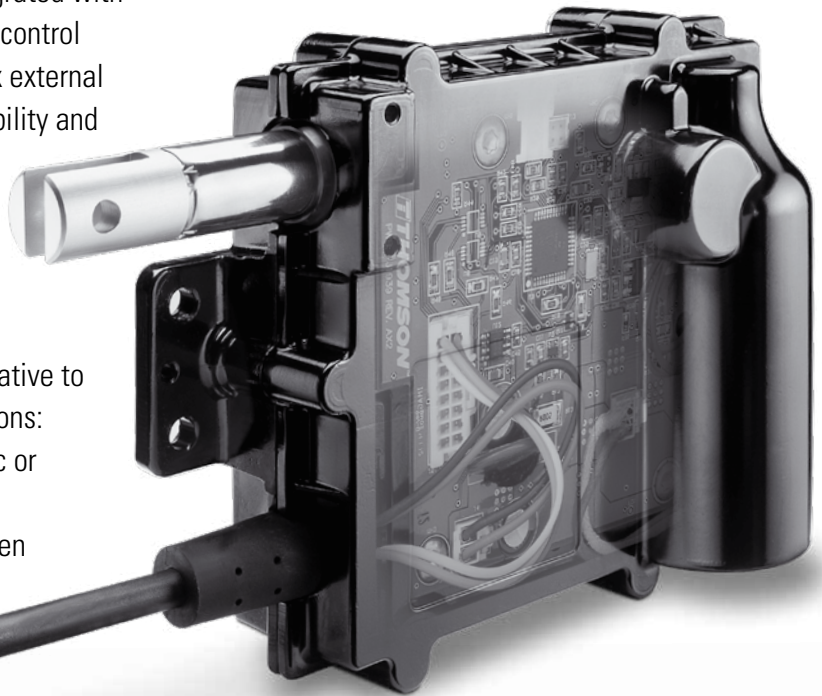

The “smart” Electrak® HD and Electrak Throttle actuators

## Why Convert to Electric Actuators?

There are many reasons to switch from a pneumatic or hydraulic actuator solution to an electric one. Better controllability, reduced complexity and a smaller footprint are often the main ones. Less energy consumption, cleaner operation and reduced maintenance are others but often you will also experience additional benefits such as better performance, reduced downtime, and faster assembly and commissioning.

### Better Controllability

An electric motor and a lead screw are much easier to run than a pneumatic or hydraulic cylinder, since essentially all you need to do is plug it in. They are also easier to control precisely since they react faster, are more accurate and do not suffer from creep at standstill or power off. In addition, they are easier to equip with onboard feedback and controls, making them easy to connect to other controls.

### Modular Control Concept

State-of-the-art electric actuators, such as the Thomson Electrak® HD, have a modular control architecture and can be ordered with anything from a simple motor to full bus communication functionality that let you control and monitor every aspect of the actuator and its performance.

### Reduced Costs and Improved Environment

There are many reasons why electric actuators can help you both save money and improve the environment, including:

- Increased energy efficiency and environment-friendly features.
- No need for costly compressors and the supporting infrastructure.
- Cleaner and safer to use in places sensitive to contamination.
- No risk of leaks – small, undetected leakages add hidden costs, while larger leaks can be hazardous, messy and costly.
- No maintenance required, reliable and easy to replace if necessary.
- Quick and simple to install and commission.

# ELECTRIC LINEAR ACTUATORS

**IMPROVE**

**EFFICIENCY  
RELIABILITY  
PRODUCTIVITY  
PERFORMANCE  
CONTROLLABILITY**

**REDUCE**

**COMPLEXITY  
ENGINEERING  
COMPONENTS  
OVERALL COSTS  
INSTALLATION TIME**



**Reduced Complexity and Smaller Footprint**

The illustration below compares three common, simple ways to run an electric actuator, a pneumatic cylinder and a hydraulic cylinder back and forth.

It appears obvious that both the pneumatic and hydraulic cylinder require more complex, space-demanding solutions that add more weight to the complete system.

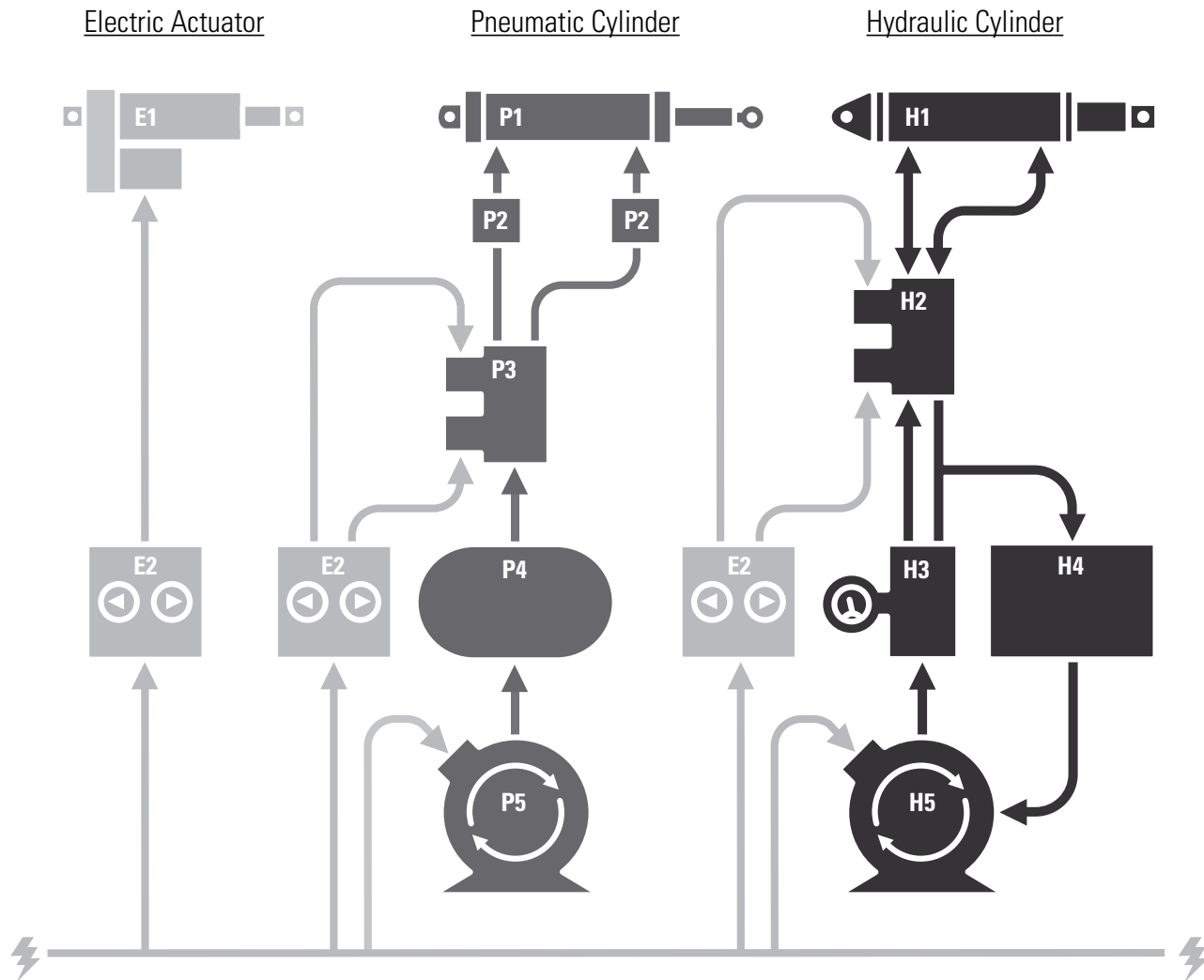

- E1. Electric linear actuator
- E2. Electric switches

- P1. Pneumatic cylinder
- P2. One-way flow control valves
- P3. Bidirectional valve
- P4. Compressed air tank
- P5. Pneumatic air compressor

- H1. Hydraulic cylinder
- H2. Bidirectional valve
- H3. Pressure relief valve
- H4. Hydraulic oil reservoir tank
- H5. Hydraulic oil compressor

## Smart Actuators

As the industrial world becomes increasingly connected, the designer's need for intelligent components that can communicate with each other and operate without the need for manual interaction is growing. Thomson is meeting this demand and helping to usher in a new generation of "smart" actuators where a modular onboard control architecture and the possibility to use bus communication are key features.

### Smart Actuator Benefits

- Increased efficiency and productivity.
- Fewer components and less cabling.
- Minimized complexity and easier installation.
- Reduced hardware and software costs.
- Decreased machine development time.
- Reduced overall system weight.
- Improved machine functionality and performance.
- Bus communication between host control and actuators.
- Synchronized actuator motion without having to add any extra external controls.
- Better and more accurate controllability.
- Speed and force control.
- Enhanced diagnostic and monitoring capabilities.

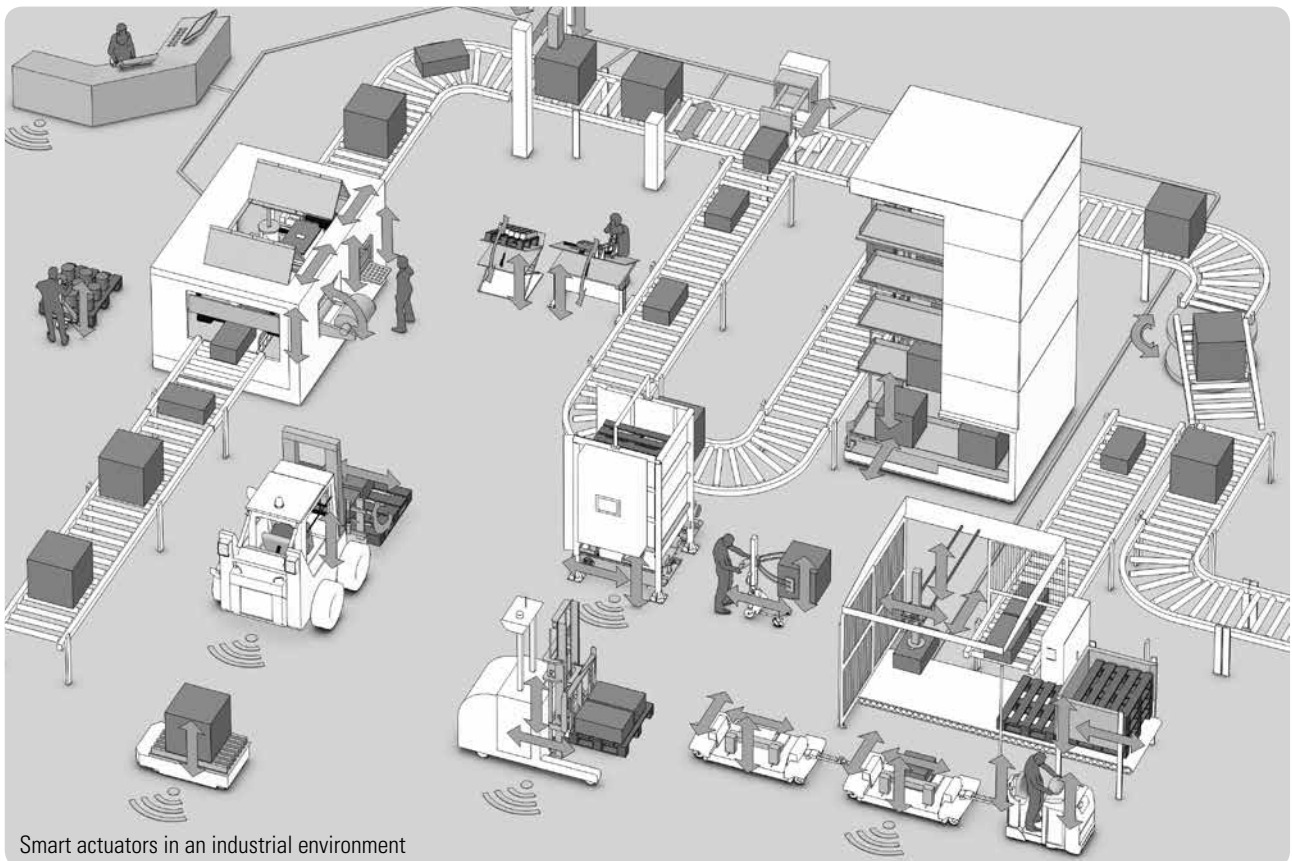

Smart actuators in an industrial environment

**Learn more about smart actuators at [www.thomsonlinear.com/smart](http://www.thomsonlinear.com/smart)**

### Traditional vs. Smart Systems

#### Traditional System

Each actuator is controlled by the host individually. By using control boxes, switches, sensors and position feedback devices, the host controls and keeps track of each actuator.

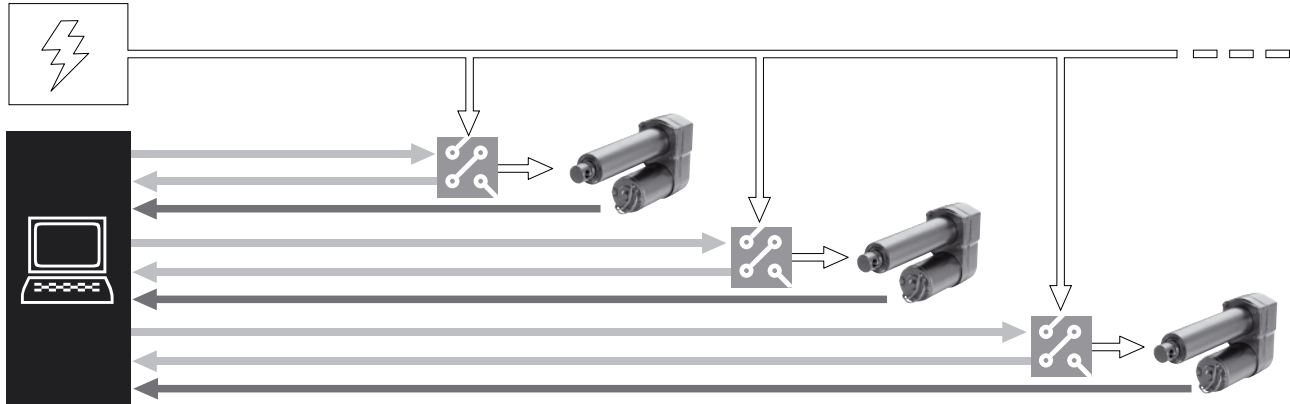

#### Bus Communication System



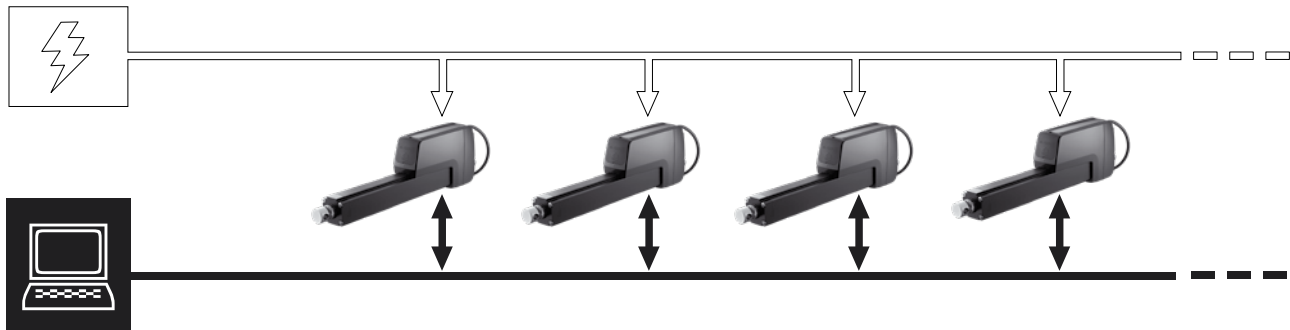

All actuators speak to the host control over the same bus, and each actuator does what it is commanded to and reports back when done or if something goes wrong.

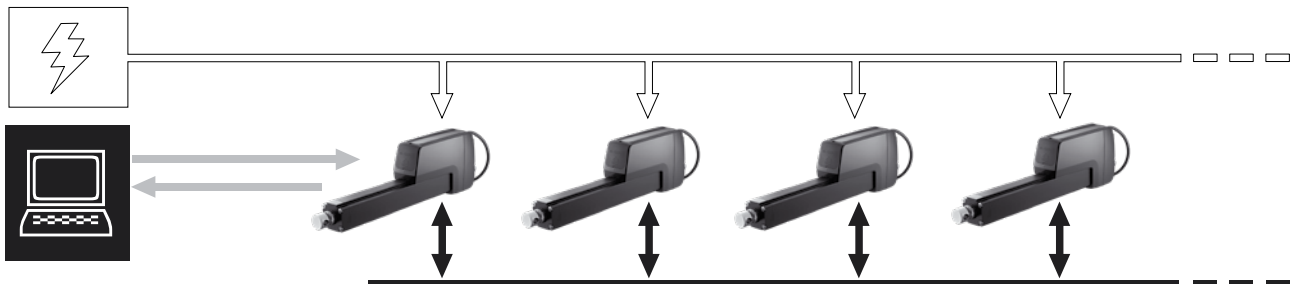

#### Synchronization System

The host control runs one actuator, which becomes the master. The other actuators follow the master as slaves without having to communicate with the host control.



-  Power lines
-  Control signals
-  Position feedback signals
-  Bus communication

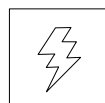

Power supply



Control box



Host control

## Applications

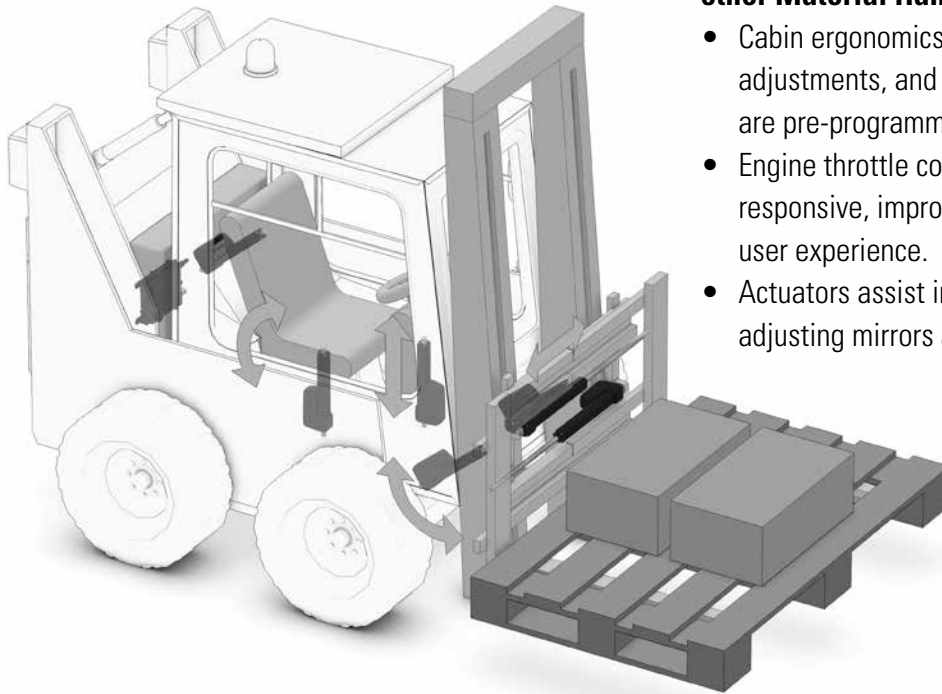

### Lifting Devices, Fork Lifts, Driver Cabins and other Material Handling Vehicles

- Cabin ergonomics are improved with seat adjustments, and individual, user-defined settings are pre-programmed for quick changes.
- Engine throttle control is more precise and responsive, improving fuel consumption and the user experience.
- Actuators assist in opening hoods and doors, and adjusting mirrors and ladders.

### Combines and other Agricultural Vehicles

- Electromechanical actuation is ideal for hard-to-reach places that may require complex control to function.
- Integrated electronics allow you to drop in an actuator where a more complicated control scheme for hydraulics or air would have been previously.
- Common applications include sieve leveling, auger tube fold, hood lift and grain bin cover.

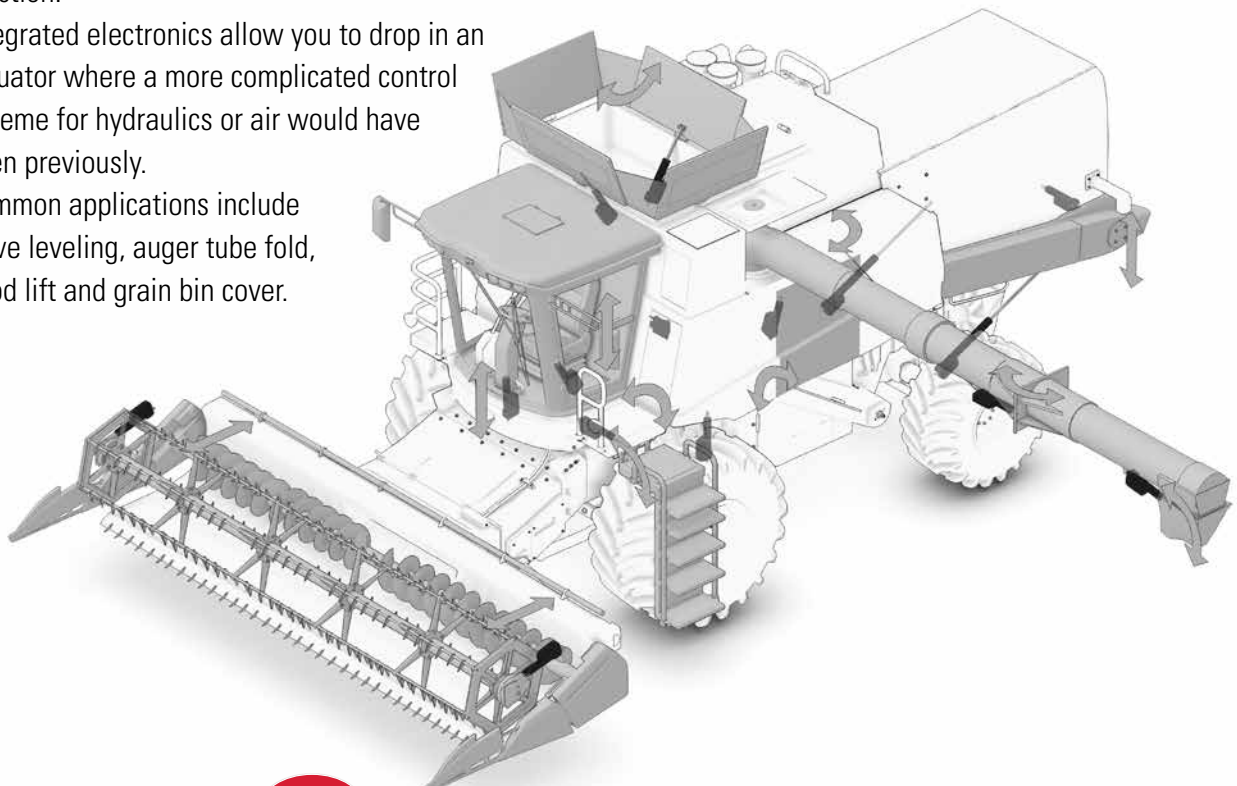

### Trains, Trams, Buses and other Public Transportation

- Electric actuators are more environmentally friendly and cost effective than hydraulic and pneumatic systems.
- Trains and buses using actuators for pantographs benefit from the robust construction to achieve long life in harsh environments.
- Overload sense and confirmed position are vital to user safety.
- Other public transport applications include door actuation, step leveling and gap control.

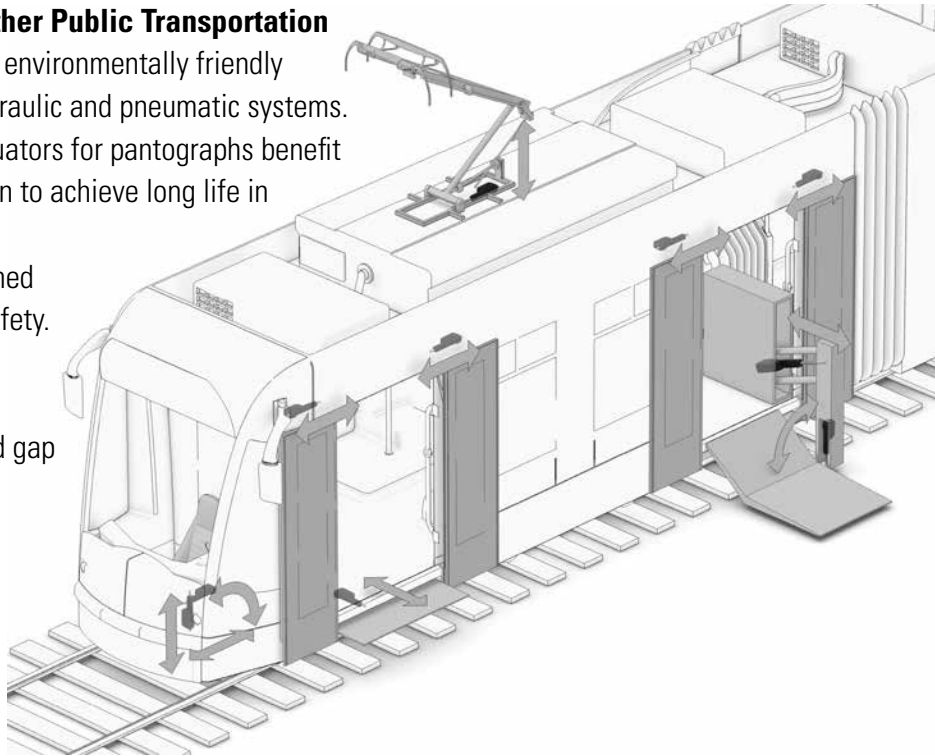

### Staircase Lifts, Patient Lifts and Wheel Chairs

- Used typically in homes, offices, mobile equipment or where electricity is the only available power source.
- Electric actuators are ideal for many lift functions depending on the style and configuration.
- Examples include seat leveling, tilting of the seat and foot rest, and extending and retracting the rail at the end of the staircase.

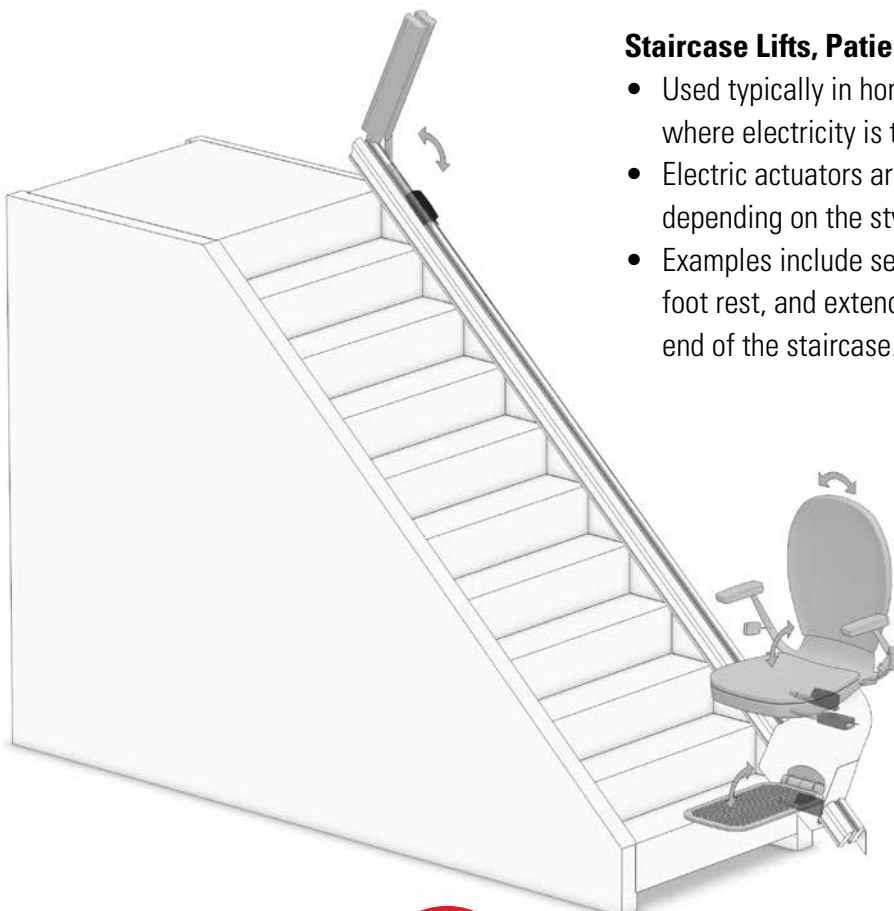

## Online Sizing and Selection Tools

Thomson LinearMotioneering® for Linear Actuators is a self-service, online sizing and selection tool that saves you time and cost and helps avoid misapplication. It allows you to quickly and accurately find your ideal solution by completing a self-guided, interactive series of questions that taps into the extensive application engineering knowledge base of Thomson experts.

LinearMotioneering is an easy-to-use, step-by-step tool that gathers all necessary information and then presents you with suitable solutions. Once the best candidate among the options is defined, LinearMotioneering will let you download all of the technical data and a 3D CAD model of the selected actuator, show you the cost and delivery time, and even let you purchase it from the Thomson online store.

### Your Own Project Library

All of your projects are stored in your own library so that you can return and continue working on them

or use an old project as the basis for a new one. Since projects are stored online, you can open them from any computer, mobile phone or tablet - from anywhere in the world

### Help with Custom Solutions

If LinearMotioneering can't find a suitable actuator for your project, you have the option to ask for a custom solution. The tool will ask for the necessary data so that our engineers can have a look and help you get what you need.

HOME | ABOUT US | FIND A DISTRIBUTOR | NEWSROOM | PARTNERS | CONTACT US | REGION: EUROPE SETTINGS LOGIN

**THOMSON**  
Linear Motion. Optimized.

Home learn more support my projects

---

**Linear MOTIONEERING®**  
**LINEAR ACTUATORS**

Size and Select Your System

START > **SIZING & SELECTION** > SOLUTIONS COMPARISON > OPTIONS & ACCESSORIES > BILL OF MATERIAL

**Step 1 - Fundamentals**

<p><b>Dynamic Force</b> ?</p> <input type="text" value="Max. required push/pull force at motion [N]"/> [N] <small>(Min: 0N , Max: 20000N)</small>	<p><b>Static Force</b> ?</p> <input type="text" value="Max. required holding force at stand still [N]"/> [N] <small>(Min: 0N , Max: 20000N)</small>
<p><b>Max. Stroke Length</b> ?</p> <input type="text" value="Max. required stroke [mm]"/> [mm] <small>(Min: 0mm , Max: 1500mm)</small>	<p><b>Actuator Supply Voltage</b> ?</p> <input type="text" value=""/>

**Environmental Conditions** (select best match) ?

 Standard Factory – IP55

1      2      3

**Solutions Based on Application Type** ?

Solutions by Family

**Do you want help to size and select the best match for your application?**  
Please visit: [www.linearactuators.linearmotioneering.com](http://www.linearactuators.linearmotioneering.com)

Thomson offers a wide variety of online resources to help you learn more about electric linear actuators. An experienced team of application engineers is also available to help you. To explore additional technical resources and options, contact Thomson customer support at [www.thomsonlinear.com/cs](http://www.thomsonlinear.com/cs).

### Smart Actuators Product Website

Learn more about smart actuators and how they can help you build better machines at: [www.thomsonlinear.com/smart](http://www.thomsonlinear.com/smart)

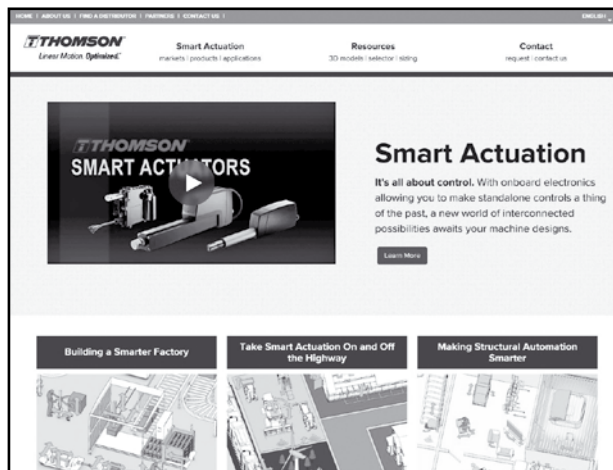

### Free CAD Models

Download free interactive 3D CAD models in the most common CAD formats at: [www.thomsonlinear.com/en/products/linear-actuators-drawings](http://www.thomsonlinear.com/en/products/linear-actuators-drawings)

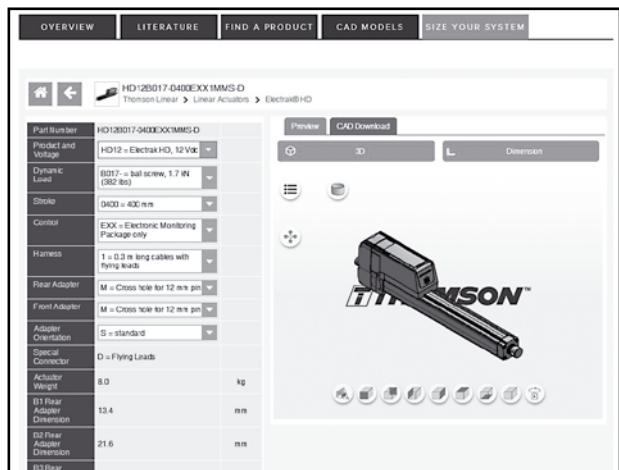

### Electrak® HD Product Website

Get additional information and learn more about Electrak HD at: [www.thomsonlinear.com/hd](http://www.thomsonlinear.com/hd)

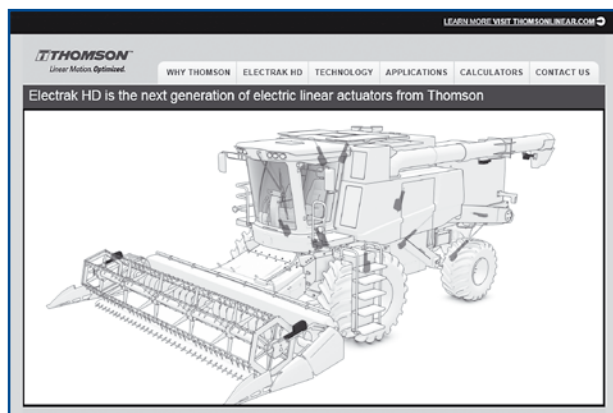

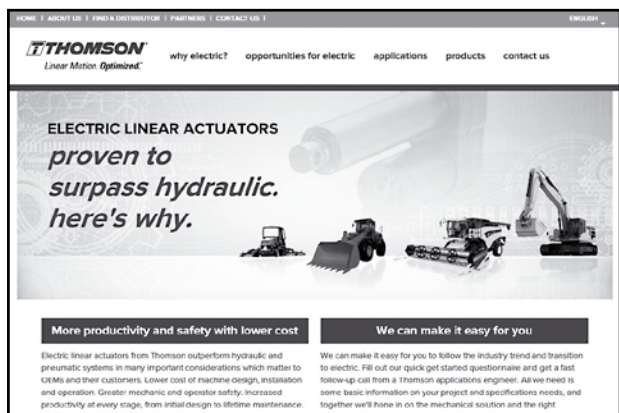

### Mobile Off-Highway Product Website

Learn how actuators can be used in mobile off-highway vehicles at: [www.thomsonlinear.com/moh](http://www.thomsonlinear.com/moh)





## Specifications

	<b>Electrak® HD</b>	<b>Electrak® GX DC</b>	<b>Electrak® GX AC</b>	
				
Screw type	ball	acme or ball	acme or ball	
Manual operation	yes	optional	optional	
Static load holding	yes	yes	yes	
End-of-stroke protection	internal limit switches	clutch	clutch	
Overload protection	yes	yes	yes	
Available input voltages	[Vdc] [Vac]	12, 24 -	- 1 × 115, 1 × 230, 3 × 400	
Max. static load <sup>(1)</sup>	[N (lbf)]	18000 (4000)	18000 (4000)	
Max. dynamic load (Fx)	[N (lbf)]	16000 (3584)	9000 (2000)	
Max. speed @ no load/max. load	[mm/s (in/s)]	71/58 (2.80/2.28)	61/37 (2.40/1.40)	
Max. ordering stroke (S) length	[mm] / [in]	1000 / -	- / 24	
Restraining torque	[Nm (lbf-in)]	0	11.3 (100)	
Operating temperature limits	[°C (F)]	- 40 – 85 (- 40 – 185)	- 25 – 65 (- 15 – 150)	
Full load duty cycle @ 25 °C (77 °F)	[%]	25	25	
Ingress protection rating - static		IP67 / IP69K	IP66 / IP69K	
Control options	<ul style="list-style-type: none"> <li>• End-of-stroke output</li> <li>• Analog position feedback</li> <li>• Digital position feedback</li> <li>• Low-level switching</li> <li>• Synchronization</li> <li>• CAN bus J1939</li> </ul>	<ul style="list-style-type: none"> <li>• Analog position feedback</li> </ul>	<ul style="list-style-type: none"> <li>• Analog position feedback</li> </ul>	
Page	20	34	44	



**Do you want help to size and select the best match for your application?  
LinearMotioneering will guide you through the whole process!  
[www.linearactuators.linearmotioneering.com](http://www.linearactuators.linearmotioneering.com)**







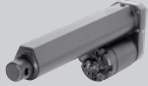

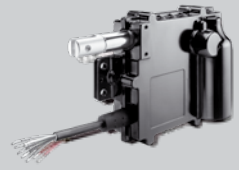
	<b>Electrak® LA14</b>	<b>Electrak® LA24</b>	<b>Electrak® PPA</b>	<b>Max Jac</b>	<b>Electrak® 050</b>
					
	acme or ball	acme or ball	ball	worm or ball	worm
	optional	optional	no	no	no
	yes	yes	yes	worm yes, ball no	yes
	clutch	clutch	clutch	no	clutch
	yes	yes	yes	no	yes
	12, 24, 36 -	- 1 × 115, 1 × 230, 3 × 400	12, 24, 36 -	12, 24 -	12, 24, 36 -
	18000 (4000)	18000 (4000)	13350 (3000)	2000 (450)	1020 (224)
	6800 (1500)	6800 (1500)	6670 (1500)	800 (180)	510 (112)
	61/37 (2.40/1.40)	53/43 (2.10/1.70)	32/28 (1.26/1.10)	60 / 30 (2.4 / 1.2)	48 / 37 (1.9 / 1.5)
	600 / -	600 / -	- / 36	300 / -	200 / -
	0	0	22 (200)	2 (1.48)	0
	- 25 – 65 (- 15 – 150)	- 25 – 65 (- 15 – 150)	- 25 – 65 (- 15 – 150)	- 40 – 85 (- 40 – 185)	- 30 – 80 (- 22 – 176)
	25	25	30	25	25
	IP65	IP45	IP54	IP66/IP69K	IP56
	<ul style="list-style-type: none"> <li>• Analog position feedback</li> </ul>	<ul style="list-style-type: none"> <li>• Analog position feedback</li> </ul>	<ul style="list-style-type: none"> <li>• End-of-stroke limit switches</li> <li>• Analog position feedback</li> </ul>	<ul style="list-style-type: none"> <li>• Analog position feedback</li> <li>• Digital position feedback</li> </ul>	<ul style="list-style-type: none"> <li>• End-of-stroke limit switches</li> <li>• Analog position feedback</li> </ul>
	56	64	74	82	88

**Do you want help to size and select the best match for your application?  
LinearMotioneering will guide you through the whole process!  
[www.linearactuators.linearmotioneering.com](http://www.linearactuators.linearmotioneering.com)**

# Performance Overview

Specifications				
	Electrak® 1 S	Electrak® 1 SP	Electrak® Throttle	
				
Screw type	acme	acme	worm	
Manual operation	no	no	no	
Static load holding	yes	yes	yes	
End-of-stroke protection	internal limit switches	no	current sensing	
Overload protection	yes	yes	yes	
Available input voltages	[Vdc] [Vac]	12, 24 -	12, 24 -	
Max. static load <sup>(1)</sup>	[N (lbf)]	1300 (300)	1300 (300)	260 (60)
Max. dynamic load (Fx)	[N (lbf)]	340 (75)	340 (75)	130 (30)
Speed @ no load/max. load	[mm/s (in/s)]	78/64 (3.1/2.5)	78/64 (3.1/2.5)	96/83 (3.7/3.3)
Max. ordering stroke (S) length	[mm]	- / 8	- / 8	- / 2
Restraining torque	[Nm (lbf-in)]	2.3 (1.7)	2.3 (1.7)	0
Operating temperature limits	[°C (F)]	- 25 – 65 (- 13 – 150)	- 25 – 65 (- 13 – 150)	- 40 – 125 (- 40 – 257)
Full load duty cycle @ 25 °C (77 °F)	[%]	25	25	50
Ingress protection rating - static		IP66	IP66	IP69K, IP67
Control options	-		<ul style="list-style-type: none"> <li>• Analog position feedback</li> </ul>	<ul style="list-style-type: none"> <li>• Analog position feedback</li> <li>• Internal-end-of- stroke limit switches</li> <li>• CAN bus J1939</li> </ul>
Page		94	100	106

**Do you want help to size and select the best match for your application?  
LinearMotioneering will guide you through the whole process!  
[www.linearactuators.linearmotioneering.com](http://www.linearactuators.linearmotioneering.com)**

	WhisperTrak™	DMHD	DMD	DMA	LM80H	LM80V
						
	acme	ball	acme or ball	acme or ball	trapezoidal or ball	trapezoidal or ball
	no	yes	optional	optional	no	no
	yes	yes	yes	yes	no	no
	no	internal limit switches	clutch	clutch	spring loaded soft stop	spring loaded soft stop
	no	yes	yes	yes	no	no
	12, 24 -	12, 24 -	12, 24 -	- 1 × 230, 3 × 400	12, 24 -	12, 24 -
	4000 (900)	18000 (4000)	18000 (4000)	18000 (4000)	2000 (450)	2000 (450)
	4000 (900)	16000 (2248)	6800 (1500)	6800 (1500)	750 (169)	750 (169)
	11.0/8.0 (0.43/0.31)	71/58 (2.80/2.28)	61/37 (2.40/1.40)	53/43 (2.10/1.70)	110/73 (4.3/2.9)	110/83 (4.3/3.3)
	50 / -	600 / -	600 / -	600 / -	1500 / -	1500 / -
	0	0	0	0	0	0
	-25 – 40 (-13 – 104)	- 40 – 85 (- 40 – 185)	- 25 – 85 (- 15 – 185)	- 25 – 65 (- 15 – 150)	0 – 40 (32 – 104)	0 – 40 (32 – 104)
	10	25	25	25	15	15
	IP67	IP67 / IP69K	IP66 / IP69K	IP45	IP44	IP44
	<ul style="list-style-type: none"> <li>• Electronic limit switches</li> <li>• Low level switching</li> <li>• Analog position feedback</li> <li>• Digital position feedback</li> </ul>	<ul style="list-style-type: none"> <li>• End-of-stroke output</li> <li>• Analog position feedback</li> <li>• Digital position feedback</li> <li>• Low-level switching</li> <li>• Synchronization</li> <li>• CAN bus J1939</li> </ul>	<ul style="list-style-type: none"> <li>• Analog position feedback</li> </ul>	<ul style="list-style-type: none"> <li>• Analog position feedback</li> </ul>	-	-
	114	124	136	142	148	154

**Do you want help to size and select the best match for your application?  
LinearMotioneering will guide you through the whole process!  
[www.linearactuators.linearmotioneering.com](http://www.linearactuators.linearmotioneering.com)**

# Electrak® HD – Technical Features



## Standard Features

- Onboard electronics with many optional functions
- Static load up to 18 kN (4050 lbf)
- Dynamic load up to 16 kN (3584 lbf)
- Stroke up to 1000 mm
- Speed up to 71 mm/s (2.8 in/s)
- Protection class static IP67 / IP69K and dynamic IP66 and tested for 500 hour salt spray resistance

## General Specifications

Screw type	ball
Nut type	load lock ball nut
Manual override	yes
Anti-rotation	yes
Static load holding brake	yes
Safety features	Electrak monitoring package: current monitoring voltage monitoring temperature monitoring load trip point calibration internal end-of-stroke limit switches <sup>(1)</sup> end-of-stroke dynamic braking
Electrical connections <sup>(2)</sup>	cable(s) with flying leads
Compliances	CE

(1) Dynamic braking is included at the ends of stroke for all Electrak HD actuators. Dynamic braking offered throughout the entire stroke length only on low-level switching and J1939 options.

(2) There are one or two cables depending on the control option used. The cable(s) enters the actuator via a connector. The replacement of an actuator can be completed by unplugging the old actuator and plugging in the new one.

## Optional Mechanical Features

- Variety of front and rear adapters
- Alternative adapter orientation

## Optional Electronic Control Features

- J1939 CAN bus
- Synchronization option
- Low-level switching
- End-of-stroke indication output
- Analog position output
- Digital position output

## Control Option Combinations

EXX	Electrak Monitoring Package only
ELX	EXX + End-of-Stroke Indication Output
EXP	EXX + Analog Position Output
EXD	EXX + Digital Position Output
ELP	ELX + Analog Position Output
ELD	ELX + Digital Position Output
LXX	EXX + Low-Level Signal Motor Switching
LLX	EXX + LXX + End-of-Stroke Indication Output
LXP	EXX + LXX + Analog Position Output
CNO	J1939 CAN Bus Control + Open-Loop Speed Control
SYN	Synchronization Option

## Accessories

- Rod end front adapter
- External slot-mounted limit switches

## Compatible Controls

Contact customer support at [www.thomsonlinear.com/cs](http://www.thomsonlinear.com/cs)

# Electrak HD – Technical Specifications

Mechanical Specifications		
Max. static load <sup>(1)</sup>	[kN (lbf)]	18 (4050)
Max. dynamic load (Fx)	[kN (lbf)]	
HDxx-B017		1.7 (382)
HDxx-B026		2.6 (585)
HDxx-B045		4.5 (1012)
HDxx-B068		6.8 (1529)
HDxx-B100		10 (2248)
HDxx-B160		16 (3584)
Speed @ no load/max. load <sup>(2)</sup>	[mm/s (in/s)]	
HDxx-B017		71/58 (2.8/2.28)
HDxx-B026		40/32 (1.6/1.3)
HDxx-B045		24/19 (0.94/0.75)
HDxx-B068		18/14 (0.71/0.55)
HDxx-B100		11/9 (0.43/0.35)
HDxx-B160		7/5 (0.27/0.21)
Min. ordering stroke (S) length	[mm]	50
Max. ordering stroke (S) length <sup>(3)</sup>	[mm]	1000
Ordering stroke length increments	[mm]	50
Operating temperature limits	[°C (F)]	-40 – 85 (- 40 – 185)
Full load duty cycle @ 25 °C (77 °F)	[%]	25 <sup>(4)</sup>
End play, maximum	[mm (in)]	1.2 (0.047)
Restraining torque	[Nm (lbf-in)]	0
Protection class - static		IP67, IP69K
Protection class - dynamic		IP66
Salt spray resistance	[h]	500

- (1) Max. static load at fully retracted stroke.
- (2) For units with the synchronization option, the speed is 25% lower at any load.
- (3) 500 mm max. for 16 kN
- (4) For HDxx-B100 and HDxx-160, unidirectional load, the duty cycle is 15%.
- (5) Do not use PWM voltage for speed control to avoid damaging the onboard electronics

Electrical Specifications		
Available input voltages <sup>(5)</sup>	[Vdc]	12, 24
Input voltage tolerance	[Vdc]	
HD12 (12 Vdc input voltage)		9 - 16
HD24 (24 Vdc input voltage)		18 - 32
Current draw @ no load/max. load	[A]	
HD12-B017		3/18
HD24-B017		1.5/9
HD12-B026		3/18
HD24-B026		1.5/9
HD12-B045		3/18
HD24-B045		1.5/9
HD12-B068		3/20
HD24-B068		1.5/10
HD12-B100		3/18
HD24-B100		1.5/9
HD12-B160		3/20
HD24-B160		1.5/10
Motor leads cross section	[mm <sup>2</sup> (AWG)]	2 (14)
Signal leads cross section	[mm <sup>2</sup> (AWG)]	0.5 (20)
Standard cable lengths (Ca1)	[m (in)]	0.3, 1.5, 5 (11.8, 59, 197)
Cable diameter (Ca2)	[mm (in)]	7.5 (.295)
Flying lead length (Ca3)	[mm (in)]	76 (3)
Stripped lead length (Ca4)	[mm (in)]	6 (0.25)

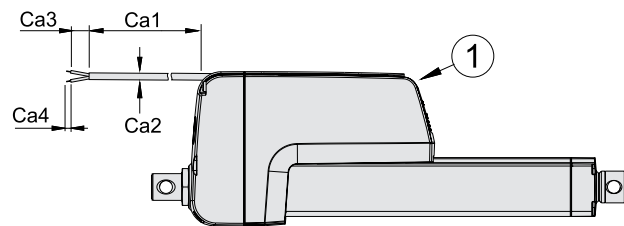

The drawing shows the cables exiting the cable slots at the end of the actuator housing, which is the shipping position. The user can adjust the exit point to be anywhere between the connector (1) in the front of the housing and the end of the cable slots.

Actuator Weight [kg]	Ordering stroke (S) [mm]																			
	50	100	150	200	250	300	350	400	450	500	550	600	650	700	750	800	850	900	950	1000
1.7 (382)	6.4	6.5	6.7	7.0	7.2	7.5	7.7	8.0	8.2	8.5	8.7	9.0	9.2	9.5	9.7	10.0	10.2	10.5	10.7	11.0
2.6 (585)	6.4	6.5	6.7	7.0	7.2	7.5	7.7	8.0	8.2	8.5	8.7	9.0	9.2	9.5	9.7	10.0	10.2	10.5	11.9	12.2
4.5 (1012)	6.4	6.5	6.7	7.0	7.2	7.5	7.7	8.0	8.2	8.5	8.7	9.0	9.2	9.5	10.7	11.0	11.3	11.6	11.9	12.2
6.8 (1592)	6.4	6.5	6.7	7.0	7.2	7.5	7.7	8.0	8.2	8.5	8.7	9.0	10.1	10.4	10.7	11.0	11.3	11.6	11.9	12.2
10 (2248)	6.6	6.7	7.0	7.2	7.5	7.7	8.0	8.2	9.1	9.4	9.7	10.0	10.3	10.6	10.9	11.2	11.5	11.8	12.1	12.4
16 (3584)	6.9	7.0	7.3	7.5	7.8	8.0	8.3	8.5	9.1	9.4	-	-	-	-	-	-	-	-	-	-

Conversion Factors: Millimeter to inch: 1 mm = 0.03937 in, kilogram to pound: 1 kg = 2.204623 lbf

# Electrak® HD – Dimensions

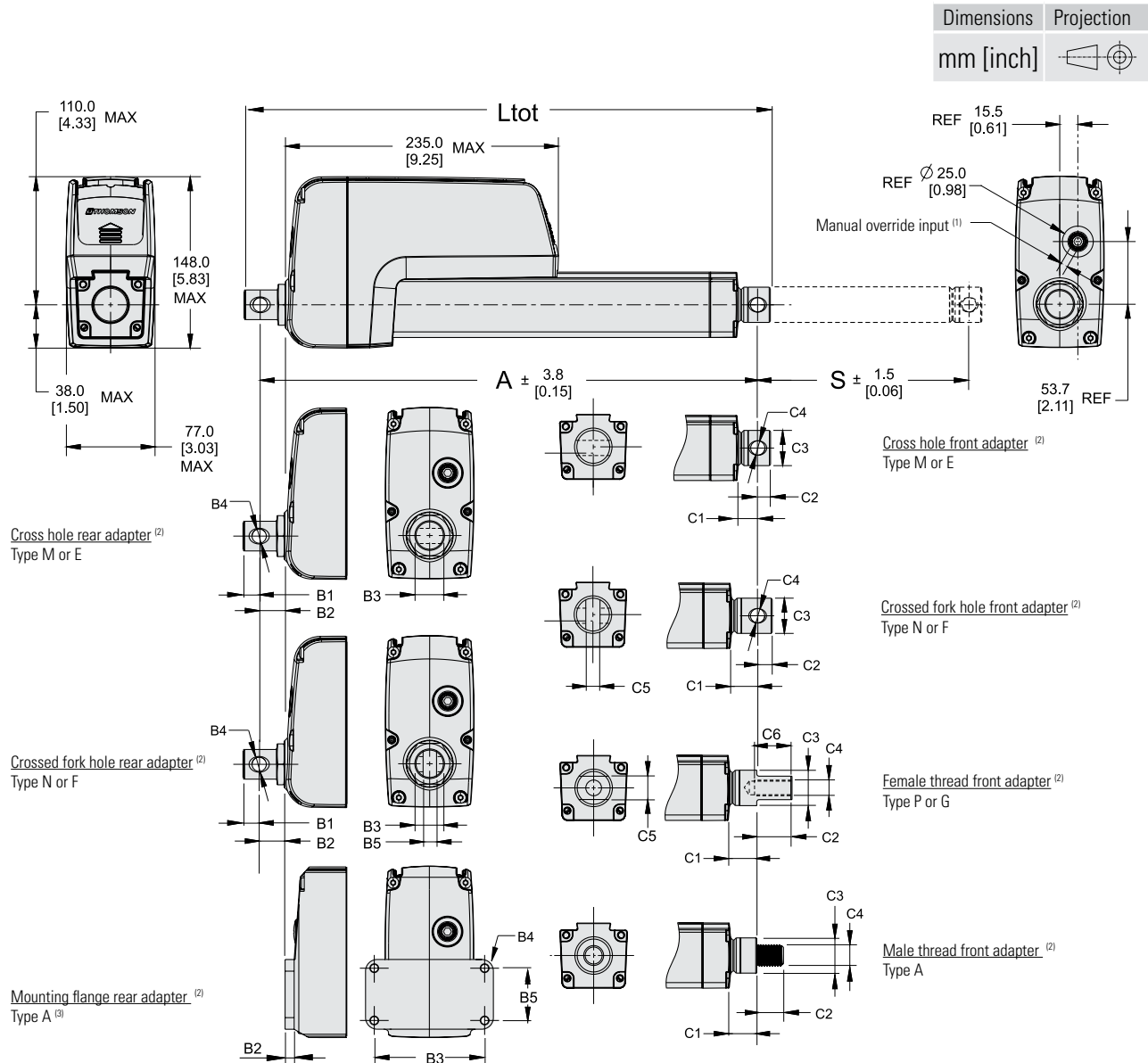

Rear and Front Adapter Dimensions [mm]

	Rear Adapter Types						Front Adapter Types						
	M	E	N	F	A <sup>(3)</sup>		M	E	N	F	P	G	A
B1	13.4	13.4	13.4	13.4	-	C1	see table on next page						16.5
B2	21.6	21.6	21.6	21.6	7.8	C2	10.9	10.9	12.9	12.9	30.0	30.0	20.0
B3	25.4	25.4	25.4	25.4	95.0	C3	see table on next page						
B4	12.2	12.8	12.2	12.8	6.6	C4	12.2	12.8	12.2	12.8	M12 × 1.75	1/2-20 UNF-2B	M16 × 2
B5	-	-	8.2	8.2	45.0	C5	-	-	8.2	8.2	19.0	19.0	-
						C6	-	-	-	-	35.0	35.0	-

(1) The input hole is covered with a plastic threaded plug. When removed, a 6 mm socket can be inserted and used as a crank.

(2) All adapters shown in the standard orientation.

(3) Rear mounting flange type A cannot be ordered with a higher maximum static load capacity than 10 kN or/and a maximum stroke of 300 mm.

# Electrak® HD – Dimensions

Maximum Dynamic Load and Stroke Relationships							
Maximum Dynamic Load (Fx) - kN (lbf.)	Total Length (Ltot), Retracted Length (A) and Front Adapter Dimensions [mm]	Ordering Stroke (S) [mm]					
		50 – 500 <sup>(1)</sup>	550 – 600	650 – 700	750 – 900	950 – 1000	
1.7 (382)	Ltot	A + B1 + C2					
	A	S + 150.9 + B2 + C1					
	C1	Type M, E	17.5				
		Type N, F	26.5				
		Type P, G	23.9				
C3	30.2						
2.6 (585)	Ltot	A + B1 + C2			A + B1 + C2		
	A	S + 150.9 + B2 + C1			S + 156.8 + B2 + C1		
	C1	Type M, E	17.5			24.0	
		Type N, F	26.5			27.0	
		Type P, G	23.9			24.9	
C3	30.2			35.0			
4.5 (1012)	Ltot	A + B1 + C2			A + B1 + C2		
	A	S + 150.9 + B2 + C1			S + 156.8 + B2 + C1		
	C1	Type M, E	17.5			24.0	
		Type N, F	26.5			27.0	
		Type P, G	23.9			24.9	
C3	30.2			35.0			
6.8 (1529)	Ltot	A + B1 + C2			A + B1 + C2		
	A	S + 150.9 + B2 + C1			S + 156.8 + B2 + C1		
	C1	Type M, E	17.5			24.0	
		Type N, F	26.5			27.0	
		Type P, G	23.9			24.9	
C3	30.2			35.0			
10 (2248)	Ltot	A + B1 + C2		A + B1 + C2			
	A	S + 180.9 + B2 + C1		S + 182 + B2 + C1			
	C1	Type M, E	17.5		24.0		
		Type N, F	26.5		27.0		
		Type P, G	23.9		24.9		
C3	30.2		35.0				
16 (3584)	Ltot	A + B1 + C2		strokes not available for this model			
	A	S + 182 + B2 + C1					
	C1	Type M, E	24.0				
		Type N, F	27.0				
		Type P, G	24.9				
C3	35.0						

(1) For a unit with 50 mm stroke, A and Ltot dimension are the same as for a unit with 100 mm stroke.

# Electrak® HD – Performance Diagrams

Load vs. Speed <sup>(1)</sup>

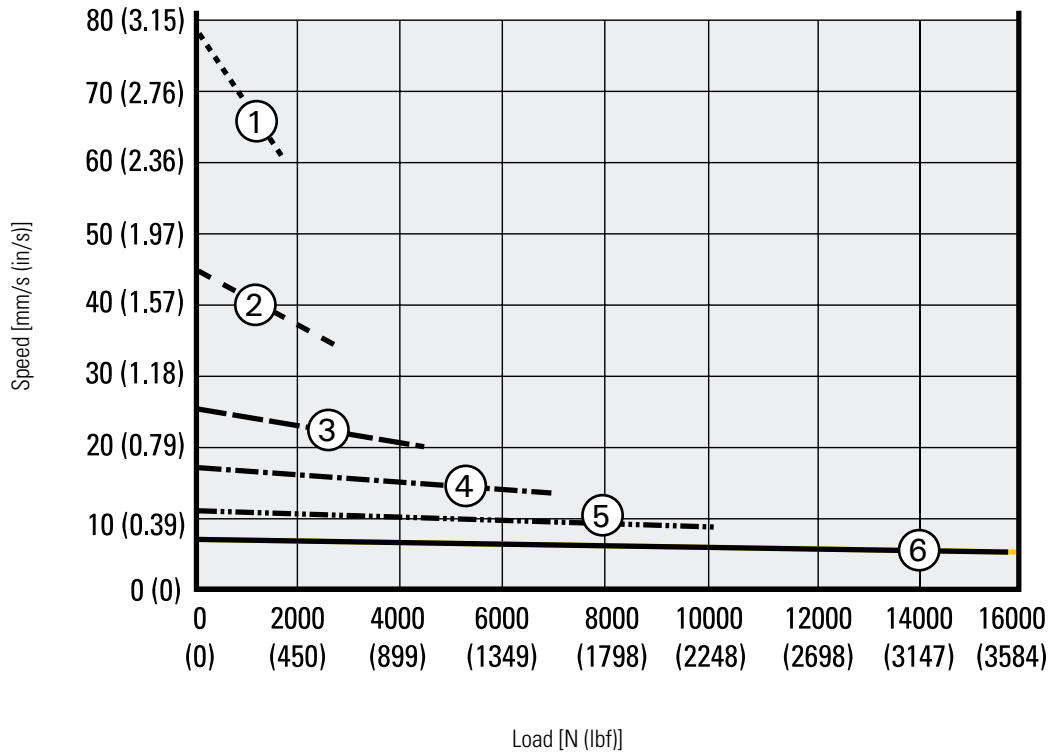

- |                                |         |                                 |             |                                |       |
|--------------------------------|---------|---------------------------------|-------------|--------------------------------|-------|
| 1. HDxxB017 (1.7 kN (382 lbf)) | .....   | 3. HDxxB045 (4.5 kN (1012 lbf)) | -----       | 5. HDxxB100 (10 kN (2248 lbf)) | ..... |
| 2. HDxxB026 (2.6 kN (585 lbf)) | - - - - | 4. HDxxB068 (6.8 kN (1529 lbf)) | - . - . - . | 6. HDxxB160 (16 kN (3584 lbf)) | ————— |

<sup>1</sup> Curves valid for all units except those with the synchronization option, where the speed at any load is 25% lower than for those without.

**Note!** Curves were generated at an ambient temperature of 21°C (70°F). Different ambient temperature and individual actuator characteristics can produce slightly different values.





# Electrak® HD – Ordering Key

## Ordering Key

1	2	3	4	5	6	7	8	9
<b>HD12</b>	<b>B026-</b>	<b>0300</b>	<b>LXX</b>	<b>2</b>	<b>M</b>	<b>M</b>	<b>S</b>	<b>D</b>

### 1. Model and input voltage

HD12 = Electrak HD, 12 Vdc  
HD24 = Electrak HD, 24 Vdc

### 2. Screw type, dynamic load capacity

B017 = ball screw, 1.7 kN (382 lbf)  
B026 = ball screw, 2.6 kN (585 lbf)  
B045 = ball screw, 4.5 kN (1012 lbf)  
B068 = ball screw, 6.8 kN (1529 lbf)  
B100 = ball screw, 10 kN (2248 lbf)  
B160 = ball screw, 16 kN (3584 lbf)

### 3. Ordering stroke length <sup>(1) (2)</sup>

0050 = 50 mm <sup>(3)</sup>  
0100 = 100 mm  
0150 = 150 mm  
0200 = 200 mm  
0250 = 250 mm  
0300 = 300 mm  
0350 = 350 mm  
0400 = 400 mm  
0450 = 450 mm  
0500 = 500 mm  
0550 = 550 mm  
0600 = 600 mm  
0650 = 650 mm  
0700 = 700 mm  
0750 = 750 mm  
0800 = 800 mm  
0850 = 850 mm  
0900 = 900 mm  
0950 = 950 mm  
1000 = 1000 mm

### 4. Electrak Modular Control System options

EXX = Electronic Monitoring Package only  
ELX = EXX + end-of-stroke indication output  
EXP = EXX + analog (potentiometer) position output  
EXD = EXX + digital position output  
ELP = ELX + analog (potentiometer) position output  
ELD = ELX + digital position output  
LXX = EXX + low-level signal motor switching  
LLX = EXX + LXX + end-of-stroke indication output  
LXP = EXX + LXX + analog (potentiometer) position output  
CNO = J1939 CAN bus + open-loop speed control  
SYN = LXX + synchronization option

### 5. Cable length

1 = 0.3 m long cables  
2 = 1.5 m long cables  
3 = 5.0 m long cables

### 6. Rear adapter/mounting flange options

A = rear mounting flange <sup>(4) (5)</sup>  
M = cross hole for 12 mm pin  
E = cross hole for ½ inch pin  
N = forked cross hole for 12 mm pin  
F = forked cross hole for ½ inch pin

### 7. Front adapter options

A = metric M16 male thread  
M = cross hole for 12 mm pin  
E = cross hole for ½ inch pin  
N = forked cross hole for 12 mm pin  
F = forked cross hole for ½ inch pin  
P = metric M12 female thread  
G = inch 1/2-20 UNF-2B female thread

### 8. Adapter orientation

S = standard  
M = 90 ° turned

### 9. Connection options

D = flying leads

(1) Other stroke lengths available upon request. Please contact customer support.

(2) 500 mm is the max. stroke length for 16 kN units.

(3) 50 mm stroke units will have same retracted length and envelope size as a 100 mm unit.

(4) Max. ordering stroke for the rear mounting flange type A is 300 mm.

(5) Max. dynamic load capacity for the rear mounting flange type A is 10 kN.

# Electrak<sup>®</sup> HD – Electrical Connections

## Option Type EXX

Actuator supply voltage	[Vdc]	
HD12		9 - 16
HD24		18 - 32

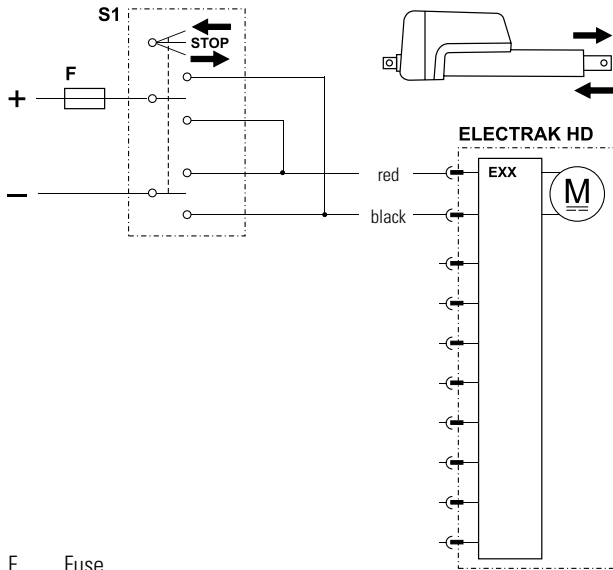

F Fuse  
S1 Double pole double throw switch

Control option EXX contains Electrak Monitoring Package features, guaranteeing safe operation of the actuator and equipment. With control option EXX, the polarity of the motor voltage is switched by a customer-supplied switch (switch, relay, etc.) to make the actuator extend or retract. The switch, power supply, wiring and all other components must be able to handle the motor current for the actuator model and load being used, as well as the inrush current (up to three times the max. continuous current for the max. load being used for up to 150 milliseconds).

## Option Type ELX

Actuator supply voltage	[Vdc]	
HD12		9 - 16
HD24		18 - 32

Output contact type	potential free	
Limit switch max. switch voltage	[Vdc]	140
Limit switch max. switch current	[mA]	350
Limit switch max. switch power	[W]	5

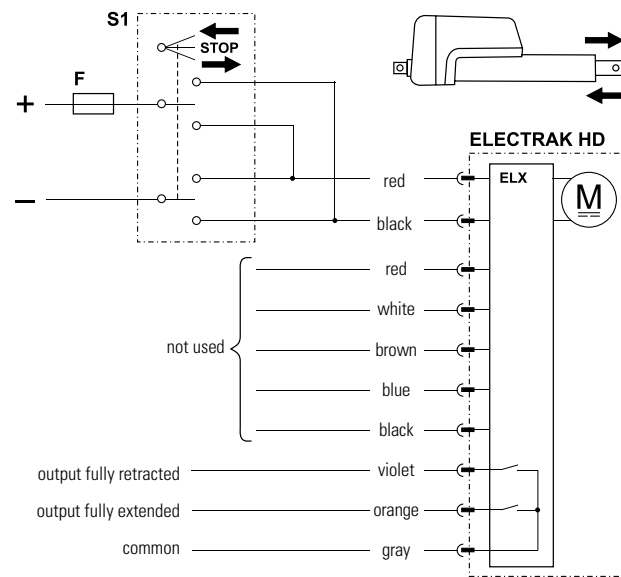

F Fuse  
S1 Double pole double throw switch

Control option ELX works as option EXX but also has two outputs that indicate when the extension tube is in its fully extended or retracted position.

# Electrak® HD – Electrical Connections

Option Type EXP		
Actuator supply voltage	[Vdc]	
HD12		9 - 16
HD24		18 - 32
Potentiometer type		wire-wound
Potentiometer max. input voltage	[Vdc]	32
Potentiometer max. power	[W]	1
Potentiometer linearity	[%]	± 0.25
Potentiometer output resolution	[ohm/mm]	
50 - 100 mm stroke		65.6
150 - 250 mm stroke		32.8
300 - 500 mm stroke		19.7
550 - 1000 mm stroke		9.8

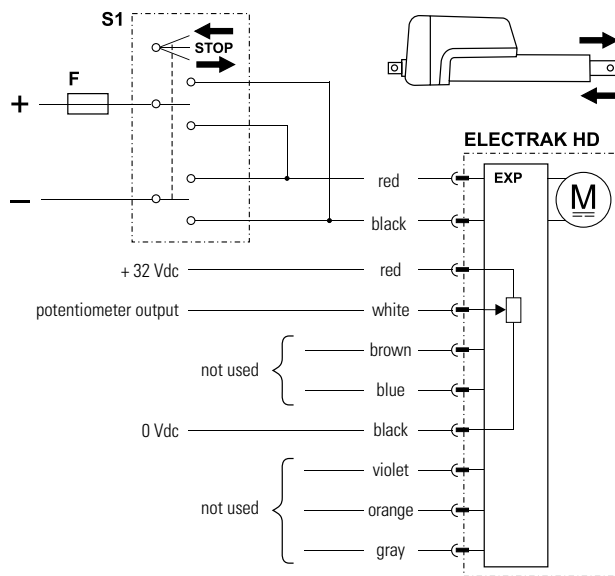

F Fuse  
S1 Double pole double throw switch

Control option EXP works as option EXX but also has an analog (potentiometer) output that will provide feedback on the extension tube position.

Option Type EXD		
Actuator supply voltage	[Vdc]	
HD12		9 - 16
HD24		18 - 32
Encoder type		hall effect
Encoder input voltage	[Vdc]	4 - 24
Encoder output voltage levels	[Vdc]	
low (logical zero), typical / max.		0.1 / 0.25
Encoder resolution	[mm/pulse]	
HDxx-B017		0.28
HDxx-B026		0.15
HDxx-B045		0.09
HDxx-B068		0.07
HDxx-B100		0.04
HDxx-B160		0.03

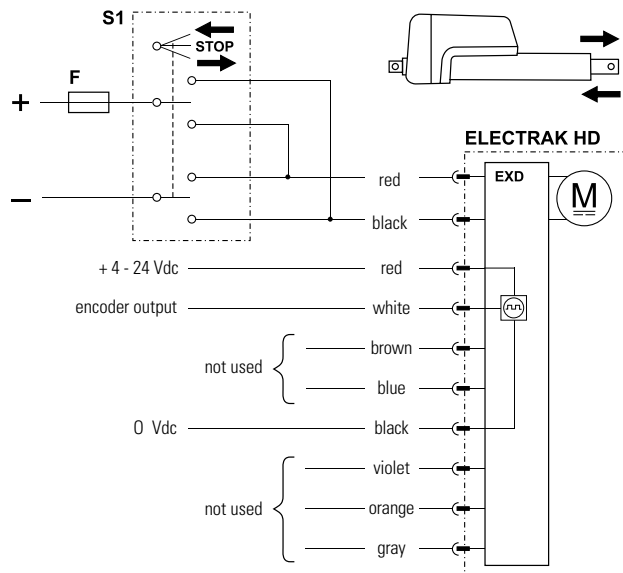

F Fuse  
S1 Double pole double throw switch

Control option EXD works as option EXX but also has a single-channel encoder output that will provide feedback on the extension tube position.

# Electrak<sup>®</sup> HD – Electrical Connections

Option Type ELP		
Actuator supply voltage	[Vdc]	9 - 16 18 - 32
Output contact type		potential free
Max. output voltage	[Vdc]	140
Max. output current	[mA]	350
Max. output power	[W]	5
Potentiometer type		wire-wound
Potentiometer max. input voltage	[Vdc]	32
Potentiometer max. power	[W]	1
Potentiometer linearity	[%]	± 0.25
Potentiometer output resolution	[ohm/mm]	
50 - 100 mm stroke		65.6
150 - 250 mm stroke		32.8
300 - 500 mm stroke		19.7
550 - 1000 mm stroke		9.8

Option Type ELD		
Actuator supply voltage	[Vdc]	9 - 16 18 - 32
Output contact type		potential free
Max. output voltage	[Vdc]	140
Max. output current	[mA]	350
Max. output power	[W]	5
Encoder type		hall effect
Encoder input voltage	[Vdc]	4 - 24
Encoder output voltage levels	[Vdc]	
low (logical zero), typical / max.		0.1 / 0.25
Encoder resolution	[mm/pulse]	
HDxx-B017		0.28
HDxx-B026		0.15
HDxx-B045		0.09
HDxx-B068		0.07
HDxx-B100		0.04
HDxx-B160		0.03

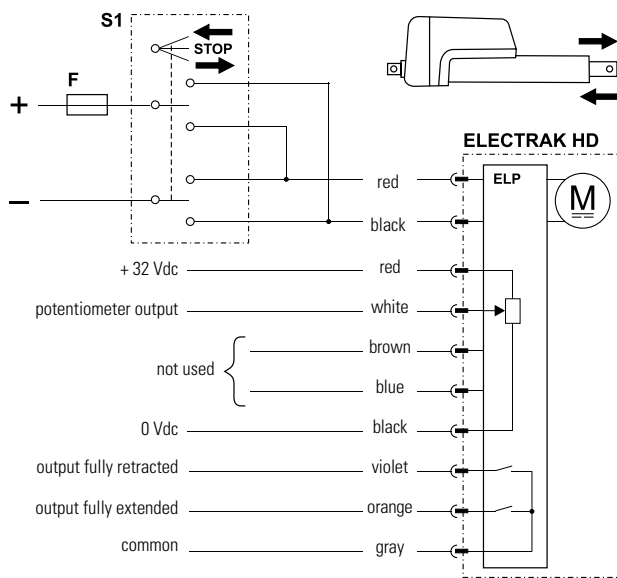

F Fuse  
S1 Double pole double throw switch

Control option ELP works as option EXP but also has two outputs that indicate when the extension tube is in its fully extended or retracted position.

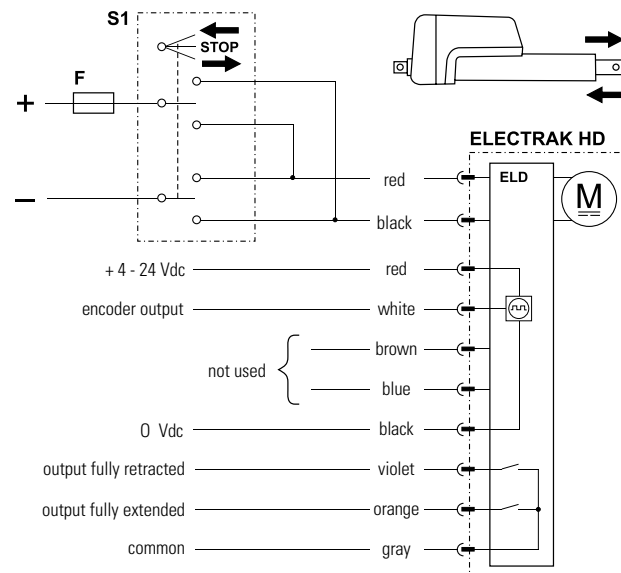

F Fuse  
S1 Double pole double throw switch

Control option ELD works as option EXD but also has two outputs that indicate when the extension tube is in its fully extended or retracted position.

# Electrak® HD – Electrical Connections

## Option Type LXX

Actuator supply voltage	[Vdc]	
HD12		9 - 16
HD24		18 - 32
Extend / retract input voltage	[Vdc]	9 - 32
Extend / retract input current	[mA]	6 - 22

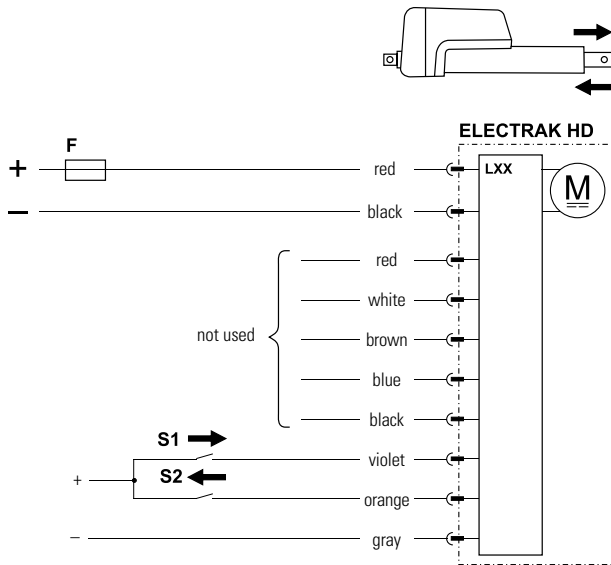

- F Fuse
- S1 Extend switch
- S2 Retract switch

Control option LXX has all the basic Electrak Monitoring Package features included in control option EXX, but the polarity of the motor voltage is switched by the onboard electronics instead. The customer-supplied switches used to command the actuator to extend or retract only need to handle low-level signals. However, the power supply and wiring that supply the actuator must be able to handle the motor current for the actuator model and load being used, as well as the inrush current (up to one and a half times the max. continuous current for the max. load being used for up to 150 milliseconds).

## Option Type LLX

Actuator supply voltage	[Vdc]	
HD12		9 - 16
HD24		18 - 32
Output contact type		potential free
Max. switched output voltage	[Vdc]	140
Max. output current	[mA]	350
Max. output power	[W]	5
Extend / retract input voltage	[Vdc]	9 - 32
Extend / retract input current	[mA]	6 - 22

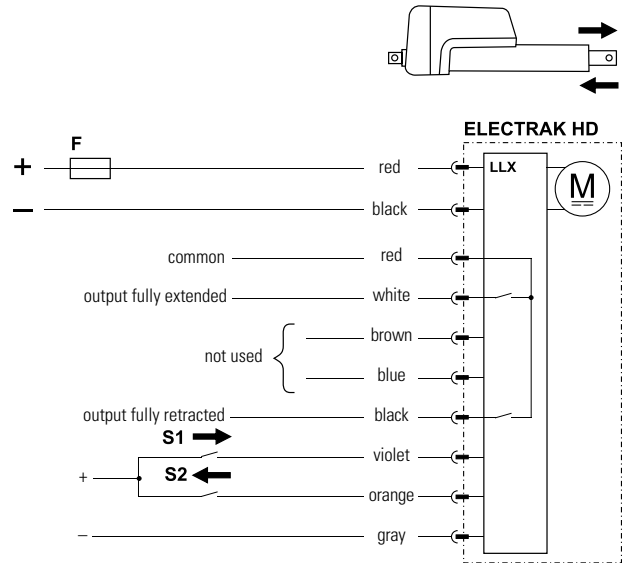

- F Fuse
- S1 Extend switch
- S2 Retract switch

Control option LLX works as option LXX but also has two outputs that indicate when the extension tube is in its fully extended or retracted position.

# Electrak<sup>®</sup> HD – Electrical Connections

Option Type LXP		
Actuator supply voltage	[Vdc]	9 - 16 HD12 HD24
Potentiometer type		wire-wound
Potentiometer max. input voltage	[Vdc]	32
Potentiometer max. power	[W]	1
Potentiometer linearity	[%]	± 0.25
Potentiometer output resolution	[ohm/mm]	65.6 50 - 100 mm stroke 32.8 150 - 250 mm stroke 19.7 300 - 500 mm stroke 9.8 550 - 1000 mm stroke
Extend / retract input voltage	[Vdc]	9 - 32
Extend / retract input current	[mA]	6 - 22

Option Type CNO		
Actuator supply voltage	[Vdc]	9 - 16 HD12 HD24
Command data includes:		<ul style="list-style-type: none"> <li>• position</li> <li>• speed</li> <li>• current</li> </ul>
Feedback data includes:		<ul style="list-style-type: none"> <li>• position</li> <li>• speed</li> <li>• current</li> <li>• other diagnostic information</li> </ul>

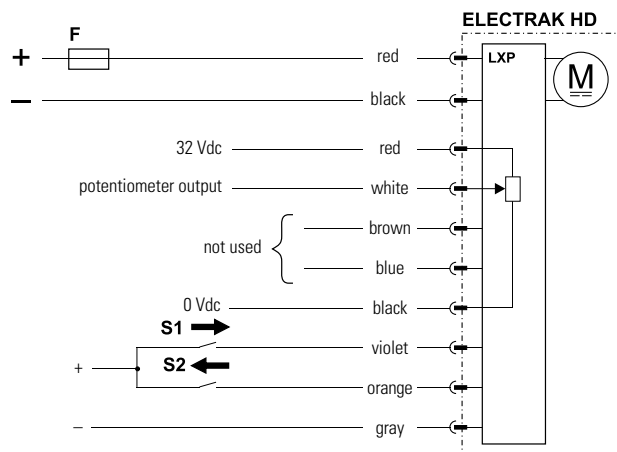
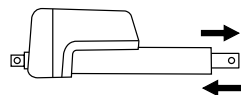
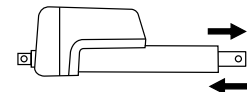

- F Fuse
- S1 Extend switch
- S2 Retract switch

Control option LXP works as option LXX but also has an analog (potentiometer) output that will provide feedback on the extension tube position.

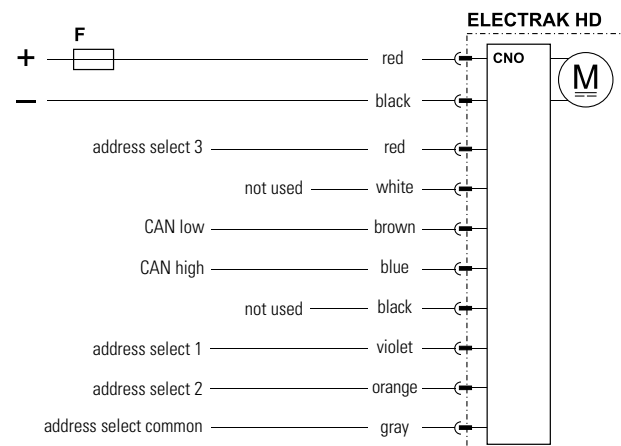

F Fuse

Control option CNO has a J1939 CAN bus control interface that controls and monitors the actuator. Extend and retract commands are sent via CAN messages on the CAN low and CAN high pins. Address select 1, 2 and 3 pins can be used as a BCD encoded address to the default address. This can be used when multiple J1939 actuators are located on a single bus.

# Electrak® HD – Electrical Connections

## Option Type SYN

Actuator supply voltage	[Vdc]	9 - 16 18 - 32
Extend / retract input voltage	[Vdc]	9 - 32
Extend / retract input current	[mA]	6 - 22
Number of synchronized actuators		2 - 4
Max. actuator speed difference	[%]	25

Control option SYN works as option LXX but also has a synchronization feature, allowing two or more actuators having the SYN option to run in integrated motion.

Uneven loading is acceptable as long as no individual actuator is loaded beyond its rated load.

When using the low-level extend and retract inputs on the master actuator, the slave(s) will follow. If there is a need to run an actuator individually, it is possible to put it into an override state by closing a switch (S3) connected to the red lead as shown in the wiring diagram.

Note: Ensure that supply voltage to each actuator is within  $\pm 1$  volt.

Note: For units with the synchronization option, the speed at a given load is 25% lower than for those without. This is true irrespective of the unit being in synchronization or override mode, or simply run individually.

Note: Only two resistors are needed. They act as terminating resistors for the communication leads. One will be on the first unit of the bus, the other will be on the last.

- F Fuses
- S1 Extend switch
- S2 Retract switch
- S3 Override switch
- R Resistors 120 Ohm

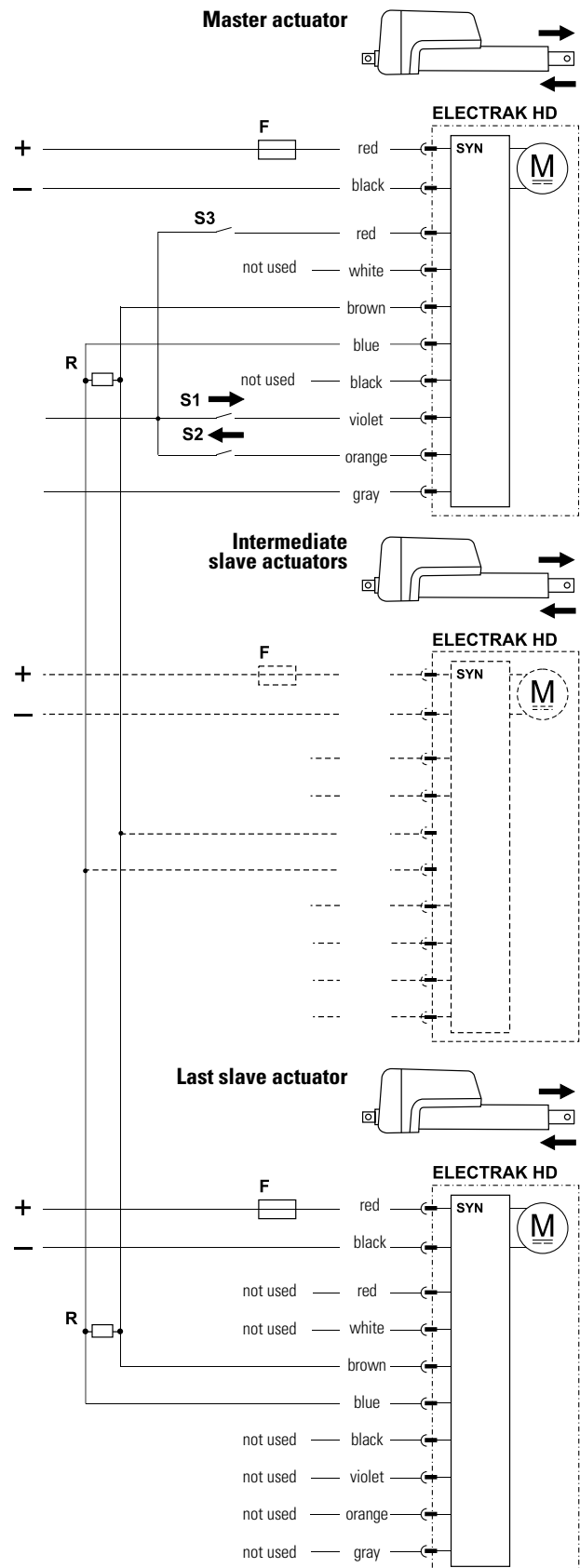



# Electrak<sup>®</sup> HD – Accessories

## Limit Switches for Cover Tube Mounting

Sensor type	solid state	reed switch
Contact type	normally open (N.O.)	
Output type	PNP	contact
Voltage [VDC/AC]	10 - 30 / -	5 -115 / 5 -115
Max. current [mA]	100	
Hysteresis [mm (in)]	1.5 (0.06)	1.0 (0.04)
Operating temperature [°C]	- 20 to + 70	- 20 to + 70
Lead cross section [mm <sup>2</sup> ]	3 × 0.14	2 × 0.14
Length (L) [mm (in)]	25.3 (1.0)	30.5 (1.2)
Protection class	IP69K	IP67
LED indicator	yes	
Connection	2 m cable with flying leads	
p/n	840-9131	840-9132

### Mounting positions

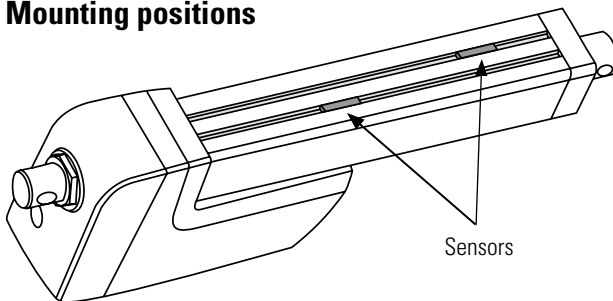

### Dimensions

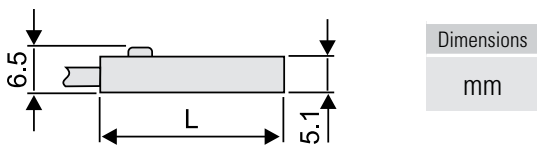

### Connection

Solid state

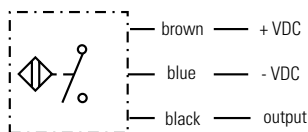

Reed switch

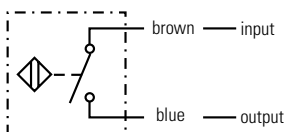

The limit switches are mounted in the cover tube slots and will be switched by a magnet mounted inside of the actuator on the extension tube.

## Rod End Front Adapter

Type	metric	inch
Material	Cadmium-plated steel	
Dimensions		
A	12.0 ± 0.1 mm	0.5 in
B	14.3 ± 0.1 mm	0.625 in
C	M12	1/2-20 UNF
p/n	756-9021	756-9007

### Dimensions

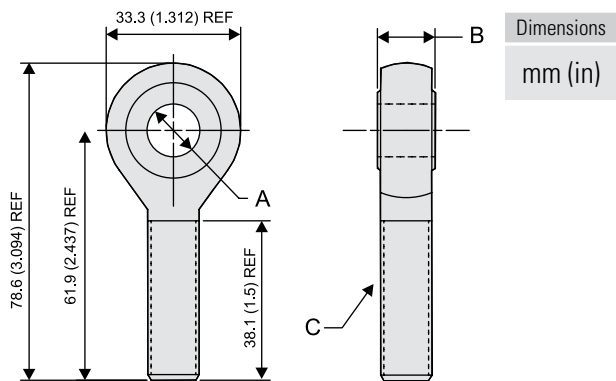

The rod end front adapter comes in one metric and one imperial version. The metric adapter can be mounted to the front of the extension tube if the actuator is equipped with the metric female thread front adapter option (type P), while the inch adapter requires the inch female thread option (type G).

## Wire Harness Kits

Part Number	Description
954-9364	0.3 m Power Only (EXX)
954-9365	1.5 m Power Only (EXX)
954-9366	5.0 m Power Only (EXX)
954-9367	0.3 m Power and 8-Wire Signal (ELX, ELP, ELD, LXX, LLX, LXP, CNO, SYN)
954-9368	1.5 m Power and 8-Wire Signal (ELX, ELP, ELD, LXX, LLX, LXP, CNO, SYN)
954-9369	5.0 m Power and 8-Wire Signal (ELX, ELP, ELD, LXX, LLX, LXP, CNO, SYN)
954-9370	0.3 m Power and 3-Wire Signal (EXP, EXD)
954-9471	1.5 m Power and 3-Wire Signal (EXP, EXD)
954-9372	5.0 m Power and 3-Wire Signal (EXP, EXD)

# Electrak® GX DC – Technical Features



## Standard Features

- Robust and reliable
- 12, 24, 36, 48 or 90 Vdc as standard input voltages
- Acme and ball screw models
- Static load up to 18 kN (4000 lbf)
- Dynamic load up to 9 kN (2000 lbf)
- Stroke up to 24 in
- Speed up to 61 mm/s (2.4 in/s)
- Protection class static IP66
- Overload clutch for mid and end of stroke protection
- Motor with thermal switch
- Maintenance free

## General Specifications

Screw type	acme or ball
Nut type Dxxx-xxA (acme screw) Dxxx-xxB (ball screw)	self locking lead nut load lock ball nut
Manual override	no (optional)
Anti-rotation	no
Static load holding brake acme screw models ball screw models	no (self locking) yes
Safety features	overload clutch motor auto reset thermal switch
Anti coast brake	yes
Electrical connections no potentiometer option with potentiometer option	flying leads with or without connector cable with or without connector
Compliances standard optional	— CE <sup>(1)(2)</sup>

(1) Actuators used in the EU must be in compliance with CE

(2) The 90 Vdc model cannot be delivered in compliance with CE.

## Optional Mechanical Features

Variety of front and rear adapters

Manual override

## Optional Electrical Features

Potentiometer feedback

## Accessories

Mechanical      Mounting pins

## Compatible Controls

Contact customer support at [www.thomsonlinear.com/cs](http://www.thomsonlinear.com/cs)

# Electrak<sup>®</sup> GX DC – Technical Specifications

Mechanical Specifications			Electrical Specifications		
Max. static load <sup>(1)</sup>	[N (lbf)]		Available input voltages <sup>(1)(2)</sup>	[Vdc]	12, 24, 36, 48, 90
Dxx-xxA (acme screw)		11350 (2500)	Input voltage tolerance	[%]	± 10
Dxx-xxB (ball screw)		18000 (4000)	Current draw @ no load/max. load	[A]	
Max. dynamic load (Fx)	[N (lbf)]		D12x-05A5		12.0/33.0
Dxxx-05A5		1100 (250)	D12x-10A5		8.0/27.0
Dxxx-10A5		2250 (500)	D12x-20A5		3.0/15.0
Dxxx-20A5		2250 (500)	D12x-05B5		8.0/28.0
Dxxx-05B5		2250 (500)	D12x-10B5		5.0/27.0
Dxxx-10B5		4500 (1000)	D12x-20B5		3.0/13.0
Dxxx-20B5		4500 (1000)	D12x-21B5		3.0/20.0
Dxxx-21B5		6800 (1500)	D12x-2KB5		4.0/25.0
Dxxx-2KB5		9000 (2000)	D24x-05A5		6.0/16.5
Speed @ no load/max. load	[mm/s (in/s)]		D24x-10A5		4.0/13.5
Dxxx-05A5		54/32 (2.10/1.20)	D24x-20A5		1.5/7.5
Dxxx-10A5		30/18 (1.20/0.70)	D24x-05B5		4.0/14.0
Dxxx-20A5		15/12 (0.67/0.45)	D24x-10B5		2.5/13.5
Dxxx-05B5		61/37 (2.40/1.40)	D24x-20B5		1.5/7.5
Dxxx-10B5		30/19 (1.30/0.80)	D24x-21B5		1.5/10.0
Dxxx-20B5		15/12 (0.60/0.45)	D24x-2KB5		2.0/12.5
Dxxx-21B5		15/11 (0.60/0.43)	D36x-05A5		4.0/11.0
Dxxx-2KB5		15/9 (0.60/0.40)	D36x-10A5		2.67/9.0
Min. ordering stroke (S) length	[in]	2	D36x-20A5		1.0/5.1
Max. ordering stroke (S) length <sup>(2)</sup>	[in]	24	D36x-05B5		2.67/9.3
Ordering stroke length increments	[in]	2	D36x-10B5		1.67/9.0
Operating temperature limits	[°C (F)]	-25 – 65 (-15 – 150)	D36x-20B5		1.0/5.1
Full load duty cycle @ 25 °C (77 °F)	[%]	25	D36x-21B5		1.0/6.7
End play, maximum	[mm (in)]	1.0 (0.04)	D36x-2KB5		1.34/8.4
Restraining torque	[Nm (lbf-in)]	11.3 (100)	D48x-05A5		3.0/8.3
Protection class - static, standard (optional)		IP66 (IP69K)	D48x-10A5		2.0/6.8
Salt spray resistance	[h]	96	D48x-20A5		0.8/3.8
			D48x-05B5		2.0/7.0
			D48x-10B5		1.3/6.8
			D48x-20B5		0.8/3.8
			D48x-21B5		0.8/5.0
			D48x-2KB5		1.0/6.3
			D90x-05A5		1.5/4.1
			D90x-10A5		1.0/3.4
			D90x-20A5		0.4/1.9
			D90x-05B5		1.0/3.5
			D90x-10B5		0.6/3.4
			D90x-20B5		0.4/1.9
			D90x-21B5		0.4/2.5
			D90x-2KB5		0.5/3.2
			Flying leads length	[mm (in)]	165 (7.5)
			Flying leads diameter	[mm (in)]	3 (0.12)
			Flying leads cross section	[mm <sup>2</sup> (AWG)]	2 (14)
			Cable length with option pot.	[mm (in)]	600 (24)
			Cable diameter with option pot.	[mm (in)]	9 (0.35)
			Cable leads cross section with option potentiometer	[mm <sup>2</sup> (AWG)]	
			motor leads		2.5 (14)
			potentiometer leads		1.5 (16)

(1) Max. static load at fully retracted stroke

(2) Max. ordering stroke length for Dxx-2KB5 is 10 inches

(1) For other input voltages - contact customer support.

(2) 90 Vdc model not CE compliant.

# Electrak® GX DC – Dimensions

Dimensions	Projection
mm [inch]	

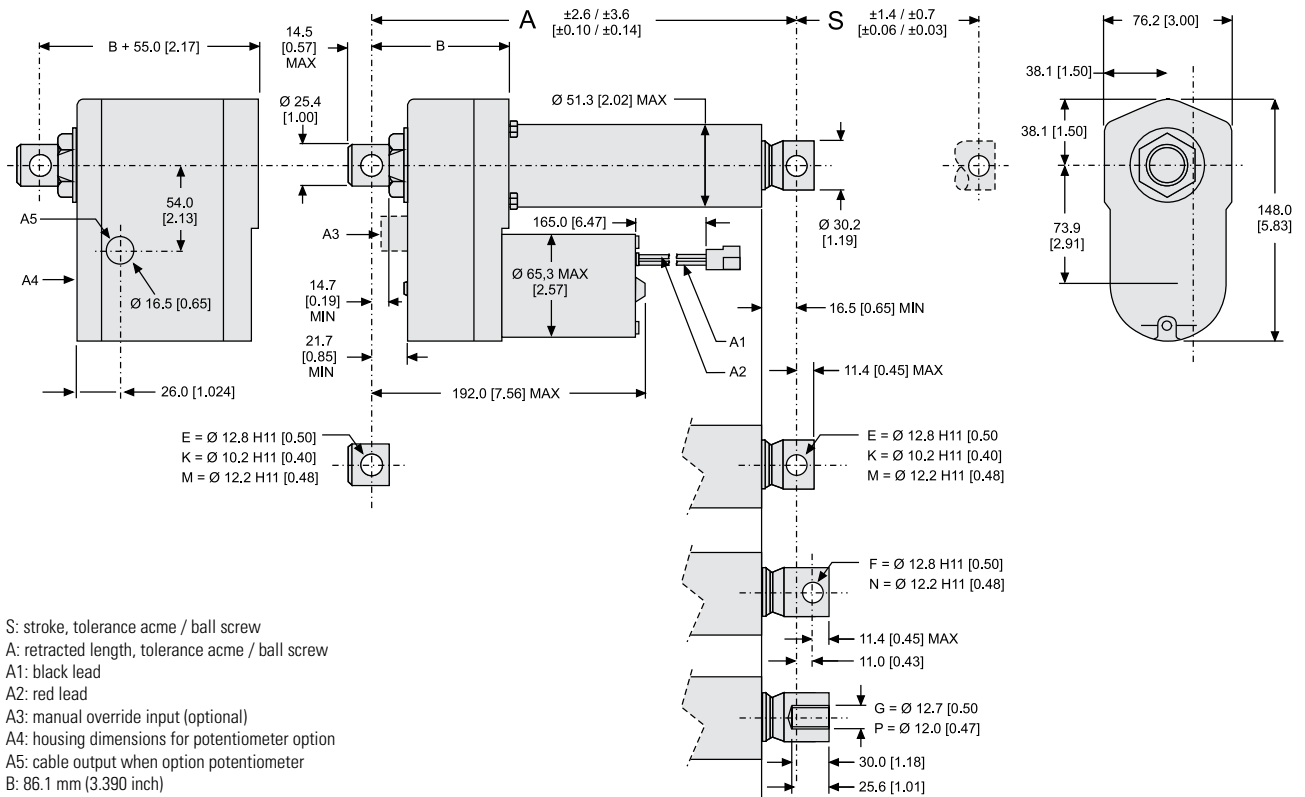

- S: stroke, tolerance acme / ball screw
- A: retracted length, tolerance acme / ball screw
- A1: black lead
- A2: red lead
- A3: manual override input (optional)
- A4: housing dimensions for potentiometer option
- A5: cable output when option potentiometer
- B: 86.1 mm (3.390 inch)

## Stroke, Retracted Length and Weight Relationships

Ordering stroke (S)	[in]	2	4	6	8	10	12	14	16	18	20	22	24
Retracted length, acme screw models (A)	[mm]	211.3	262.1	312.9	363.7	414.5	465.3	583.7	634.5	685.3	736.1	786.9	837.7
	[in]	8.32	10.32	12.32	14.32	16.32	18.32	22.98	24.98	26.98	28.98	30.98	32.98
Retracted length, ball screw models (A)	[mm]	251.5	302.3	353.1	403.9	454.7	505.5	623.6	674.4	725.2	776.0	826.8	877.6
	[in]	9.90	11.90	13.90	15.90	17.90	19.90	24.55	26.55	28.55	30.55	32.55	34.55
Add on length for option potentiometer	[mm]	55.0											
	[in]	2.17											
Weight, acme screw models	[kg]	4.4	4.6	4.8	5.0	5.1	5.3	5.5	5.6	5.8	5.9	6.1	6.2
	[lbf]	9.7	10.1	10.6	11.0	11.2	11.7	12.1	12.3	12.8	13.0	13.4	13.6
Weight, ball screw models	[kg]	5.0	5.2	5.4	5.6	5.8	6.0	6.1	6.2	6.4	6.5	6.7	6.9
	[lbf]	11.0	11.4	11.9	12.3	12.8	13.2	13.4	13.6	14.1	14.3	14.7	15.2
Add on weight for option potentiometer	[kg]	1.30											
	[lbf]	2.86											

# Electrak® GX DC – Performance Diagrams

Load vs. Speed

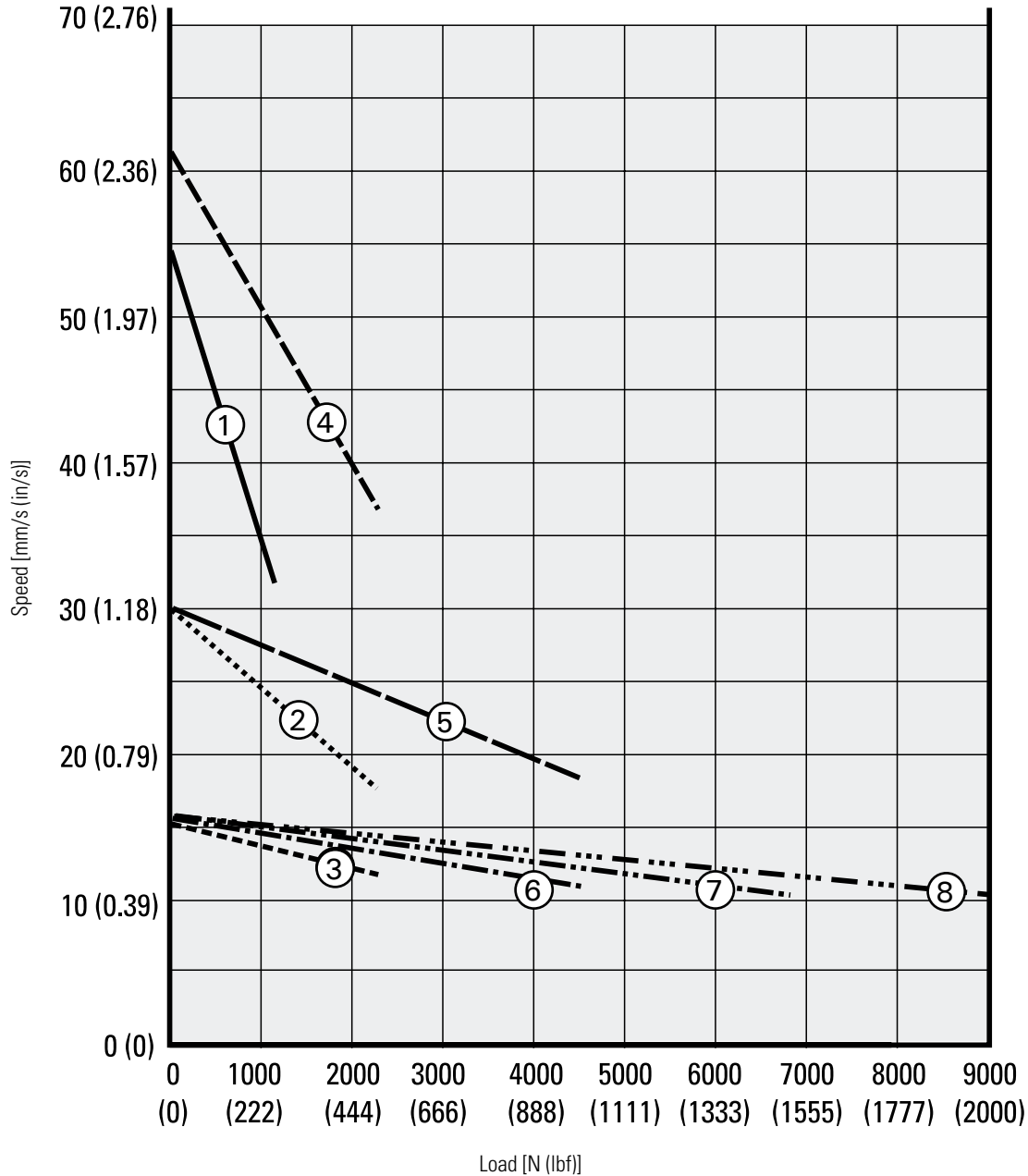

- |                                 |           |                                  |                     |
|---------------------------------|-----------|----------------------------------|---------------------|
| 1. Dxxx-05A5 (1100 N (250 lbf)) | —————     | 5. Dxxx-10B5 (4500 N (1000 lbf)) | —————               |
| 2. Dxxx-10A5 (2250 N (500 lbf)) | .....     | 6. Dxxx-20B5 (4500 N (1000 lbf)) | - . - . - . - . - . |
| 3. Dxxx-20A5 (2250 N (500 lbf)) | - - - - - | 7. Dxxx-21B5 (6800 N (1500 lbf)) | - . - . - . - . - . |
| 4. Dxxx-05B5 (2250 N (500 lbf)) | - - - - - | 8. Dxxx-2KB5 (9000 N (2000 lbf)) | - . . . - . . . - . |

# Electrak® GX DC – Performance Diagrams

Load vs. Current for 12 and 24 Vdc actuators

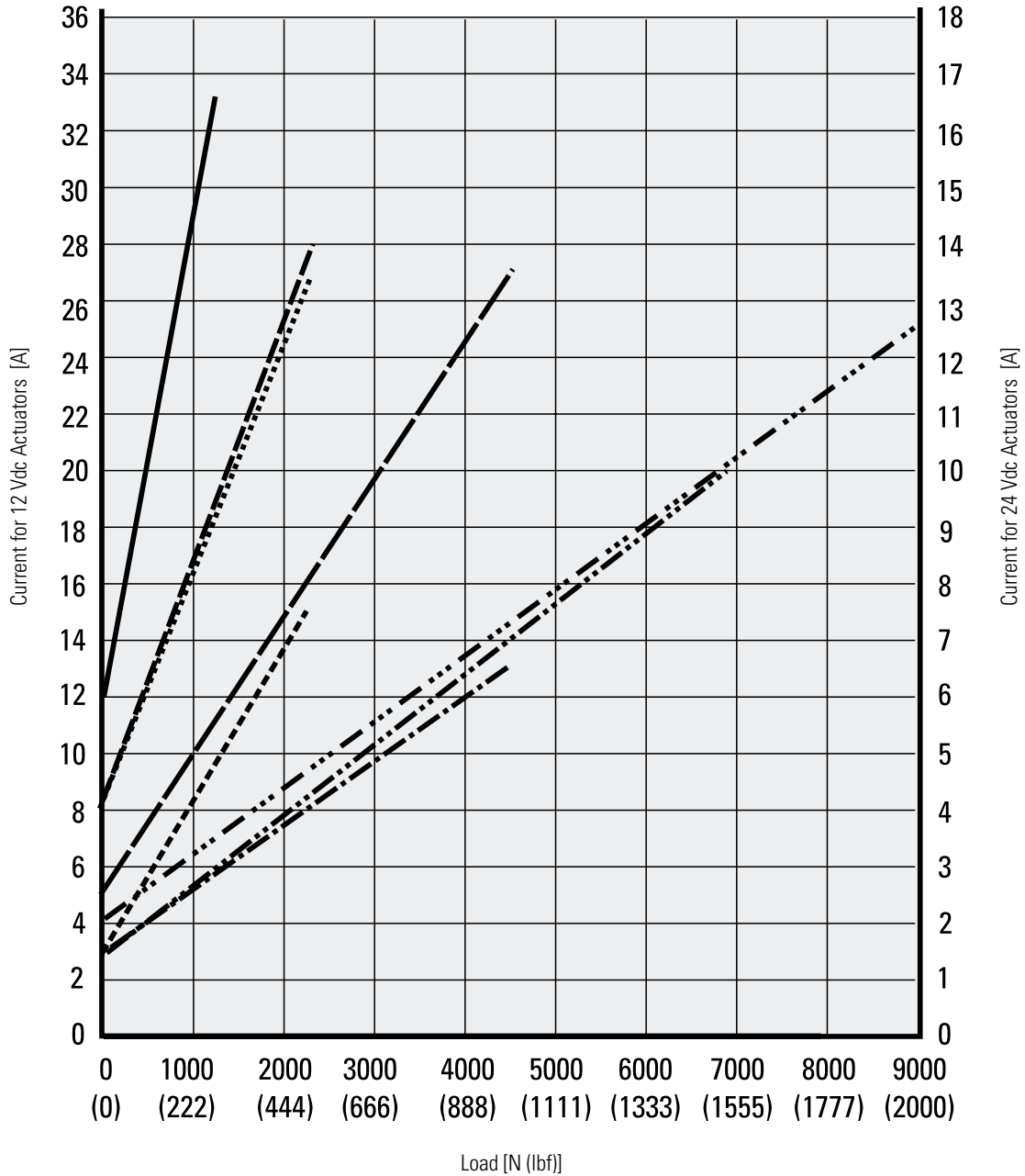

# Electrak® GX DC – Performance Diagrams

Load vs. Current for 36 and 48 Vdc actuators

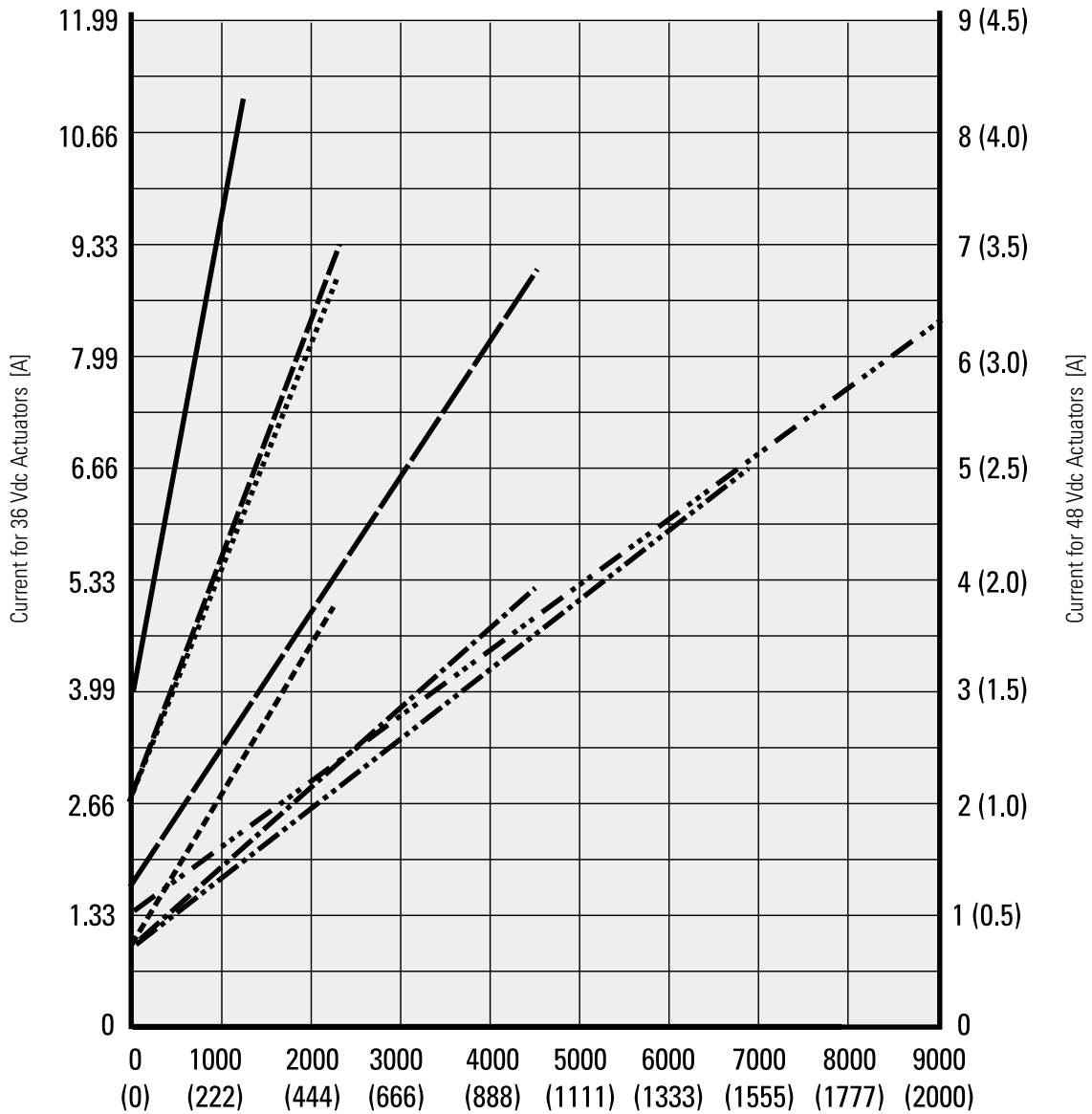

# Electrak® GX DC – Ordering Key

## Ordering Key

1	2	3	4	5	6	7	8	9
<b>D12C</b>	<b>05A5-</b>	<b>02</b>	<b>M0</b>	<b>N</b>	<b>N</b>	<b>D</b>	<b>E</b>	<b>E</b>

### 1. Model, input voltage and CE compliance

D12C = Electrak GX, 12 Vdc, CE compliant  
 D24C = Electrak GX, 24 Vdc, CE compliant  
 D36C = Electrak GX, 36 Vdc, CE compliant  
 D48C = Electrak GX, 48 Vdc, CE compliant  
 D12N = Electrak GX, 12 Vdc, not CE compliant  
 D24N = Electrak GX, 24 Vdc, not CE compliant  
 D36N = Electrak GX, 36 Vdc, not CE compliant  
 D48N = Electrak GX, 48 Vdc, not CE compliant  
 D90N = Electrak GX, 90 Vdc, not CE compliant

### 2. Dynamic load capacity, screw type and maximum speed

05A5 - = 1100 N, acme, 54 mm/s  
 10A5 - = 2250 N, acme, 30 mm/s  
 20A5 - = 2250 N, acme, 15 mm/s  
 05B5 - = 2250 N, ball, 61 mm/s  
 10B5 - = 4500 N, ball, 30 mm/s  
 20B5 - = 4500 N, ball, 15 mm/s  
 21B5 - = 6800 N, ball, 15 mm/s<sup>(1)</sup>  
 2KB5 - = 9000 N, ball, 9 mm/s<sup>(2)</sup>

### 3. Ordering stroke length

02 = 2 inch (50.8 mm)  
 04 = 4 inch (101.6 mm)  
 06 = 6 inch (152.4 mm)  
 08 = 8 inch (203.2 mm)  
 10 = 10 inch (254.0 mm)  
 12 = 12 inch (304.8 mm)  
 14 = 14 inch (355.6 mm)  
 16 = 16 inch (406.4 mm)  
 18 = 18 inch (457.2 mm)  
 20 = 20 inch (508.0 mm)  
 22 = 22 inch (558.8 mm)  
 24 = 24 inch (609.6 mm)

### 4. Rear adapter hole orientation

M0 = adaptor at 0° (standard)  
 M3 = adaptor at 90°<sup>(3)</sup>

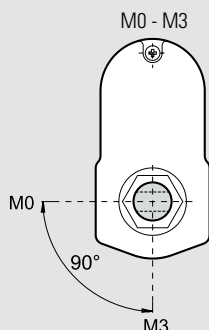

### 5. Ingress protection rating

N = IP66  
 K = IP69K

### 6. Options

N = no option  
 P = potentiometer feedback  
 H = manual override

Dimensions for manual override option

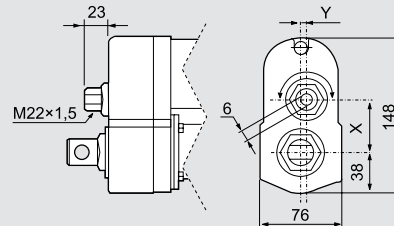

Model	X	Y
Dxxx05A(B)5-	49.6	0.0
Dxxx10A(B)5-	43.3	5.2
Dxxx20(21, 2K)A(B)5-	38.9	0.0

### 7. Connector option

A = AMP terminal 42098-2, house 180908-5  
 B = Packard Electric 56 Series  
 D = no connector (flying leads)

### 8. Front adapter option

E = cross hole for 0.5 inch pin  
 F = forked cross hole for 0.5 inch pin  
 G = 0.5 inch female thread  
 K = cross hole for 10 mm pin  
 M = cross hole for 12 mm pin  
 N = forked cross hole for 12 mm pin  
 P = 12 mm female thread

### 9. Rear adapter option

E = cross hole for 0.5 inch pin  
 K = cross hole for 10 mm pin  
 M = cross hole for 12 mm pin

(1) 21B5 not possible with strokes above 20 inch

(2) 2KB5 not possible for strokes above 12 inch

(3) Not possible with option manual override



# Electrak<sup>®</sup> GX DC – Electrical Connections

## Without Option

Actuator supply voltage	[Vdc]	
D12x		12
D24x		24
D36x		36
D48x		48
D90N		90

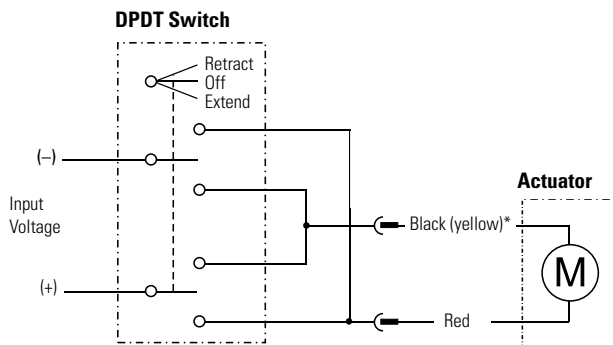

\* Lead can be black or yellow

Connect the red lead to positive and black (yellow)\* to negative to extend the actuator. Change polarity to retract the actuator.

## Option Potentiometer

Actuator supply voltage	[Vdc]	
D12x		12
D24x		24
D36x		36
D48x		48
D90N		90

Potentiometer type		wirewound
Potentiometer max. input voltage	[Vdc]	32
Potentiometer max. power	[W]	2
Potentiometer linearity	[%]	± 0.25
Potentiometer output resolution	[ohm/mm]	
2 - 10 inch stroke		39
11 - 20 inch stroke		20
21 - 24 inch stroke		10

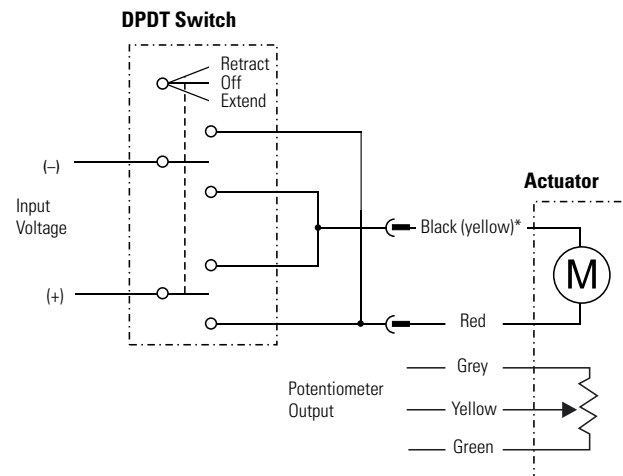

\* Lead can be black or yellow

Connect the red lead to positive and black (yellow)\* to negative to extend the actuator. Change polarity to retract the actuator. The potentiometer output cable has 0 ohm between grey and yellow leads when the actuator is fully extended.

# Electrak® GX DC – Accessories

## Mounting Pin Kits

Designation	A [mm(in)]	Part Number
Mounting pins (pair)	12.7 (0.5)	D603 028

The mounting pins are used in the rear and front adapter holes of the actuator. The pins have a groove in each end so that it can be secured with snap rings.

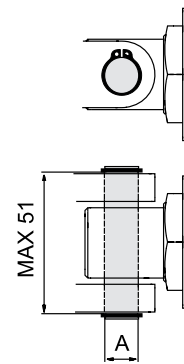

Dimensions

mm



# Electrak® GX AC – Technical Features



## Standard Features

- Robust and reliable
- 1 × 115, 1 × 230 or 3 × 400 Vac as standard input voltages
- Acme and ball screw models
- Static load up to 18 kN (4000 lbf)
- Dynamic load up to 9 kN (2000 lbf)
- Stroke up to 24 in
- Speed up to 61 mm/s (2.4 in/s)
- Protection class static IP45
- Overload clutch for mid and end of stroke protection
- Anti coast brake
- Motor with thermal switch
- Maintenance free

## General Specifications

Screw type	acme or ball
Nut type Axxx-xxA (acme screw) Axxx-xxB (ball screw)	self locking lead nut load lock ball nut
Manual override	no (optional)
Anti-rotation	no
Static load holding brake acme screw models ball screw models	no (self locking) yes
Safety features	overload clutch motor auto reset thermal switch
Anti coast brake	yes
Electrical connections no potentiometer option with potentiometer option	cable with flying leads 2 x cable with flying leads
Compliances standard optional	– CE <sup>(1)</sup>
Certificates	UL, CSA

(1) Actuators used in the EU must be in compliance with CE

## Optional Mechanical Features

Variety of front and rear adapters

Manual override

## Optional Electrical Features

Potentiometer feedback

# Electrak<sup>®</sup> GX AC – Technical Specifications

## Mechanical Specifications

Max. static load <sup>(1)</sup> Axx-xxA (acme screw) Axx-xxB (ball screw)	[N (lbf)]	11350 (2500) 18000 (4000)
Max. dynamic load (Fx) Axxx-05A5 <sup>(2)</sup> Axxx-10A5 Axxx-20A5 Axxx-05B5 Axxx-10B5 Axxx-20B5 Axxx-21B5 <sup>(2)</sup> Axxx-2KB5 <sup>(2)</sup>	[N (lbf)]	1100 (250) 2250 (500) 2250 (500) 2250 (500) 4500 (1000) 4500 (1000) 6800 (1500) 9000 (2000)
Speed @ no load/max. load Axxx-05A5 <sup>(2)</sup> Axxx-10A5 Axxx-20A5 Axxx-05B5 Axxx-10B5 Axxx-20B5 Axxx-21B5 <sup>(2)</sup> Axxx-2KB5 <sup>(2)</sup>	[mm/s (in/s)]	54/32 (2.10/1.20) 30/18 (1.20/0.70) 15/12 (0.67/0.45) 61/37 (2.40/1.40) 30/19 (1.30/0.80) 15/12 (0.60/0.45) 15/11 (0.60/0.43) 15/9 (0.60/0.40)
Min. ordering stroke (S) length	[in]	6
Max. ordering stroke (S) length <sup>(3)</sup>	[in]	24
Ordering stroke length increments	[in]	2
Operating temperature limits	[°C (F)]	-25 – 65 (-15 – 150)
Max. on time	[s]	45
Full load duty cycle @ 25 °C (77 °F)	[%]	25
End play, maximum	[mm (in)]	1.0 (0.04)
Restraining torque	[Nm (lbf-in)]	11.3 (300)
Protection class - static		IP45
Salt spray resistance	[h]	96

(1) Max. static load at fully retracted stroke

(2) Not possible with supply voltage 3 × 400 Vac

(3) 2KB5 not possible for strokes above 12 inch

## Electrical Specifications

Available input voltages <sup>(1)</sup>	[Vac]	1 × 115 <sup>(2)</sup> 1 × 230 <sup>(2)</sup> 3 × 400
Input voltage tolerance	[%]	± 10
Current draw @ no load/max. load A12x-05A5 A12x-10A5 A12x-20A5 A12x-05B5 A12x-10B5 A12x-20B5 A12x-21B5 A12x-2KB5 A22x-05A5 A22x-10A5 A22x-20A5 A22x-05B5 A22x-10B5 A22x-20B5 A22x-21B5 A22x-2KB5 A42x-05A5 A42x-10A5 A42x-20A5 A42x-05B5 A42x-10B5 A42x-20B5 A42x-21B5 A42x-2KB5	[A]	1.2/2.8 1.2/2.8 0.8/2.2 1.0/2.8 1.0/2.8 1.0/2.4 0.8/2.8 0.8/3.7 0.6/1.4 0.6/1.4 0.4/1.4 0.5/1.3 0.5/1.3 0.5/1.4 0.5/1.4 0.4/1.6 0.4/1.8 not possible 0.35/0.7 0.30/0.7 0.45/0.7 0.45/0.7 0.45/0.7 not possible not possible
Motor cable length	[mm (in)]	600 (24)
Motor cable diameter	[mm (in)]	10 (0.4)
Motor cable leads cross section	[mm <sup>2</sup> (AWG)]	1.5 (16)
Potentiometer cable length <sup>(3)</sup>	[mm (in)]	500 (20)
Potentiometer cable diameter <sup>(3)</sup>	[mm (in)]	9 (0.35)
Pot. cable leads cross section <sup>(3)</sup>	[mm <sup>2</sup> (AWG)]	1.5 (16)

(1) For other input voltages - contact customer support.

(2) Capacitor required to run the actuator.

1 × 115 Vac = 35 µF, p/n 9200-448-002

1 × 230 Vac = 10 µF, p/n 9200-448-003

(3) Potentiometer is optional

# Electrak® GX AC – Dimensions

Dimensions	Projection
mm [inch]	

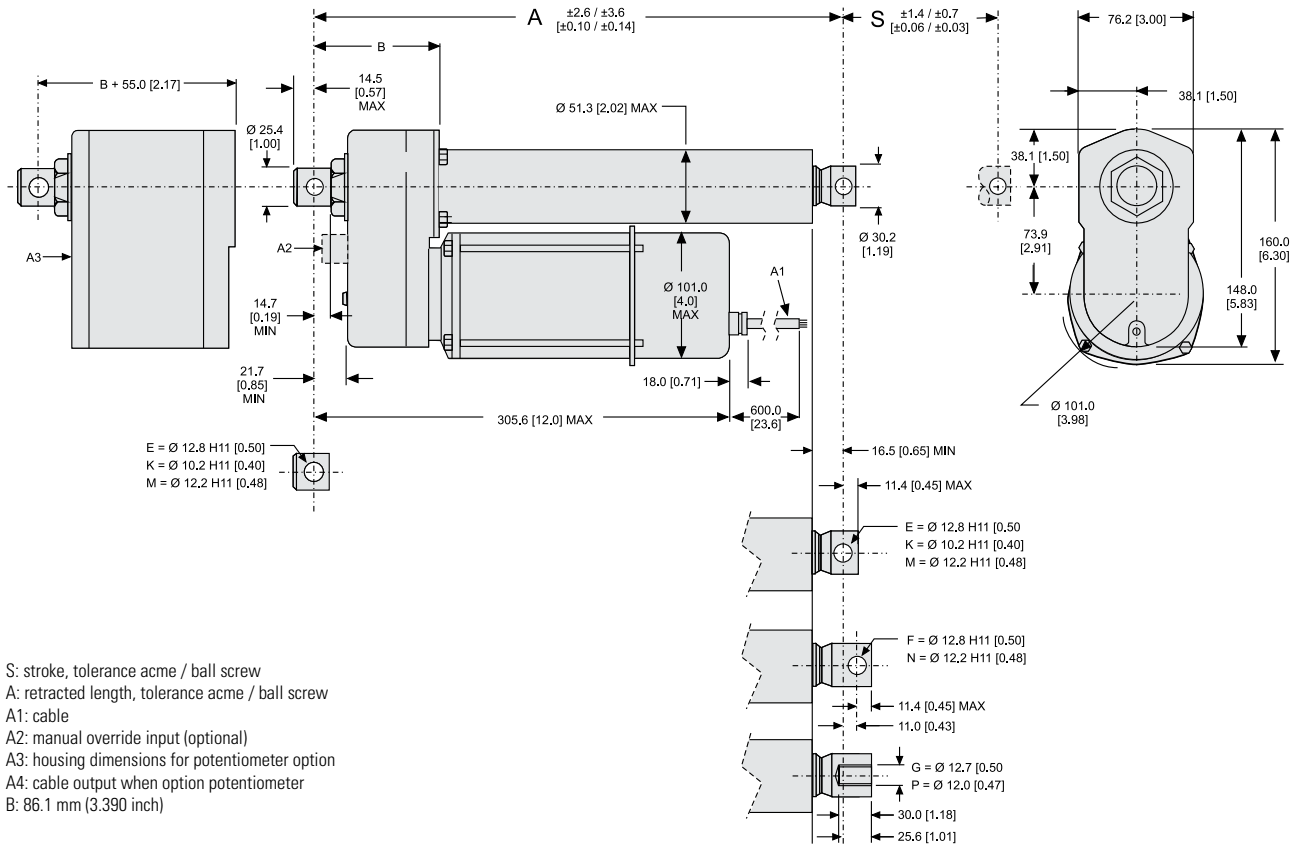

- S: stroke, tolerance acme / ball screw
- A: retracted length, tolerance acme / ball screw
- A1: cable
- A2: manual override input (optional)
- A3: housing dimensions for potentiometer option
- A4: cable output when option potentiometer
- B: 86.1 mm (3.390 inch)

## Stroke, Retracted Length and Weight Relationships

Ordering stroke (S)	[in]	6	8	10	12	14	16	18	20	22	24
Retracted length, acme screw models (A)	[mm]	312.9	363.7	414.5	465.3	583.7	634.5	685.3	736.1	786.9	837.7
	[in]	12.32	14.32	16.32	18.32	22.98	24.98	26.98	28.98	30.98	32.98
Retracted length, ball screw models (A)	[mm]	353.1	403.9	454.7	505.5	623.6	674.4	725.2	776.0	826.8	877.6
	[in]	13.90	15.90	17.90	19.90	24.55	26.55	28.55	30.55	32.55	34.55
Add on length for option potentiometer	[mm]	55.0									
	[in]	2.17									
Weight, acme screw models	[kg]	6.2	6.4	6.6	6.8	7.0	7.2	7.4	7.6	7.8	7.9
	[lbf]	13.6	14.1	14.5	15.0	15.4	15.8	16.3	16.7	17.1	17.4
Weight, ball screw models	[kg]	6.8	7.0	7.2	7.4	7.6	7.8	8.0	8.2	8.4	8.5
	[lbf]	15.0	15.4	15.8	16.3	16.7	17.1	17.6	18.0	18.5	18.8
Add on weight for option potentiometer	[kg]	1.30									
	[lbf]	2.86									

# Electrak® GX AC – Performance Diagrams

Load vs. Speed

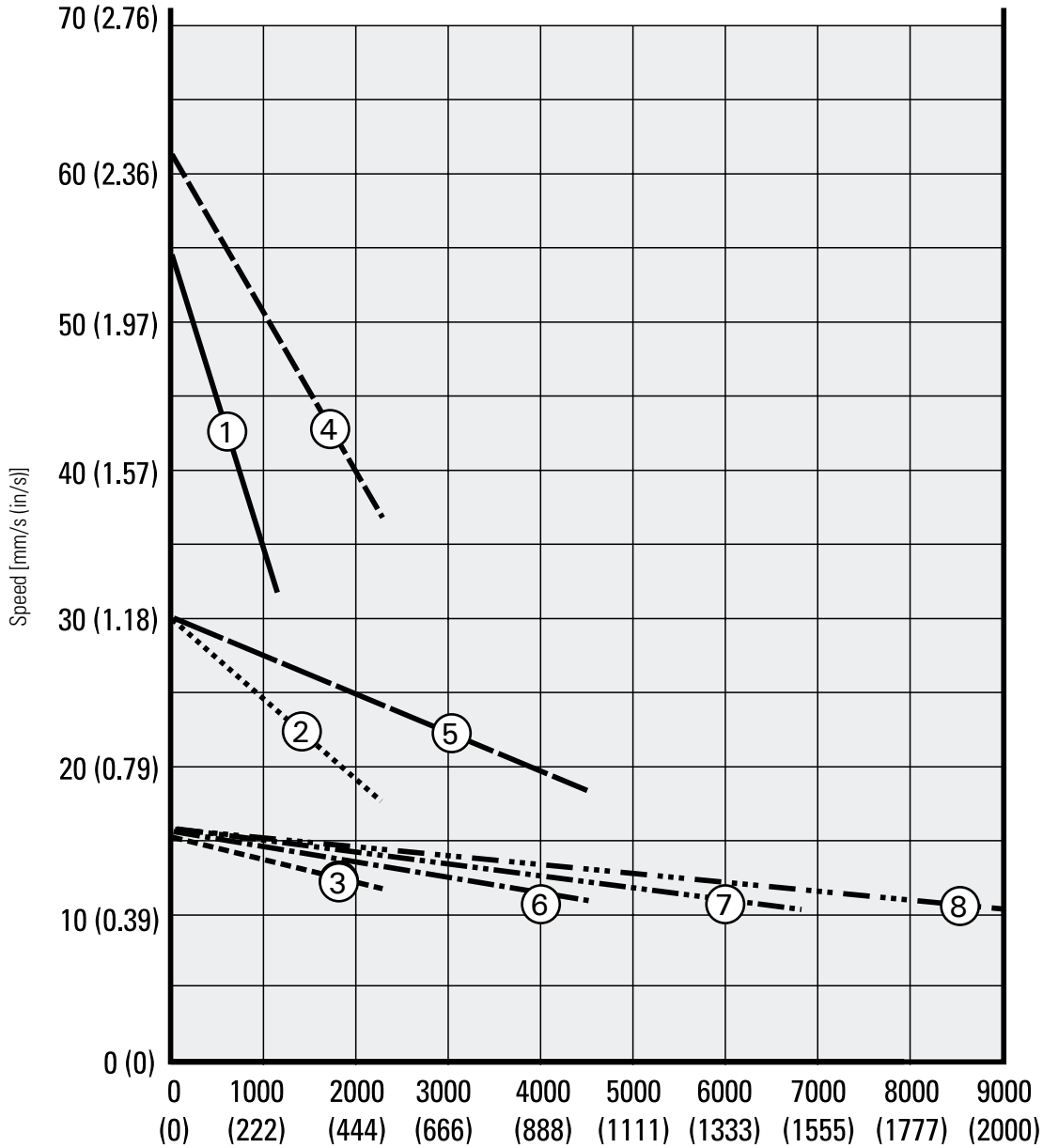

- |                                 |  |                                  |  |
|---------------------------------|--|----------------------------------|--|
| 1. Axxx-05A5 (1100 N (250 lbf)) |  | 5. Axxx-10B5 (4500 N (1000 lbf)) |  |
| 2. Axxx-10A5 (2250 N (500 lbf)) |  | 6. Axxx-20B5 (4500 N (1000 lbf)) |  |
| 3. Axxx-20A5 (2250 N (500 lbf)) |  | 7. Axxx-21B5 (6800 N (1500 lbf)) |  |
| 4. Axxx-05B5 (2250 N (500 lbf)) |  | 8. Axxx-2KB5 (9000 N (2000 lbf)) |  |

# Electrak® GX AC – Performance Diagrams

Load vs. Current for 1 × 115 and 1 × 230 Vac actuators

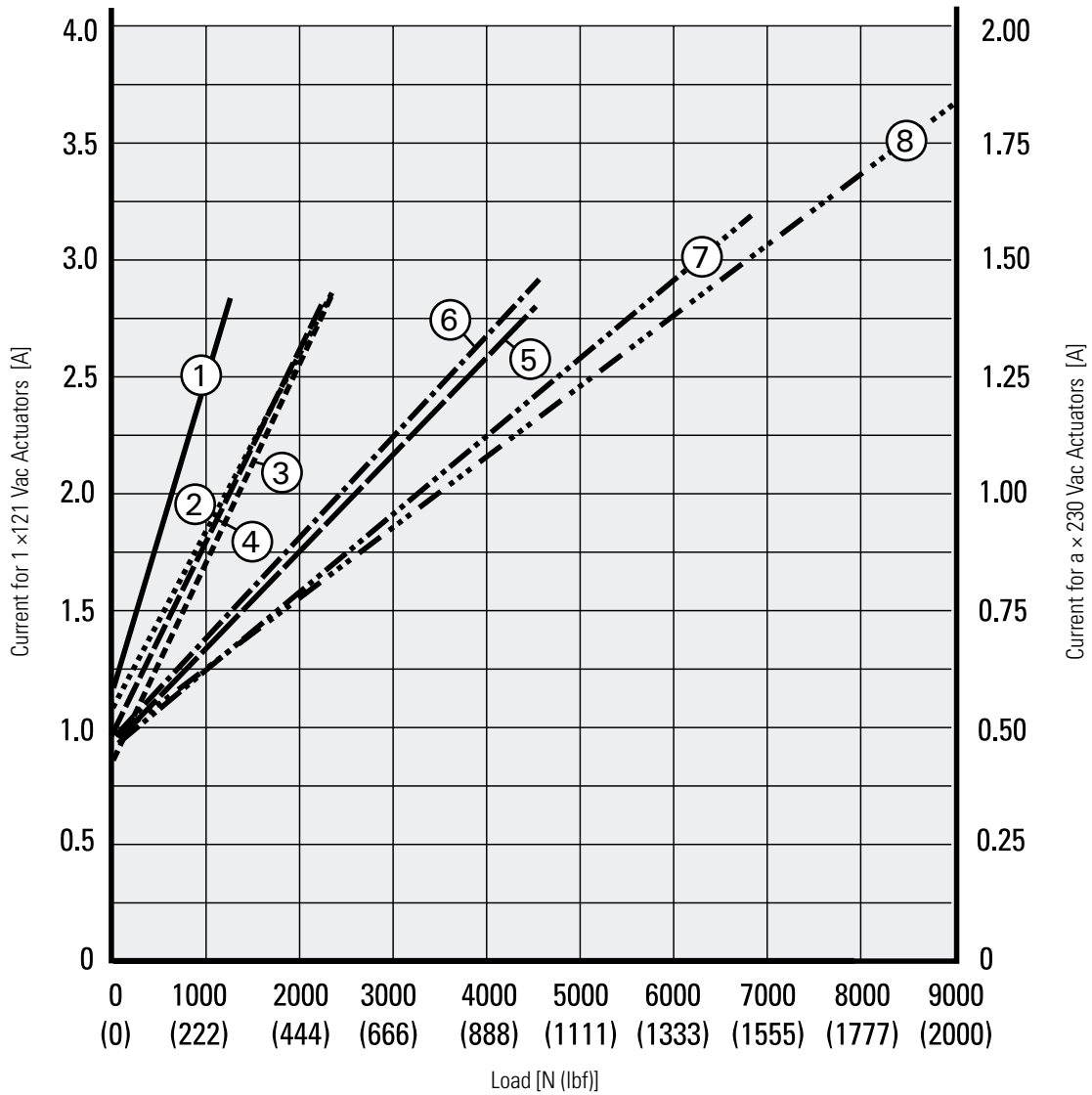

- |                                 |             |                                  |             |
|---------------------------------|-------------|----------------------------------|-------------|
| 1. Axxx-05A5 (1100 N (250 lbf)) | —————       | 5. Axxx-10B5 (4500 N (1000 lbf)) | —————       |
| 2. Axxx-10A5 (2250 N (500 lbf)) | .....       | 6. Axxx-20B5 (4500 N (1000 lbf)) | — · — · — · |
| 3. Axxx-20A5 (2250 N (500 lbf)) | -----       | 7. Axxx-21B5 (6800 N (1500 lbf)) | — · — · — · |
| 4. Axxx-05B5 (2250 N (500 lbf)) | — · — · — · | 8. Axxx-2KB5 (9000 N (2000 lbf)) | — · — · — · |



# Electrak<sup>®</sup> GX AC – Performance Diagrams

Load vs. Current for 3 × 400 Vac actuators

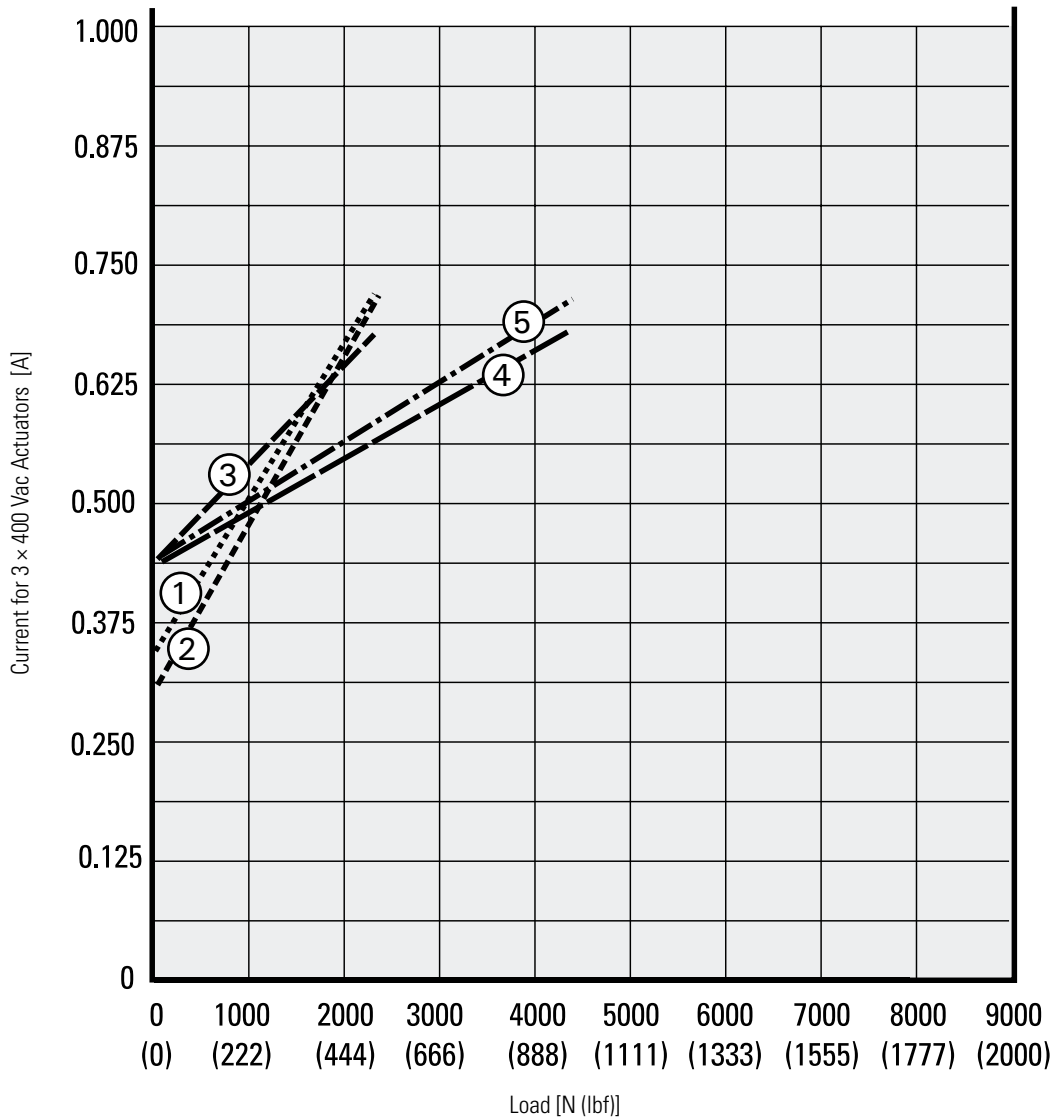

- |                                 |              |                                  |              |
|---------------------------------|--------------|----------------------------------|--------------|
| 1. Axxx-05A5 (1100 N (250 lbf)) | not possible | 5. Axxx-10B5 (4500 N (1000 lbf)) |              |
| 2. Axxx-10A5 (2250 N (500 lbf)) |              | 6. Axxx-20B5 (4500 N (1000 lbf)) |              |
| 3. Axxx-20A5 (2250 N (500 lbf)) |              | 7. Axxx-21B5 (6800 N (1500 lbf)) | not possible |
| 4. Axxx-05B5 (2250 N (500 lbf)) |              | 8. Axxx-2KB5 (9000 N (2000 lbf)) | not possible |

# Electrak® GX AC – Ordering Key

## Ordering Key

1	2	3	4	5	6	7	8	9
<b>A22C</b>	<b>05A5-</b>	<b>02</b>	<b>M0</b>	<b>B</b>	<b>N</b>	<b>D</b>	<b>E</b>	<b>E</b>

### 1. Model and input voltage

A12C = Electrak GX, 1 × 115 Vac, CE compliant  
A22C = Electrak GX, 1 × 230 Vac, CE compliant  
A42C = Electrak GX, 3 × 400 Vac, CE compliant  
A12N = Electrak GX, 1 × 115 Vac, not CE compliant  
A22N = Electrak GX, 1 × 230 Vac, not CE compliant  
A42N = Electrak GX, 3 × 400 Vac, not CE compliant

### 2. Dynamic load capacity, screw type, maximum speed

05A5 - = 1100 N, acme, 54 mm/s <sup>(1)</sup>  
10A5 - = 2250 N, acme, 30 mm/s  
20A5 - = 2250 N, acme, 15 mm/s  
05B5 - = 2250 N, ball, 61 mm/s  
10B5 - = 4500 N, ball, 30 mm/s  
20B5 - = 4500 N, ball, 15 mm/s  
21B5 - = 6800 N, ball, 15 mm/s <sup>(1)(2)</sup>  
2KB5 - = 9000 N, ball, 10 mm/s <sup>(1)(3)</sup>

### 3. Ordering stroke length

06 = 6 inch (152.4 mm)  
08 = 8 inch (203.2 mm)  
10 = 10 inch (254.0 mm)  
12 = 12 inch (304.8 mm)  
14 = 14 inch (355.6 mm)  
16 = 16 inch (406.4 mm)  
18 = 18 inch (457.2 mm)  
20 = 20 inch (508.0 mm)  
22 = 22 inch (558.8 mm)  
24 = 24 inch (609.6 mm)

### 4. Rear adapter hole orientation

M0 = adapter at 0° (standard)  
M3 = adapter at 90° <sup>(4)</sup>

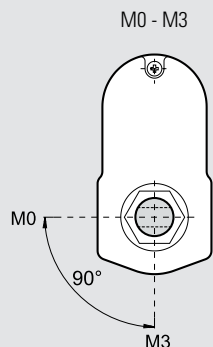

### 5. Ingress protection rating

B = IP45

### 6. Options

N = no option  
P = potentiometer feedback  
H = manual override

Dimensions for manual override option

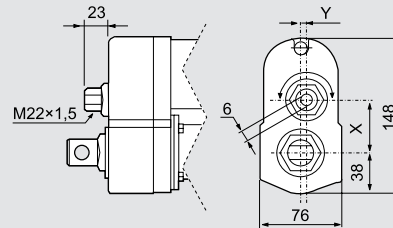

Model	X	Y
Axxx05A(B)5-	49.6	0.0
Axxx10A(B)5-	43.3	5.2
Axxx20(21, 2K)A(B)5-	38.9	0.0

### 7. Connector option

D = no connector (flying leads)

### 8. Front adapter option

E = cross hole for 0.5 inch pin  
F = forked cross hole for 0.5 inch pin  
G = 0.5 inch female thread  
K = cross hole for 10 mm pin  
M = cross hole for 12 mm pin  
N = forked cross hole for 12 mm pin  
P = 12 mm female thread

### 9. Rear adapter option

E = cross hole for 0.5 inch pin  
K = cross hole for 10 mm pin  
M = cross hole for 12 mm pin

(1) 05A5, 21B5 and 2KB5 not possible with 400 Vac input voltage

(2) 21B5 not possible with strokes above 20 inch

(3) 2KB5 not possible for strokes above 12 inch

(4) Not possible with option manual override

# Electrak<sup>®</sup> GX AC – Electrical Connections

## Input Voltage 230 Vac

Actuator supply voltage	[Vac]	
A12x		1 × 115
A22x		1 × 230

### Acme screw models (no anti-coast brake)

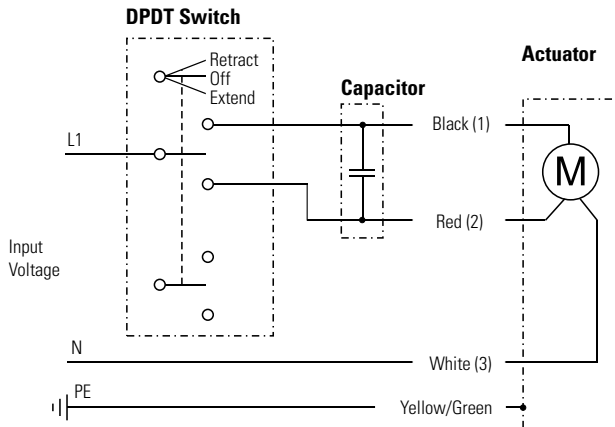

### Ball screw models (with anti-coast brake)

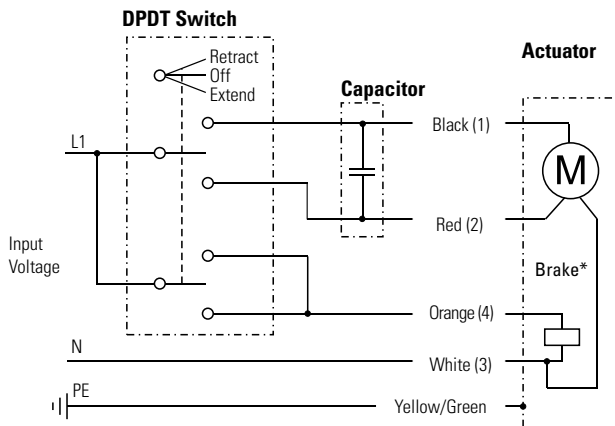

Leads can be either color or number marked. To be able to run the actuator, a capacitor must be connected between black (1) and red (2) leads. A 115 Vac actuator requires a 35  $\mu$ F capacitor, while a 230 Vac actuator requires a 10  $\mu$ F capacitor. See page 54 for ordering of capacitors. Connect black (1) lead to L1 and white (3) lead to N (neutral) to retract the actuator. Change L1 from lead black (1) to lead red (2) to extend the actuator. Ball screw models have an anti-coast brake\* that must be released during motion, which is done by connecting orange (4) lead to L1. Acme models do not have any anti-coast brake.

## Input Voltage 400 Vac

Actuator supply voltage	[Vac]	
A42x		3 × 400

### Acme screw models (no anti-coast brake)

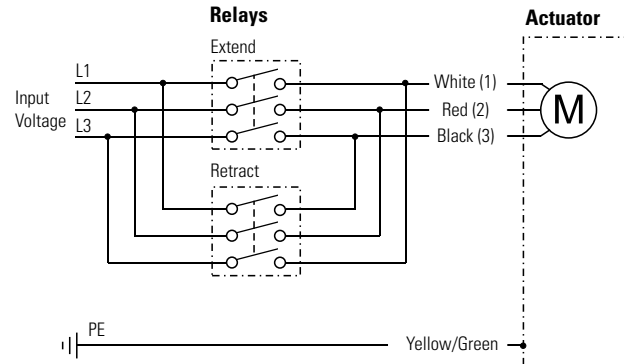

### Ball screw models (with anti-coast brake)

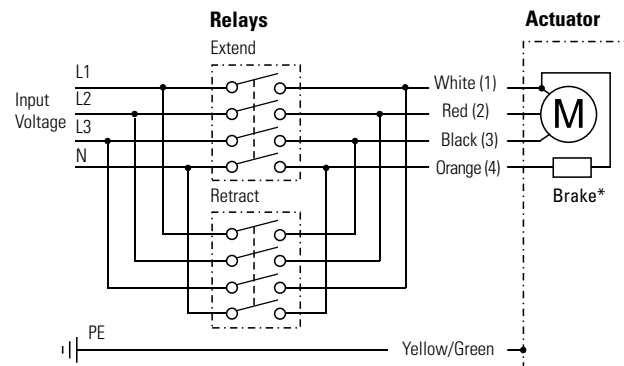

Leads can be either color or number marked. Connect white (1) lead to L1, red (2) lead to L2 and black (3) lead to L3 to extend the actuator. Change the places of white (2) lead and black (3) to retract the actuator. Ball screw models have an anti-coast brake\* that must be released during motion, which is done by connecting orange (4) to N (neutral). Acme models do not have any anti-coast brake.

# Electrak® GX AC – Electrical Connections

## Input Voltage 115 or 230 Vac + Option Potentiometer

Actuator supply voltage	[Vac]	1 × 115 1 × 230
Actuator type		A12x A22x
Potentiometer type		wire-wound
Potentiometer max. input voltage	[Vdc]	32
Potentiometer max. power	[W]	2
Potentiometer linearity	[%]	± 0.25
Potentiometer output resolution	[ohm/mm]	39 20 10
		2 - 10 inch stroke 11 - 20 inch stroke 21 - 24 inch stroke

Leads can be either color or number marked. To be able to run the actuator, a capacitor must be connected between black (1) and red (2) leads. A 115 Vac actuator requires a 35 µF capacitor, while a 230 Vac actuator requires a 10 µF capacitor. See page 54 for ordering of capacitors. Connect black (1) lead to L1 and white (3) lead to N (neutral) to retract the actuator. Change L1 from lead black (1) to lead red (2) to extend the actuator. Ball screw models have an anti-coast brake\* that must be released during motion, which is done by connecting orange (4) lead to L1. Acme models do not have any anti-coast brake. The potentiometer output cable has 0 ohm between gray and yellow leads when the actuator is fully extended.

### Acme screw models (no anti-coast brake)

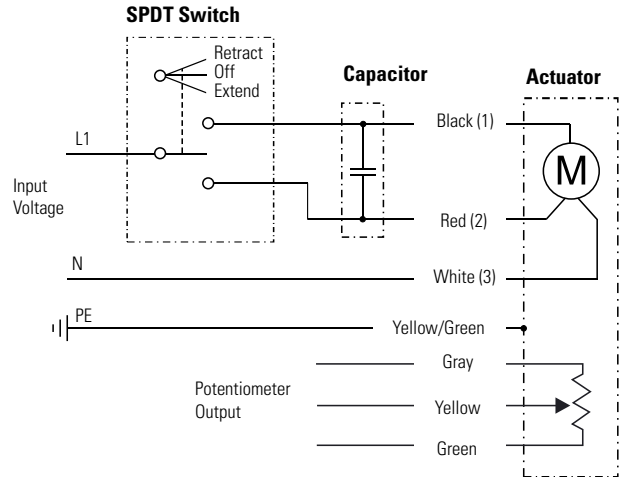

### Ball screw models (with anti-coast brake)

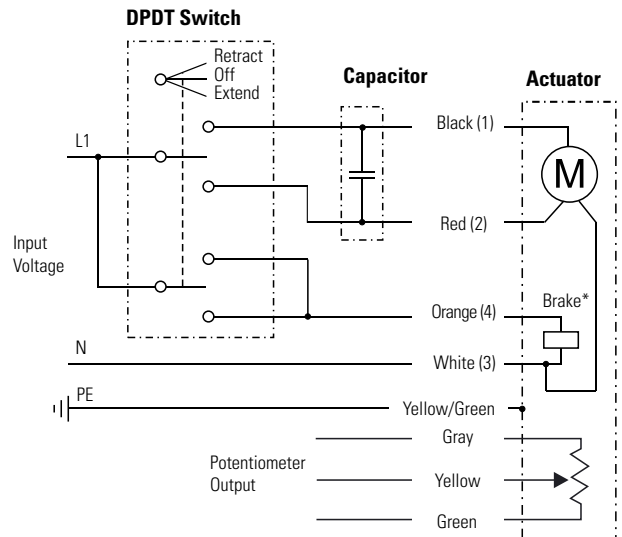

# Electrak<sup>®</sup> GX AC – Electrical Connections

Input Voltage 400 Vac + Option Potentiometer		
Actuator supply voltage A42x	[Vac]	3 × 400
Potentiometer type		wire-wound
Potentiometer max. input voltage	[Vdc]	32
Potentiometer max. power	[W]	2
Potentiometer linearity	[%]	± 0.25
Potentiometer output resolution	[ohm/mm]	
2 - 10 inch stroke		39
11 - 20 inch stroke		20
21 - 24 inch stroke		10

Leads can be either color or number marked. Connect white (1) lead to L1, red (2) lead to L2 and black (3) lead to L3 to extend the actuator. Change the places of white (2) lead and black (3) to retract the actuator. Ball screw models have an anti-coast brake\* that must be released during motion, which is done by connecting orange (4) lead to N (neutral). Acme models do not have any anti-coast brake. The potentiometer output cable has 0 ohm between gray and yellow leads when the actuator is fully extended.

### Acme screw models (no anti-coast brake)

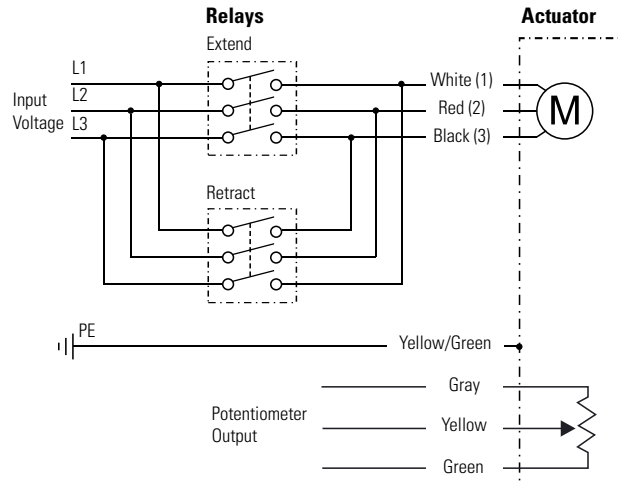

### Ball screw models (with anti-coast brake)

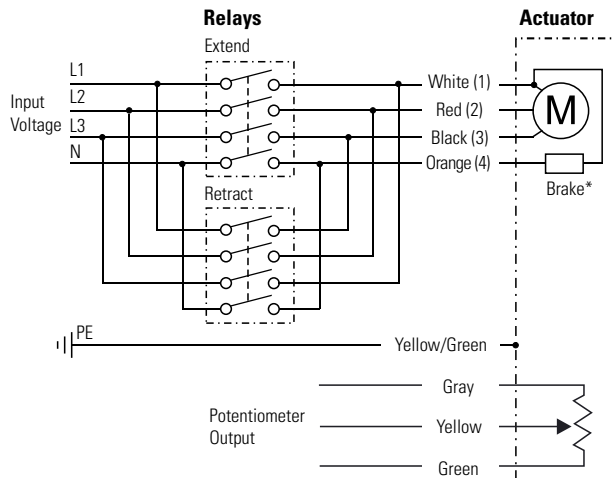

## Electrak® GX AC – Accessories

### Mounting Pin Kits

Designation	A [mm(in)]	Part Number
Mounting pins (pair)	12.7 (0.5)	D603 028

The mounting pins are used in the rear and front adapter holes of the actuator. The pins have a groove in each end so that it can be secured with snap rings.

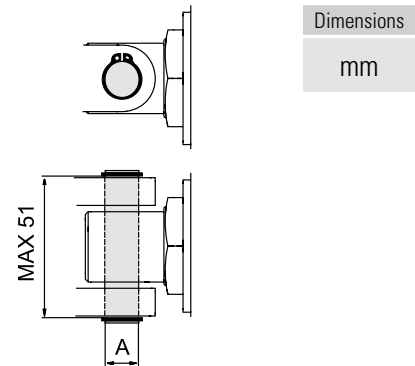

### Capacitor Kits

Designation	Actuator Supply Voltage	Part Number
Capacitor kit	115 Vac	9200-448-002
Capacitor kit	230 Vac	9200-448-003

All 230 and 115 Vac actuators require a capacitor to be wired between the windings to run. The capacitor is bought separately and mounted externally by the customer.



# Electrak® LA14 – Technical Features



## Standard Features

- Robust and reliable
- 12, 24 or 36 Vdc as standard input voltages
- Acme and ball screw models
- Static load up to 18 kN (4000 lbf)
- Dynamic load up to 6.8 kN (1500 lbf)
- Stroke up to 24 in
- Speed up to 61 mm/s (2.4 in/s)
- Protection class static IP65
- Overload clutch for mid and end of stroke protection
- Motor with thermal switch
- Corrosion free aluminium cover tube
- Anti-rotation mechanism
- T-slots in the cover tube for magnetic sensors
- Trunnion mounting possible
- Maintenance free

## General Specifications

Screw type	acme or ball
Nut type Dxx-xxA (acme screw) Dxx-xxB (ball screw)	self-locking lead nut load lock ball nut
Manual override	no (optional)
Anti-rotation	yes
Static load holding brake acme screw models ball screw models	no (self-locking) yes
Safety features	overload clutch motor auto reset thermal switch
Electrical connections no potentiometer option with potentiometer option	flying leads with or without connector cable with or without connector
Compliances	CE

## Optional Mechanical Features

Variety of front and rear adapters

Variety of rear adapter orientations

Manual override

## Optional Electrical Features

Potentiometer feedback

## Accessories

External slot-mounted limit switches

Mounting pin kits

Mounting pin bracket kits

Trunnions mounting kits

## Compatible Controls

Contact customer support at [www.thomsonlinear.com/cs](http://www.thomsonlinear.com/cs)



# Electrak<sup>®</sup> LA14 – Technical Specifications

Mechanical Specifications		
Max. static load <sup>(1)</sup>	[N (lbf)]	
DAxx-xxA (acme screw)		11350 (2500)
DAxx-xxB (ball screw)		18000 (4000)
Max. dynamic load (Fx)	[N (lbf)]	
DAxx-05A65M		1100 (250)
DAxx-10A65M		2250 (500)
DAxx-20A65M		2250 (500)
DAxx-05B65M		2250 (500)
DAxx-10B65M		4500 (1000)
DAxx-20B65M		4500 (1000)
DAxx-21B65M		6800 (1500)
Speed @ no load/max. load	[mm/s (in/s)]	
DAxx-05A65M		54/32 (2.10/1.20)
DAxx-10A65M		30/18 (1.20/0.70)
DAxx-20A65M		15/12 (0.67/0.45)
DAxx-05B65M		61/37 (2.40/1.40)
DAxx-10B65M		30/19 (1.30/0.80)
DAxx-20B65M		15/12 (0.60/0.45)
DAxx-21B65M		15/11 (0.60/0.43)
Min. ordering stroke (S) length	[mm]	50
Max. ordering stroke (S) length <sup>(2)</sup>	[mm]	600
Ordering stroke length increments	[mm]	50
Operating temperature limits	[°C (F)]	-25 – 85 (-15 – 185)
Full load duty cycle @ 25 °C (77 °F)	[%]	25
End play, maximum	[mm (in)]	1.0 (0.04)
Restraining torque	[Nm (lbf-in)]	0
Protection class - static		IP65
Salt spray resistance	[h]	96

(1) Max. static load at fully retracted stroke

Electrical Specifications		
Available input voltages <sup>(1)</sup>	[Vdc]	12, 24, 36
Input voltage tolerance	[%]	± 10
Current draw @ no load/max. load <sup>(2)</sup>	[A]	
DA12-05A65M		12.0/34.0
DA12-10A65M		9.0/27.0
DA12-20A65M		8.0/15.0
DA12-05B65M		8.0/26.0
DA12-10B65M		5.0/26.0
DA12-20B65M		4.0/14.0
DA12-21B65M		4.0/19.0
DA24-05A65M		6.0/17.0
DA24-10A65M		4.5/13.5
DA24-20A65M		4.0/7.5
DA24-05B65M		4.0/13.0
DA24-10B65M		2.5/13.0
DA24-20B65M		2.0/7.0
DA24-21B65M		2.0/9.5
Flying leads length	[mm (in)]	165 (7.5)
Flying leads diameter	[mm (in)]	3 (0.12)
Flying leads cross section	[mm <sup>2</sup> (AWG)]	2 (14)
Cable length with option pot.	[mm (in)]	600 (24)
Cable diameter with option pot.	[mm (in)]	9 (0.35)
Cable leads cross section with option potentiometer	[mm <sup>2</sup> (AWG)]	
motor leads		2.5 (14)
potentiometer leads		1.5 (16)

(1) For other input voltages - contact customer support

(2) For current draw for 36 Vdc input voltage models - contact customer support

# Electrak® LA14 – Dimensions

Dimensions	Projection
mm [inch]	

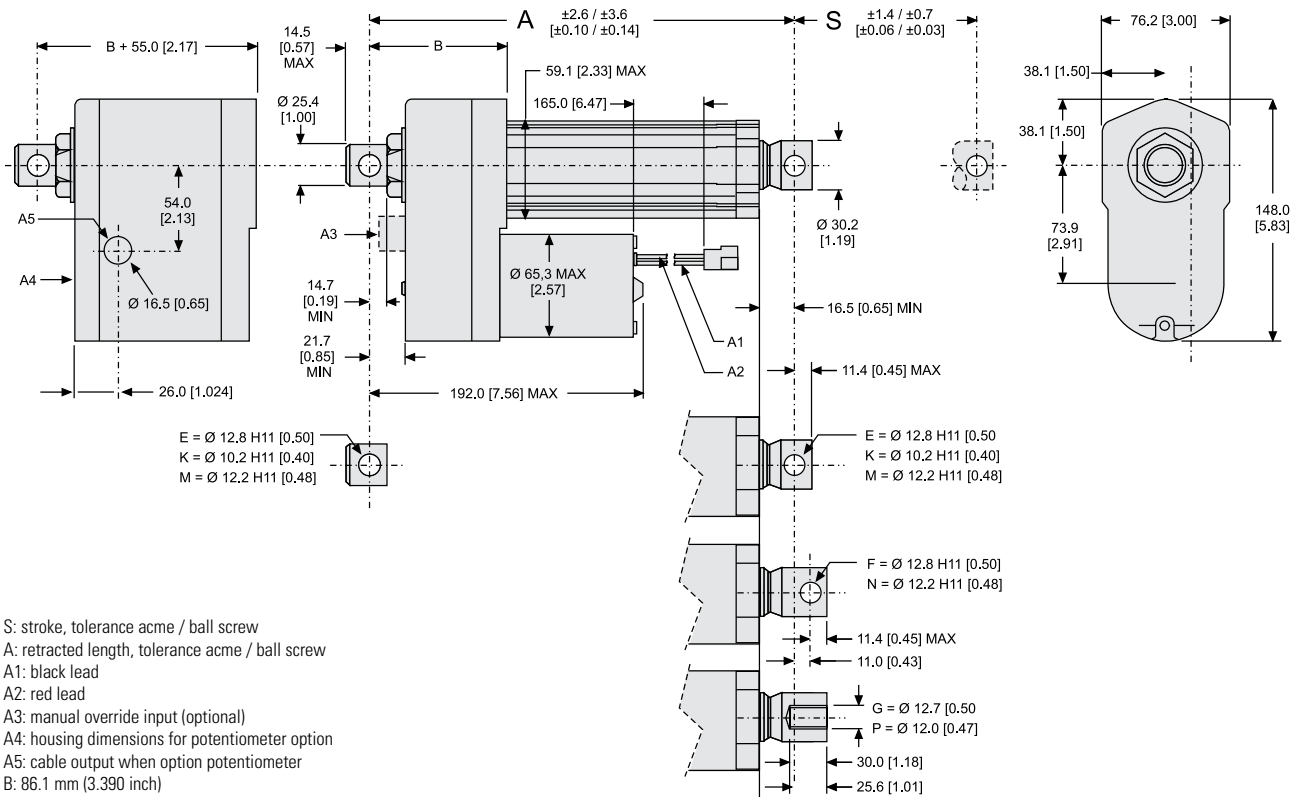

- S: stroke, tolerance acme / ball screw
- A: retracted length, tolerance acme / ball screw
- A1: black lead
- A2: red lead
- A3: manual override input (optional)
- A4: housing dimensions for potentiometer option
- A5: cable output when option potentiometer
- B: 86.1 mm (3.390 inch)

## Stroke, Retracted Length and Weight Relationships

Ordering stroke (S)	[mm]	50	100	150	200	250	300	350	400	450	500	550	600
Retracted length, acme screw models (A)	[mm]	216.7	266.7	316.7	366.7	416.7	466.7	566.7	616.7	666.7	716.7	766.7	816.7
	[in]	8.53	10.50	12.47	14.44	16.41	18.37	22.31	24.28	26.25	28.22	30.19	32.15
Retracted length, ball screw models (A)	[mm]	269.6	319.6	369.6	419.6	469.6	519.6	619.6	669.6	719.6	769.6	819.6	869.6
	[in]	10.61	12.58	14.55	16.52	18.49	20.46	24.39	26.36	28.33	30.30	32.27	34.24
Add on length for option potentiometer	[mm]	55.0											
	[in]	2.17											
Weight, acme screw models	[kg]	4.5	4.7	4.9	5.1	5.3	5.5	5.8	6.0	6.2	6.4	6.6	6.8
	[lbf]	9.9	10.3	10.8	11.2	11.7	12.1	12.8	13.2	13.6	14.1	14.5	15.0
Weight, ball screw models	[kg]	5.3	5.5	5.7	5.9	6.1	6.3	6.6	6.8	7.0	7.2	7.4	7.6
	[lbf]	11.7	12.1	12.5	13.0	13.4	13.9	14.5	15.0	15.4	15.8	16.3	16.7
Add on weight for option potentiometer	[kg]	1.30											
	[lbf]	3.31											

# Electrak® LA14 – Performance Diagrams

Acme Screw Models  
Speed and Current vs. Load

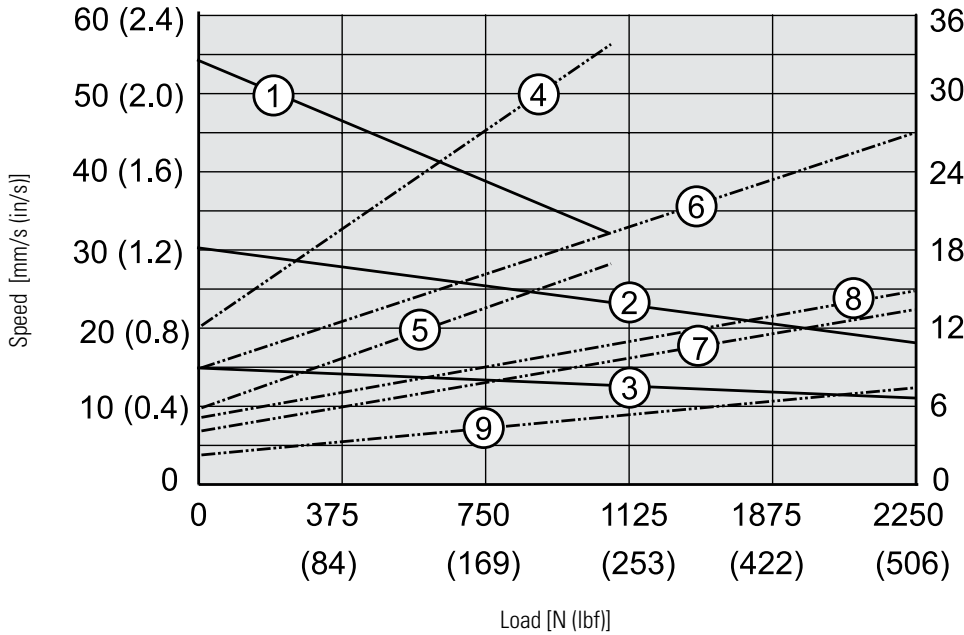

Speed  
1: DAxx-05A65M  
2: DAxx-10A65M  
3: DAxx-20A65M

Current  
4: DA12-05A65M  
5: DA24-05A65M  
6: DA12-10A65M  
7: DA24-10A65M  
8: DA12-20A65M  
9: DA24-20A65M

Ball Screw Models  
Speed and Current vs. Load

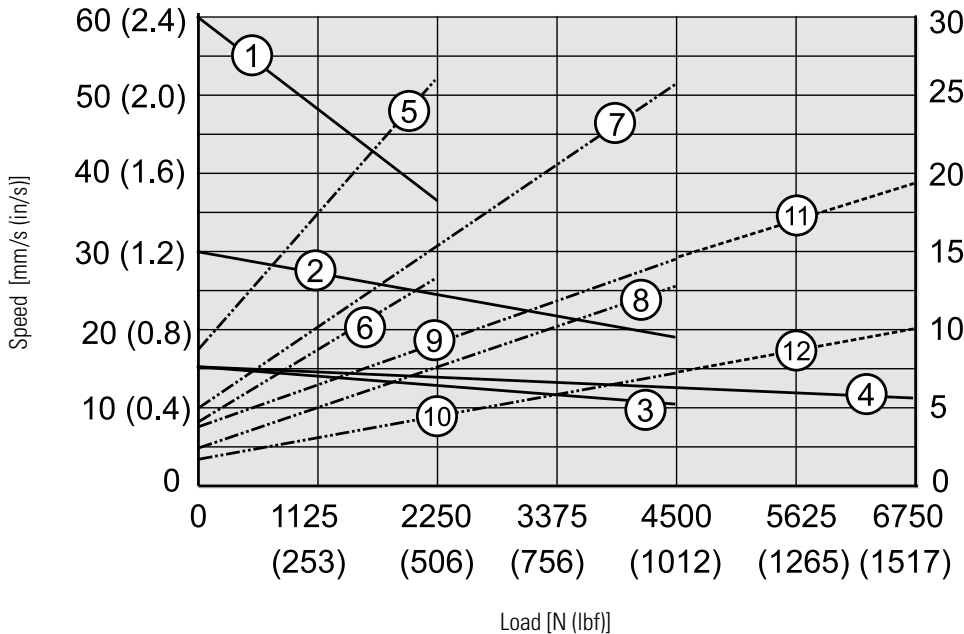

Speed  
1: DAxx-05B65M  
2: DAxx-10B65M  
3: DAxx-20B65M  
4: DAxx-21B65M

Current  
5: DA12-05B65M  
6: DA24-05B65M  
7: DA12-10B65M  
8: DA24-10B65M  
9: DA12-20B65M  
10: DA24-20B65M  
11: DA12-21B65M  
12: DA24-21B65M

Note: for current draw data for 36 Vdc input voltage models - contact customer support.

# Electrak® LA14 – Ordering Key

## Ordering Key

1	2	3	4	5	6	7	8
<b>DA12-</b>	<b>05A65M</b>	<b>10</b>	<b>M0</b>	<b>N</b>	<b>A</b>	<b>F</b>	<b>M</b>

### 1. Model and input voltage

DA12- = Electrak LA14, 12 Vdc  
DA24- = Electrak LA14, 24 Vdc  
DA36- = Electrak LA14, 36 Vdc

### 2. Dynamic load capacity, screw type, maximum speed

05A65M = 1100 N, acme, 54 mm/s  
10A65M = 2250 N, acme, 30 mm/s  
20A65M = 2250 N, acme, 15 mm/s  
05B65M = 2250 N, ball, 61 mm/s  
10B65M = 4500 N, ball, 30 mm/s  
20B65M = 4500 N, ball, 15 mm/s  
21B65M = 6800 N, ball, 15 mm/s

### 3. Ordering stroke length

05 = 50 mm (1.97 in)  
10 = 100 mm (3.94 in)  
15 = 150 mm (5.90 in)  
20 = 200 mm (7.87 in)  
25 = 250 mm (9.84 in)  
30 = 300 mm (11.81 in)  
35 = 350 mm (13.78 in)  
40 = 400 mm (15.75 in)  
45 = 450 mm (17.72 in)  
50 = 500 mm (19.69 in)  
55 = 550 mm (21.65 in)  
60 = 600 mm 23.62 in)

### 4. Rear / front adapter hole position <sup>(1)</sup>

M0 = both adapters at 0° (standard position)  
M1 = rear adapter at 30°, front at 0°  
M2 = rear adapter at 60°, front at 0°  
M3 = rear adapter at 90°, front at 0°  
M4 = rear adapter at 120°, front at 0°  
M5 = rear adapter at 150°, front at 0°  
MF = rear and front adapter at 90°

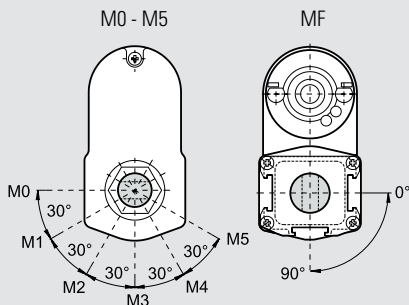

### 5. Options

N = no option  
NPO = potentiometer feedback  
NHW = manual override <sup>(1)</sup>

Dimensions for manual override option

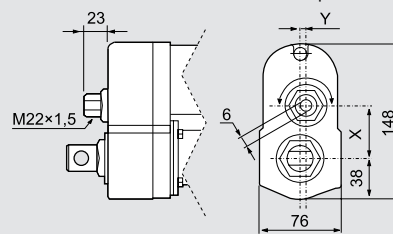

Model	X	Y
DAxx05A(B)65-	49.6	0.0
DAxx10A(B)65-	43.3	5.2
DAxx20(21)A(B)65-	38.9	0.0

### 6. Connector option

A = AMP terminal 42098-2, house 180908-5  
D = no connector (flying leads)

### 7. Front adapter option

E = cross hole for 0.5 inch pin  
F = forked cross hole for 0.5 inch pin  
G = 0.5 inch female thread  
K = cross hole for 10 mm pin  
M = cross hole for 12 mm pin  
N = forked cross hole for 12 mm pin  
P = 12 mm female thread

### 8. Rear adapter option

E = cross hole for 0.5 inch pin  
K = cross hole for 10 mm pin  
M = cross hole for 12 mm pin

(1) Only adapter position M0 possible with option manual override.

# Electrak<sup>®</sup> LA14 – Electrical Connections

## Without Option

Actuator supply voltage	[Vdc]	
DA12		12
DA24		24
DA36		36

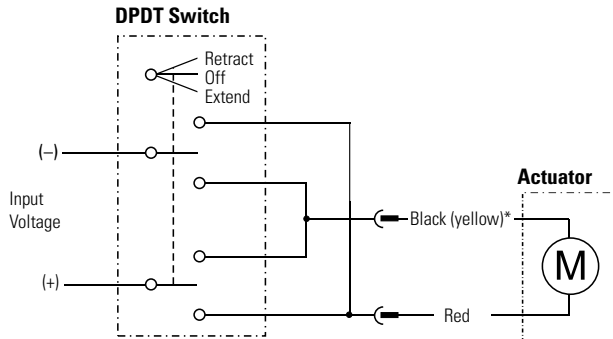

\* Lead can be black or yellow

Connect the red lead to positive and black (yellow)\* to negative to extend the actuator. Change polarity to retract the actuator.

## Option Potentiometer

Actuator supply voltage	[Vdc]	
DA12		12
DA24		24
DA36		36
Potentiometer type		wire-wound
Potentiometer max. input voltage	[Vdc]	32
Potentiometer max. power	[W]	2
Potentiometer linearity	[%]	± 0.25
Potentiometer output resolution	[ohm/mm]	
50 - 255 mm stroke		39
256 - 510 mm stroke		20
511 - 600 mm stroke		10

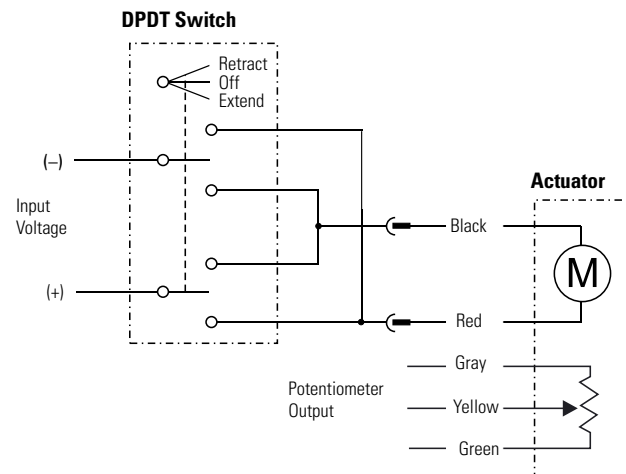

Connect the red lead to positive and black to negative to extend the actuator. Change polarity to retract the actuator. The potentiometer output cable has 0 ohm between gray and yellow leads when the actuator is fully extended.

# Electrak® LA14 – Accessories

## Mounting Pin Kits

Designation	A [mm (in)]	Part Number
Mounting pins (pair)	12 (0.47)	D603 023

The mounting pins are used in the rear and front adapter holes of the actuator. The pins have a groove in each end so that it can be secured with snap rings.

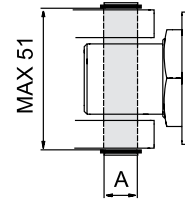

Dimensions  
mm

## Magnetic Sensor

Designation	Contact Type	Part Number
Magnetic sensor	normally open	D535 070
Magnetic sensor	normally closed	D535 071
Magnetic sensor	changing	D535 073

## Specifications

Parameter		D535 070	D535 073
		D535 071	
Maximum power	[W]	10	10
Maximum voltage	[Vdc]	43	43
Maximum current	[A]	0,5	0,5
Maximum contact resistance	[ohm]	0,2	0,2
Lead cross section	[mm <sup>2</sup> ]	2 × 0,14	3 × 0,14
Cable length	[mm]	3000	3000
Protection class		IP67	IP67

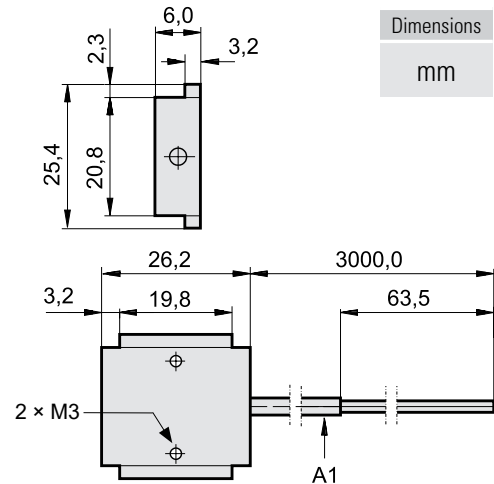

Dimensions  
mm

A1: cable

The magnetic sensor fits in to the T-slot running along three sides of the cover tube. The cable is moulded into the sensor.

# Electrak<sup>®</sup> LA14 – Accessories

## Mounting Pin Bracket Kits

Designation	Part Number
Mounting pin brackets (pair)	D603 029

The mounting pin brackets are used to attach the front and rear adapter via a pair of mounting pins to the objects to which it is mounted. Note! one pair of brackets is needed per adapter as there must be a bracket on each side of the adapter.

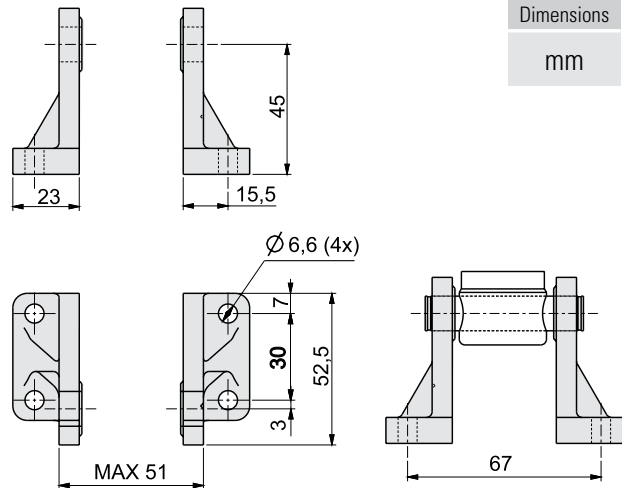

Dimensions  
mm

## Trunnion Mounting Kits

Designation	Part Number
Trunnions (pair)	D603 022
Trunnion brackets (pair)	D603 030

The trunnions can be mounted to the T-slot running along the right and left side of the cover tube.

### Trunnions

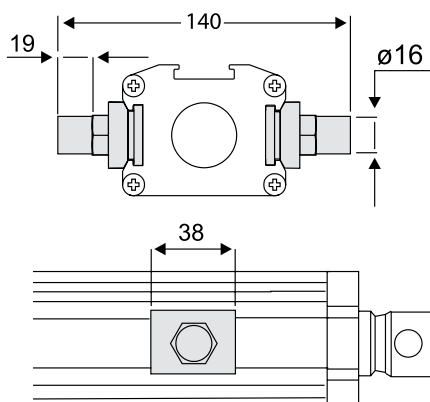

Dimensions  
mm

### Trunnion Brackets

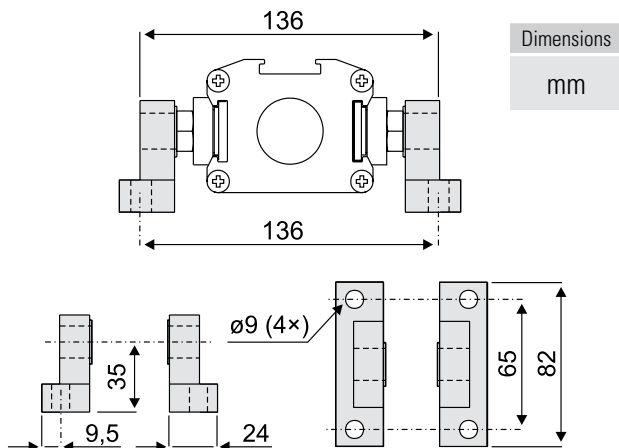

Dimensions  
mm

# Electrak® LA24 – Technical Features



## Standard Features

- Robust and reliable
- 1 × 230 or 3 × 400 Vac as standard input voltages
- Acme and ball screw models
- Static load up to 18 kN (4000 lbf)
- Dynamic load up to 6.8 kN (1500 lbf)
- Stroke up to 24 in
- Speed up to 61 mm/s (2.4 in/s)
- Protection class static IP45
- Overload clutch for mid and end of stroke protection
- Motor with thermal switch
- Corrosion free aluminium cover tube
- Anti-rotation mechanism
- T-slots in the cover tube for magnetic sensors
- Maintenance free

## General Specifications

Screw type	acme or ball
Nut type Dxx-xxA (acme screw) Dxx-xxB (ball screw)	self-locking lead nut load lock ball nut
Manual override	no (optional)
Anti-rotation	yes
Static load holding brake acme screw models ball screw models	no (self-locking) yes
Safety features	overload clutch motor auto reset thermal switch
Electrical connections no potentiometer option with potentiometer option	cable with flying leads 2 x cable with flying leads
Compliances	CE
Certificates	UL, CSA

(1) Mating connector: 2973781 with terminal 2962573 (p/n 9100-448-001)

## Optional Mechanical Features

- Variety of front and rear adapters
- Variety of rear adapter orientations
- Manual override

## Optional Electrical Features

- Potentiometer feedback
- Anti-coast brake

## Accessories

- External slot-mounted limit switches
- Mounting pin kits
- Mounting pin bracket kits
- Trunnions mounting kits
- Capacitors

## Compatible Controls

Contact customer support at [www.thomsonlinear.com/cs](http://www.thomsonlinear.com/cs)



# Electrak<sup>®</sup> LA24 – Technical Specifications

Mechanical Specifications		
Max. static load <sup>(1)</sup> Axx-xxA (acme screw) Axx-xxB (ball screw)	[N (lbf)]	11350 (2500) 18000 (4000)
Max. dynamic load (Fx) AAxx-05A65M <sup>(2)</sup> AAxx-10A65M AAxx-20A65M AAxx-05B65M AAxx-10B65M AAxx-20B65M AAxx-21B65M	[N (lbf)]	1100 (250) 2250 (500) 2250 (500) 2250 (500) 4500 (1000) 4500 (1000) 6800 (1500)
Speed @ no load/max. load AAxx-05A65M <sup>(2)</sup> AAxx-10A65M AAxx-20A65M AAxx-05B65M AAxx-10B65M AAxx-20B65M AAxx-21B65M	[mm/s (in/s)]	54/32 (2.10/1.20) 30/18 (1.20/0.70) 15/12 (0.67/0.45) 61/37 (2.40/1.40) 30/19 (1.30/0.80) 15/12 (0.60/0.45) 15/11 (0.60/0.43)
Min. ordering stroke (S) length	[mm]	50
Max. ordering stroke (S) length <sup>(3)</sup>	[mm]	600
Ordering stroke length increments	[mm]	50
Operating temperature limits	[°C (F)]	-25 – 65 (-15 – 150)
Max. on time	[s]	45
Full load duty cycle @ 25 °C (77 °F)	[%]	25
End play, maximum	[mm (in)]	1.0 (0.04)
Restraining torque	[Nm (lbf-in)]	0
Protection class - static		IP45
Salt spray resistance	[h]	96

(1) Max. static load at fully retracted stroke

(2) Not possible with supply voltage 3 × 400 Vac

(3) Max. ordering stroke length for Axx-2KB5 is 10 inches

Electrical Specifications		
Available input voltages <sup>(1)</sup>	[Vac]	1 × 230 <sup>(2)</sup> 3 × 400
Input voltage tolerance	[%]	± 10
Current draw @ no load/max. load AA22-05A65M AA22-10A65M AA22-20A65M AA22-05B65M AA22-10B65M AA22-20B65M AA22-21B65M AA42-10A65M AA42-20A65M AA42-05B65M AA42-10B65M AA42-20B65M AA42-21B65M	[A]	1.05/1.65 0.80/1.35 0.95/1.25 0.90/1.40 0.90/1.40 0.90/1.40 0.90/1.25 0.40/0.70 0.30/0.45 0.38/0.50 0.38/0.50 0.38/0.50 0.38/0.50
Motor cable length	[mm (in)]	600 (24)
Motor cable diameter	[mm (in)]	10 (0.4)
Motor cable leads cross section	[mm <sup>2</sup> (AWG)]	1.5 (16)
Potentiometer cable length <sup>(3)</sup>	[mm (in)]	500 (20)
Potentiometer cable diameter <sup>(3)</sup>	[mm (in)]	9 (0.35)
Pot. cable leads cross section <sup>(3)</sup>	[mm <sup>2</sup> (AWG)]	1.5 (16)

(1) For other input voltages - contact customer

(2) Capacitor required to run the actuator. 10 µF, p/n 9200-448-003

(3) Potentiometer is optional

# Electrak® LA24 – Dimensions

Dimensions	Projection
mm [inch]	

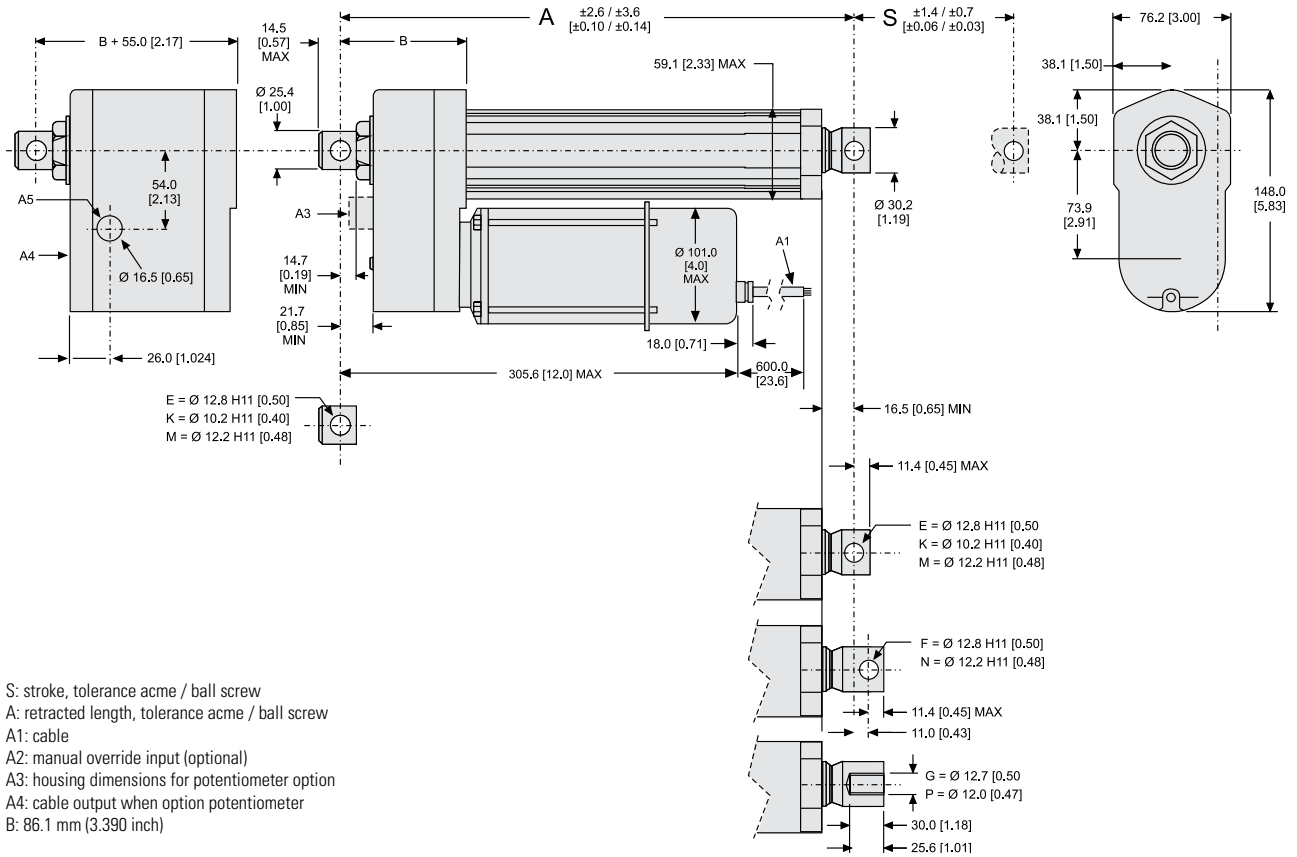

## Stroke, Retracted Length and Weight Relationships

Ordering stroke (S)	[mm]	50	100	150	200	250	300	350	400	450	500	550	600
Retracted length, acme screw models (A)	[mm]	216.7	266.7	316.7	366.7	416.7	466.7	566.7	616.7	666.7	716.7	766.7	816.7
	[in]	8.53	10.50	12.47	14.44	16.41	18.37	22.31	24.28	26.25	28.22	30.19	32.15
Retracted length, ball screw models (A)	[mm]	269.6	319.6	369.6	419.6	469.6	519.6	619.6	669.6	719.6	769.6	819.6	869.6
	[in]	10.61	12.58	14.55	16.52	18.49	20.46	24.39	26.36	28.33	30.30	32.27	34.24
Add on length for option potentiometer	[mm]	55.0											
	[in]	2.17											
Weight, acme screw models	[kg]	6.0	6.2	6.4	6.6	6.8	7.0	7.3	7.5	7.7	7.9	8.1	8.3
	[lbf]	13.2	13.6	14.1	14.5	15.0	15.4	16.1	16.5	16.9	17.4	17.8	18.3
Weight, ball screw models	[kg]	6.8	7.0	7.2	7.4	7.6	7.8	8.1	8.3	8.5	8.7	8.9	9.1
	[lbf]	15.0	15.4	15.8	16.3	16.7	17.2	17.8	18.3	18.7	19.1	19.6	20.0
Add on weight for option potentiometer	[kg]	1.30											
	[lbf]	3.31											

# Electrak<sup>®</sup> LA24 – Performance Diagrams

Acme Screw Models  
Speed and Current vs. Load

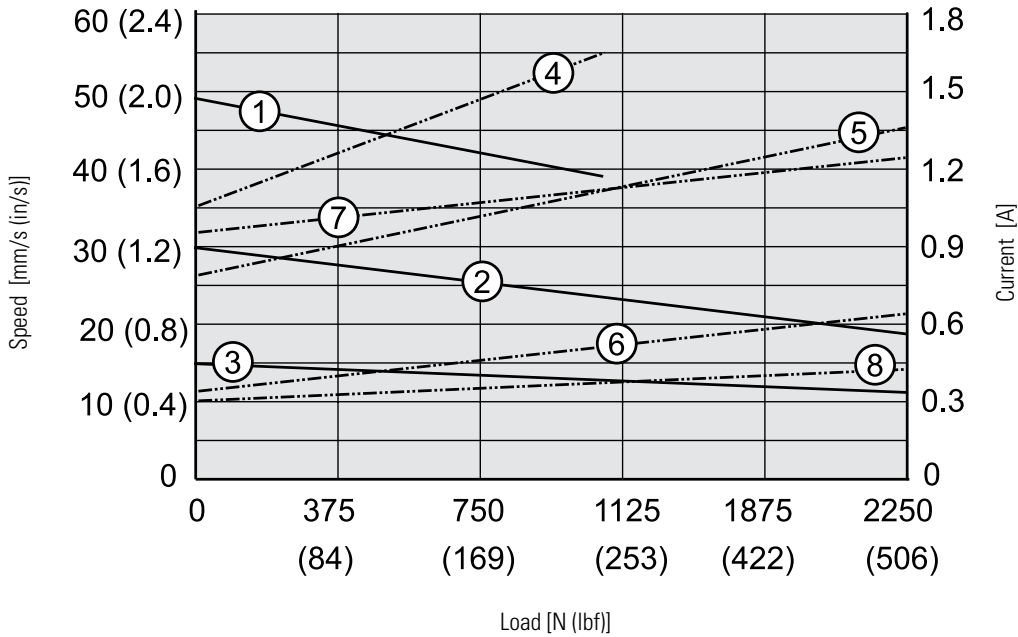

- Speed  
 1: AA22-05A65M  
 2: AAxx-10A65M  
 3: AAxx-20A65M

- Current  
 4: AA22-05A65M  
 5: AA22-10A65M  
 6: AA42-10A65M  
 7: AA22-20A65M  
 8: AA42-20A65M

Ball Screw Models  
Speed and Current vs. Load

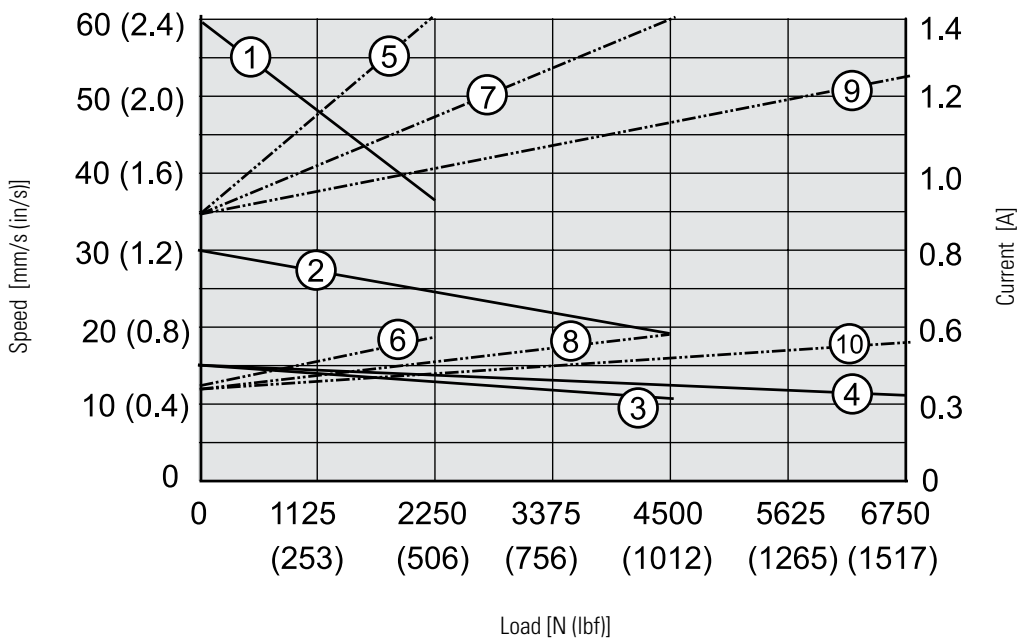

- Speed  
 1: AAxx-05B65M  
 2: AAxx-10B65M  
 3: AAxx-20B65M  
 4: AAxx-21B65M

- Current  
 5: AA22-05B65M  
 6: AA42-05B65M  
 7: AA22-10(20)B65M  
 8: AA42-10(20)B65M  
 9: AA22-21B65M  
 10: AA42-210B65M

# Electrak® LA24 – Ordering Key

## Ordering Key

1	2	3	4	5	6	7	8
<b>AA12-</b>	<b>05A65M</b>	<b>10</b>	<b>M0</b>	<b>N</b>	<b>A</b>	<b>F</b>	<b>M</b>

### 1. Model and input voltage

AA22 = Electrak LA24, 1 × 230 Vac  
AA42 = Electrak LA24, 3 × 400 Vac

### 2. Dynamic load capacity, screw type, maximum speed

05A65M = 1100 N, acme, 54 mm/s  
10A65M = 2250 N, acme, 30 mm/s  
20A65M = 2250 N, acme, 15 mm/s  
05B65M = 2250 N, ball, 61 mm/s  
10B65M = 4500 N, ball, 30 mm/s  
20B65M = 4500 N, ball, 15 mm/s  
21B65M = 6800 N, ball, 15 mm/s

### 3. Ordering stroke length

05 = 50 mm  
10 = 100 mm  
15 = 150 mm  
20 = 200 mm  
25 = 250 mm  
30 = 300 mm  
35 = 350 mm  
40 = 400 mm  
45 = 450 mm  
50 = 500 mm  
55 = 550 mm  
60 = 600 mm

### 4. Rear / front adapter hole position <sup>(1)</sup>

M0 = both adapters at 0° (standard position)  
M1 = rear adapter at 30°, front at 0°  
M2 = rear adapter at 60°, front at 0°  
M3 = rear adapter at 90°, front at 0°  
M4 = rear adapter at 120°, front at 0°  
M5 = rear adapter at 150°, front at 0°  
MF = rear and front adapter at 90°

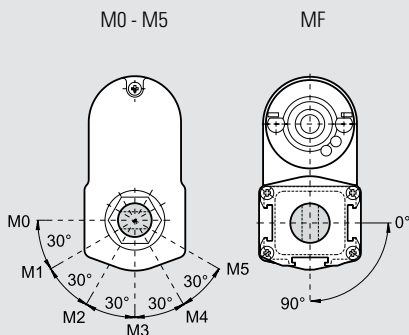

### 5. Options

N = no option  
B = anti-coast brake <sup>(2)</sup>  
NPO = potentiometer  
NHW = manual override <sup>(1)</sup>  
BPO = anti-coast brake and potentiometer <sup>(2)</sup>  
BHW = anti-coast brake and manual override <sup>(2)</sup>

Dimensions for manual override option

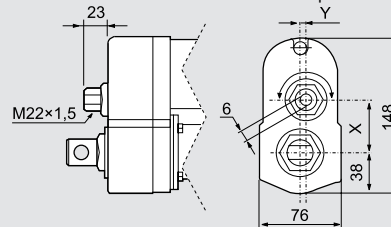

Model	X	Y
DAxx05A(B)65-	49.6	0.0
DAxx10A(B)65-	43.3	5.2
DAxx20(21)A(B)65-	38.9	0.0

### 6. Connector option

D = no connector (flying leads)

### 7. Front adapter option

E = cross hole for 0.5 inch pin  
F = forked cross hole for 0.5 inch pin  
G = 0.5 inch female thread  
M = cross hole for 12 mm pin  
N = forked cross hole for 12 mm pin  
P = 12 mm female thread

### 8. Rear adapter option

E = cross hole for 0.5 inch pin  
F = forked cross hole for 0.5 inch pin  
M = cross hole for 12 mm pin  
N = forked cross hole for 12 mm pin

(1) Only adapter position M0 possible with option manual override.

(2) Ball screw versions must always be ordered with anti-coast brake while acme versions can be ordered with or without.

# Electrak<sup>®</sup> LA24 – Electrical Connections

## Input Voltage 230 Vac

Actuator supply voltage AA22	[Vac]	1 × 230
---------------------------------	-------	---------

### No anti-coast brake

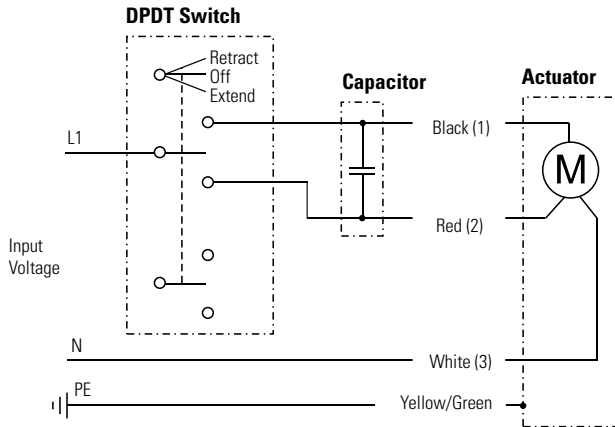

### With anti-coast brake

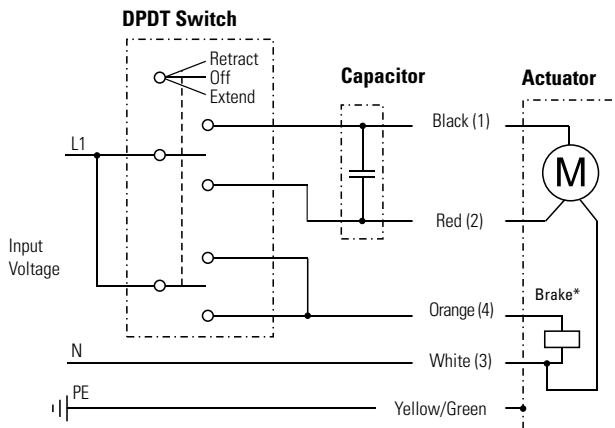

Leads can be either color or number marked. To be able to run the actuator, a 10  $\mu$ F capacitor must be connected between black (1) and red (2) leads. See page 72 for ordering of capacitors. Connect black (1) lead to L1 and white (3) lead to N (neutral) to retract the actuator. Change L1 from lead black (1) to lead red (2) to extend the actuator. If the actuator has an anti-coast brake\*, it must be released during motion, which is done by connecting orange (4) lead to L1.

## Input Voltage 400 Vac

Actuator supply voltage AA42x	[Vac]	3 × 400
----------------------------------	-------	---------

### No anti-coast brake

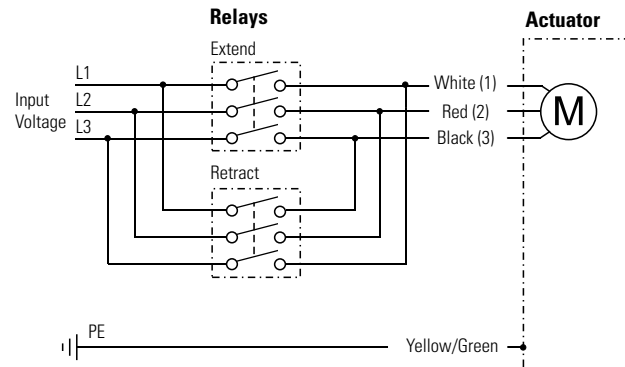

### With anti-coast brake

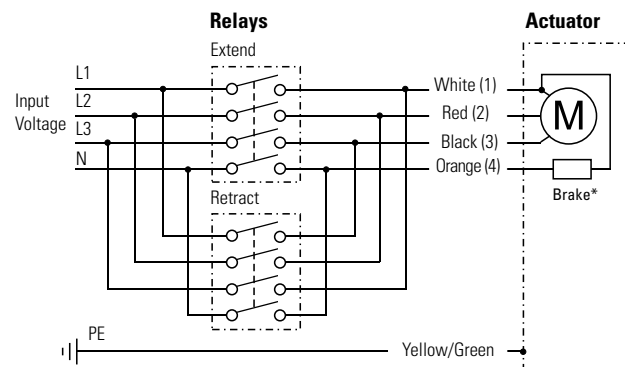

Leads can be either color or number marked. Connect white (1) lead to L1, red (2) lead to L2 and black (3) lead to L3 to extend the actuator. Change the places of white (2) lead and black (3) to retract the actuator. If the actuator has an anti-coast brake\*, it must be released during motion, which is done by connecting orange (4) lead to N (neutral).

# Electrak® LA24 – Electrical Connections

## Input Voltage 230 Vac + Option Potentiometer

Actuator supply voltage AA22	[Vac]	1 × 230
Potentiometer type		wire-wound
Potentiometer max. input voltage	[Vdc]	32
Potentiometer max. power	[W]	2
Potentiometer linearity	[%]	± 0.25
Potentiometer output resolution 50 - 255 mm stroke 256 - 510 mm stroke 511 - 600 mm stroke	[ohm/mm]	39 20 10

Leads can be either color or number marked. To be able to run the actuator, a 10 µF capacitor must be connected between black (1) and red (2) leads. See page 72 for ordering of capacitors. Connect black (1) lead to L1 and white (3) lead to N (neutral) to retract the actuator. Change L1 from lead black (1) to lead red (2) to extend the actuator. If the actuator has an anti-coast brake\*, it must be released during motion, which is done by connecting orange (4) lead to L1. The potentiometer output cable has 0 ohm between gray and yellow leads when the actuator is fully extended.

### No anti-coast brake

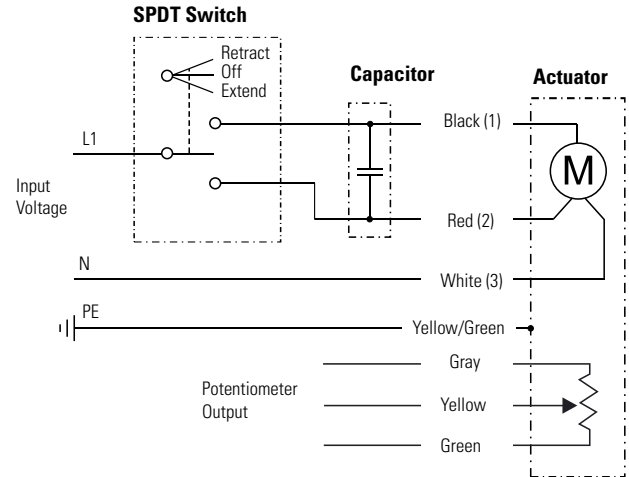

### With anti-coast brake

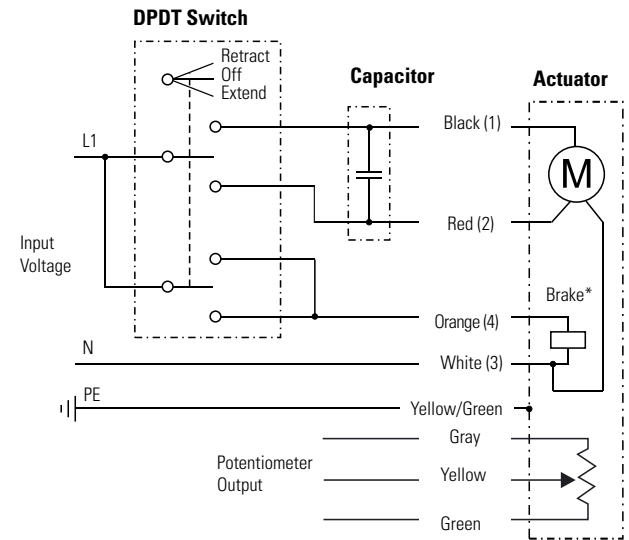

# Electrak<sup>®</sup> LA24 – Electrical Connections

Input Voltage 400 Vac + Option Potentiometer		
Actuator supply voltage AA42	[Vac]	3 × 400
Potentiometer type		wire-wound
Potentiometer max. input voltage	[Vdc]	32
Potentiometer max. power	[W]	2
Potentiometer linearity	[%]	± 0.25
Potentiometer output resolution	[ohm/mm]	
50 - 255 mm stroke		39
256 - 510 mm stroke		20
511 - 600 mm stroke		10

Leads can be either color or number marked. Connect white (1) lead to L1, red (2) lead to L2 and black (3) lead to L3 to extend the actuator. Change the places of white (2) lead and black (3) to retract the actuator. If the actuator have an anti-coast brake\*, it must be released during motion, which is done by connecting orange (4) lead to N (neutral). The potentiometer output cable has 0 ohm between gray and yellow leads when the actuator is fully extended.

## No anti-coast brake

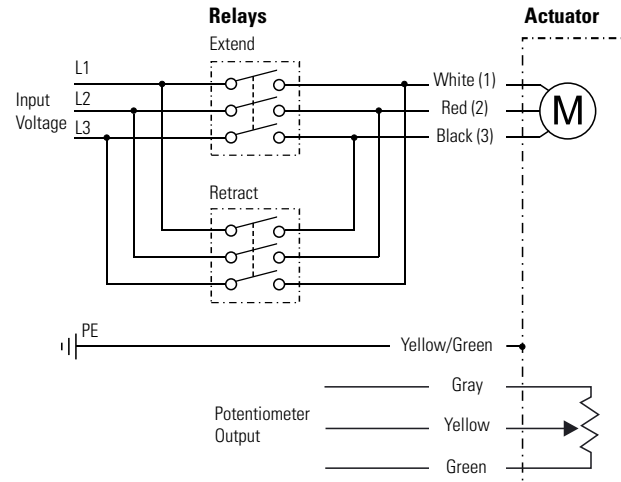

## With anti-coast brake

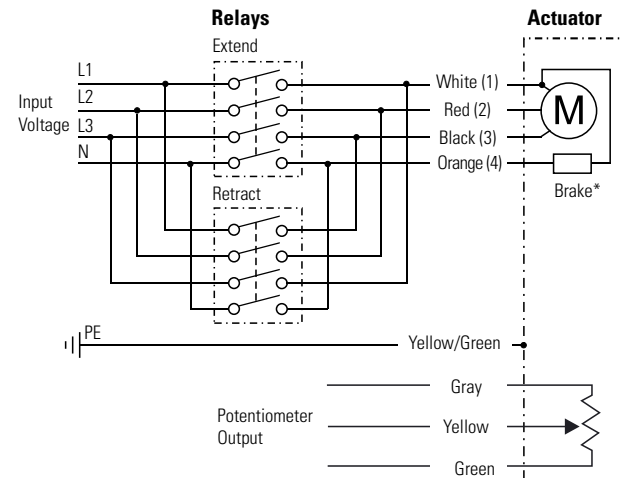

# Electrak® LA24 – Accessories

## Capacitor Kits

Designation	Actuator Supply Voltage	Part Number
Capacitor kit	230 Vac	9200-448-003

All 230 Vac actuators require a capacitor to be wired between the windings to run. The capacitor is bought separately and mounted externally by the customer.

## Mounting Pin Kits

Designation	A [mm (in)]	Part Number
Mounting pins (pair)	12 (0.47)	D603 023

The mounting pins are used in the rear and front adapter holes of the actuator. The pins have a groove in each end so that it can be secured with snap rings.

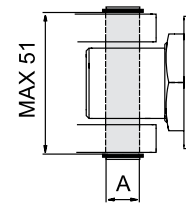

Dimensions  
mm

## Magnetic Sensor

Designation	Contact Type	Part Number
Magnetic sensor	normally open	D535 070
Magnetic sensor	normally closed	D535 071
Magnetic sensor	changing	D535 073

## Specifications

Parameter		D535 070 D535 071	D535 073
Maximum power	[W]	10	10
Maximum voltage	[Vdc]	100	100
Maximum current	[A]	0,5	0,5
Maximum contact resistance	[ohm]	0,2	0,2
Lead cross section	[mm <sup>2</sup> ]	2 × 0,14	3 × 0,14
Cable length	[mm]	3000	3000
Protection class		IP67	IP67

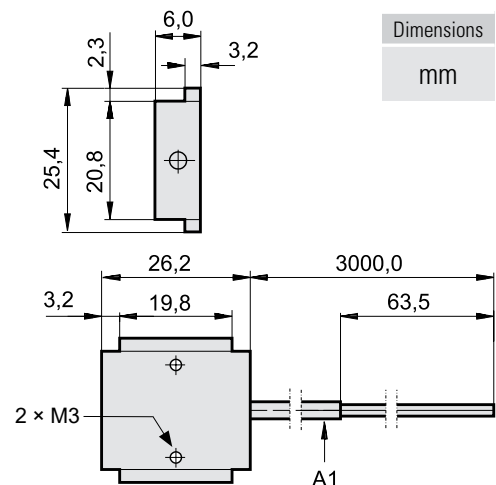

Dimensions  
mm

A1: cable

The magnetic sensor fits in to the T-slot running along three sides of the cover tube. The cable is moulded into the sensor.



# Electrak® LA24 – Accessories

## Mounting Pin Bracket Kits

Designation	Part Number
Mounting pin brackets (pair)	D603 029

The mounting pin brackets are used to attach the front and rear adapter via a pair of mounting pins to the objects to which it is mounted. Note! one pair of brackets is needed per adapter as there must be a bracket on each side of the adapter.

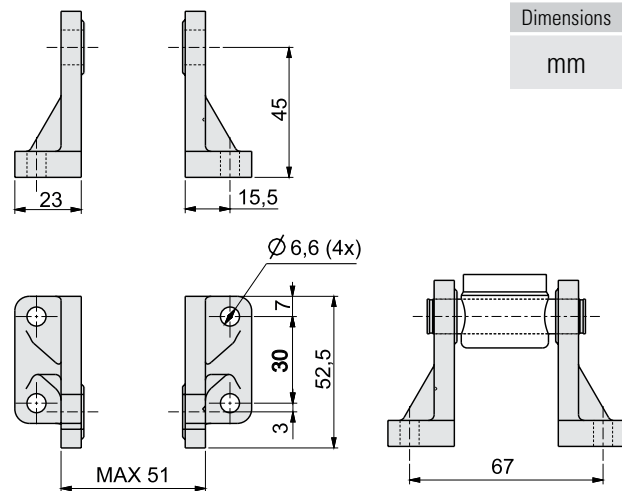

Dimensions  
mm

## Trunnion Mounting Kits

Designation	Part Number
Trunnions (pair)	D603 022
Trunnion brackets (pair)	D603 030

The trunnions can be mounted to the T-slot running along the right and left side of the cover tube.

### Trunnions

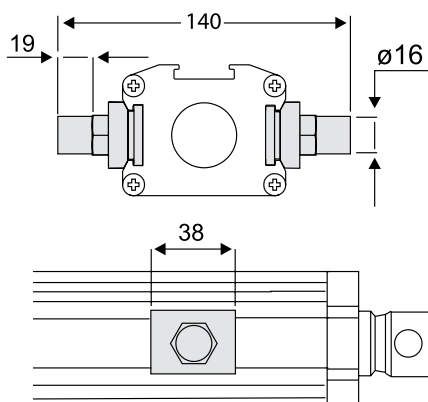

Dimensions  
mm

### Trunnion Brackets

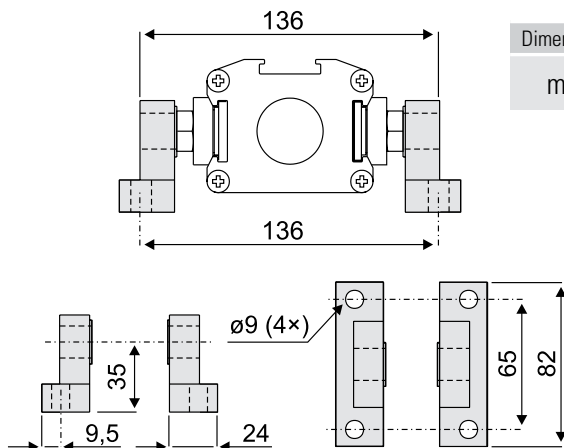

Dimensions  
mm

# Electrak® PPA – Technical Features



## Standard Features

- Strong and versatile heavy-duty actuator
- High duty cycle
- 12, 24, 36 or 90 Vdc as standard input voltages
- Highly efficient ball screw drive system
- Static load up to 13350 N (3000 lbf)
- Dynamic load up to 6670 N (1500 lbf)
- Stroke up to 36 inch
- Overload clutch for mid and end of stroke protection
- Motor with thermal switch
- Maintenance free

## General Specifications

Screw type	ball
Nut type	ball nut
Manual override	no
Anti-rotation	no
Static load holding brake	yes
Safety features	overload clutch motor auto reset thermal switch
Electrical connections	flying leads
Compliances standard	–
optional	CE <sup>(1, 2)</sup>

(1) Actuators used in the EU must be in compliance with CE

(2) 90 Vdc model not CE compliant

## Optional Mechanical Features

Protective bellows

## Optional Electrical Features

Potentiometer feedback

Encoder feedback

End of stroke limit switches

## Accessories

Rear clevis mounting kit

Tube mounting kits

## Compatible Controls

Contact customer support at [www.thomsonlinear.com/cs](http://www.thomsonlinear.com/cs)

# Electrak<sup>®</sup> PPA – Technical Specifications

Mechanical Specifications		
Max. static load <sup>(1)</sup>	[N (lbf)]	13350 (3000)
Max. dynamic load (Fx) PPAxx-18B65 PPAxx-58B65	[N (lbf)]	3330 (750) 6670 (1500)
Speed @ no load/max. load PPAxx-18B65 PPAxx-58B65	[mm/s (in/s)]	32/28 (1.26/1.10) 12/9 (0.49/0.37)
Min. ordering stroke (S) length	[in]	4
Max. ordering stroke (S) length <sup>(2)</sup>	[in]	36
Standard stroke lengths	[in]	4, 8, 12, 18, 24, 36
Operating temperature limits	[°C (F)]	-25 – 65 (- 15 – 150)
Full load duty cycle @ 25 °C (77 °F)	[%]	30
End play, maximum	[mm (in)]	1.0 (0.04)
Restraining torque PPAxx-18B65 PPAxx-58B65	[Nm (lbf-in)]	11 (100) 22 (200)
Protection class - static		IP54

(1) Max. static load at fully retracted stroke

Electrical Specifications		
Available input voltages <sup>(1)</sup>	[Vdc]	12, 24, 36, 90
Input voltage tolerance	[%]	± 10
Current draw @ no load/max. load <sup>(2)</sup> PPA12-18B65 PPA12-58B65 PPA24-18B65 PPA24-58B65 PPA36-18B65 PPA36-58B65	[A]	7.5/22.0 7.5/13.5 3.0/12.0 3.0/12.0 4.5/8.0 3.0/6.0
Motor leads length	[mm (in)]	420 (16.5)
Motor leads cross section	[mm <sup>2</sup> (AWG)]	2 (14)
Connection of electrical options <sup>(3)</sup>		terminals

(1) For other input voltages - contact customer support

(2) For current draw for 90 Vdc input voltage models - contact customer support

(3) Potentiometer, encoder or end of stroke limit switches

# Electrak® PPA – Dimensions

Dimensions	Projection
mm [inch]	

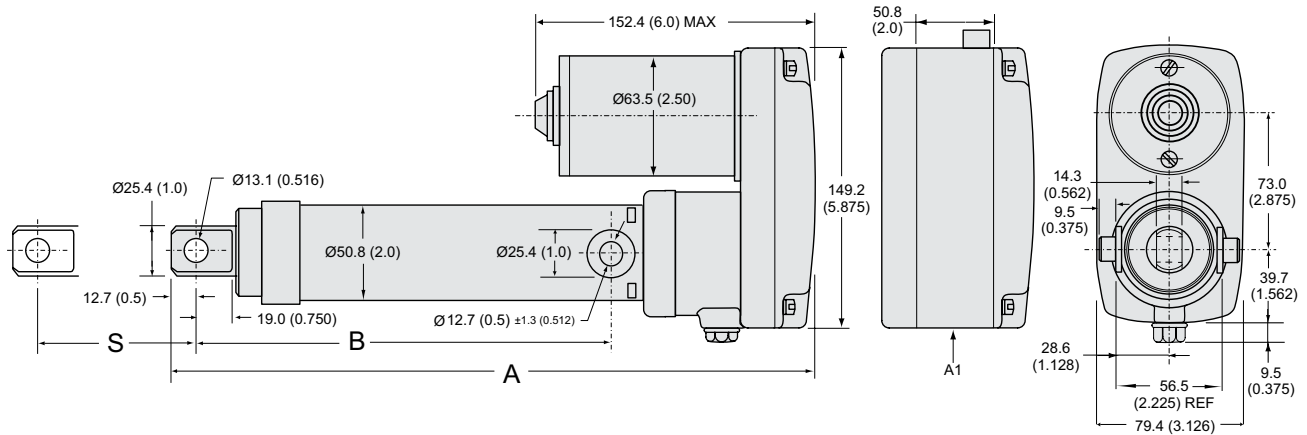

S: stroke  
A: retracted length

B: retracted length to trunnions  
A1: housing dimensions for limit switch, encoder or potentiometer options

## Stroke, Retracted Length and Weight Relationships

Ordering stroke (S)	[in (mm)]	4 (101.5)	8 (203.2)	12 (304.8)	18 (457.2)	24 (609.6)	36 (914.4)
Retracted length without option (A)	[mm]	348.0	449.6	551.2	754.4	906.8	1211.6
	[in]	13.7	17.7	21.7	29.7	35.7	47.7
Retracted length with potentiometer, encoder or limit switch option (A)	[mm]	398.8	500.4	602.0	805.2	957.6	1262.4
	[in]	15.7	19.7	23.7	31.7	37.7	49.7
Retracted length to trunnions (B)	[mm]	223.5	352.1	426.7	629.9	782.3	1087.1
	[in]	8.8	12.8	16.8	24.8	30.8	42.8
Weight	[kg]	4.5	5.3	6.0	7.2	8.4	10.8
	[lbf]	10.0	11.6	13.3	15.9	18.5	23.8
Add on weight for potentiometer, encoder or limit switch options	[kg]	0.5					
	[lbf]	1.1					

# Electrak® PPA – Performance Diagrams

Speed and Current vs. Load

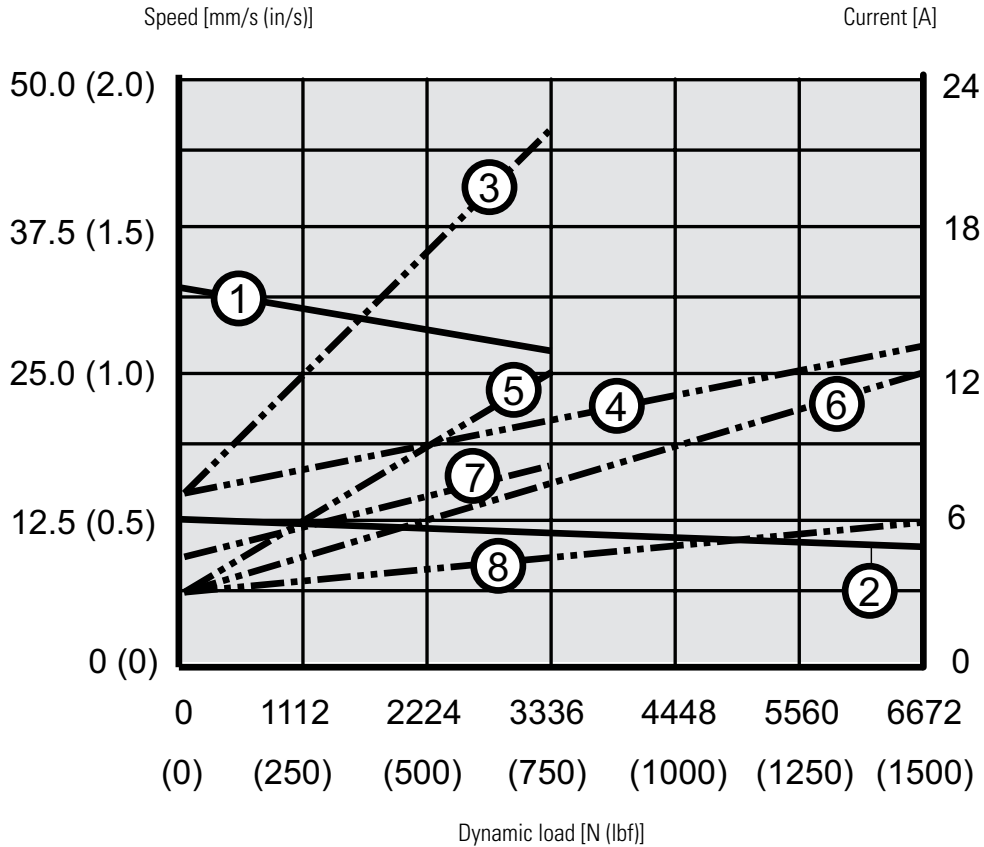

Speed

- 1: PPAxx-18B65 (3330 N (750 lbf))
- 2: PPAxx-58B65 (6670 N (1500 lbf))

Current

- 3: PPA12-18B65 (12 Vdc, 3330 N (750 lbf))
- 4: PPA12-58B65 (12 Vdc, 6670 N (1500 lbf))
- 5: PPA24-18B65 (24 Vdc, 3330 N (750 lbf))
- 6: PPA24-58B65 (24 Vdc, 6670 N (1500 lbf))
- 7: PPA36-18B65 (36 Vdc, 3330 N (750 lbf))
- 8: PPA36-58B65 (36 Vdc, 6670 N (1500 lbf))

# Electrak® PPA – Ordering Key

Ordering Key					
1	2	3	4	5	6
<b>PPA12-</b>	<b>58B65-</b>	<b>08</b>	<b>N-</b>	<b>LS</b>	<b>X</b>
<p><b>1. Model and input voltage</b>            PPA12 - = Electrak PPA DC, 12 Vdc            PPA24 - = Electrak PPA DC, 24 Vdc            PPA36 - = Electrak PPA DC, 36 Vdc            PPA90 - = Electrak PPA DC, 90 Vdc <sup>(1)</sup></p> <p><b>2. Dynamic load capacity</b>            18B65 - = 3330 N (750 lbf)            58B65 - = 6670 N (1500 lbf)</p> <p><b>3. Ordering stroke length</b>            04 = 4 inch (101.6 mm)            08 = 8 inch (203.2 mm)            12 = 12 inch (304.8 mm)            18 = 18 inch (457.2 mm)            24 = 24 inch (609.6 mm)            36 = 36 inch (914.4 mm)</p>			<p><b>4. Brake option</b>            N - = no brake option</p> <p><b>5. Feedback option</b>            XX = no feedback option            LS = end of stroke limit switches            PO = potentiometer <sup>(2)</sup>            HS = encoder            HL = encoder + end of stroke limit switches</p> <p><b>6. Bellows option</b>            X = no bellows            C = bellows</p> <p>(1) Not CE compliant.            (2) Potentiometer + end of stroke limit switches not possible.</p>		

# Electrak® PPA – Electrical Connections

## Without Option

Actuator supply voltage	[Vdc]	
PPA12		12
PPA24		24
PPA36		36
PPA90		90

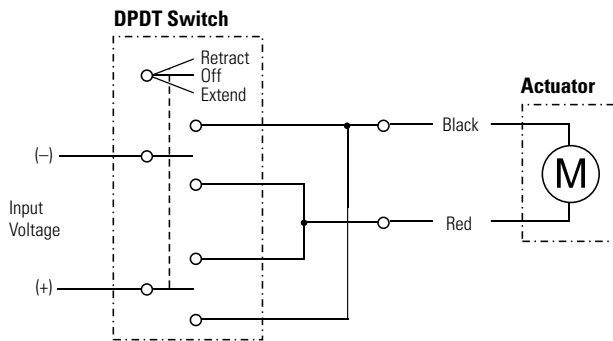

Connect the black lead to positive and red to negative to extend the actuator. Change polarity to retract the actuator.

## With Option End of Stroke Limit Switches

Actuator supply voltage	[Vdc]	
PPA12		12
PPA24		24
PPA36		36
PPA90		90
Limit switches max. voltage	[V]	250
Limit switches max. current	[A]	15.1

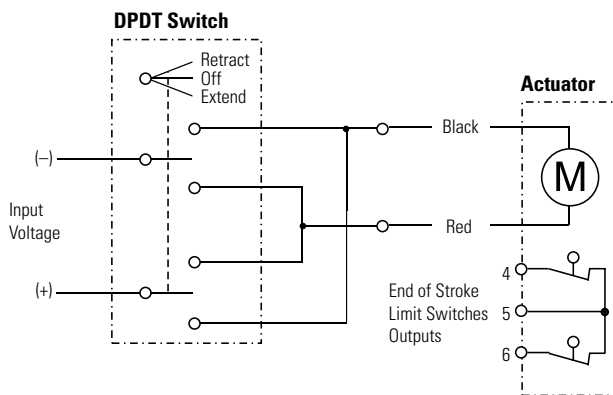

Connect the black lead to positive and red to negative to extend the actuator. Change polarity to retract the actuator. Limit switch outputs are on terminals 4 and 6, and they have a common voltage input on terminal 5.

## With Option Potentiometer

Actuator supply voltage	[Vdc]	
PPA12		12
PPA24		24
PPA36		36
PPA90		90
Potentiometer type		wire-wound
Potentiometer max. voltage	[Vdc]	32
Potentiometer max. power	[W]	2
Potentiometer linearity	[%]	± 5
Potentiometer output resolution	[ohm/mm]	
4 inch stroke		98
8 inch stroke		49
12 inch stroke		33
18 inch stroke		22
24 inch stroke		16
36 inch stroke		11

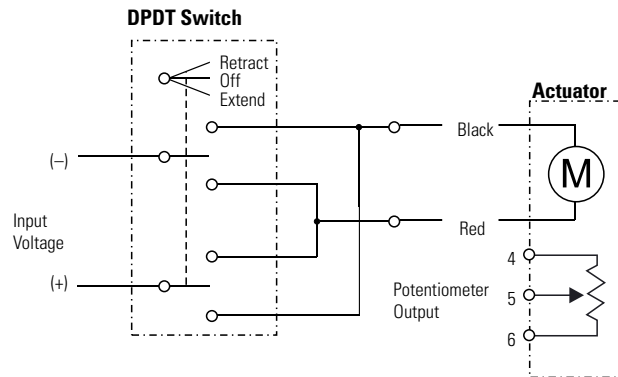

Connect the black lead to positive and red to negative to extend the actuator. Change polarity to retract the actuator. The potentiometer output has 0 ohm between terminal 4 and 5 when the actuator is fully retracted.

# Electrak® PPA – Electrical Connections

## With Option Encoder

Actuator supply voltage	[Vac]	
PPA12		12
PPA24		24
PPA36		36
PPA90		90
Encoder type		hall effect
Encoder input voltage	[Vdc]	4.5 - 12
Encoder output voltage levels low (logical zero), typical / max.	[Vdc]	0.1 / 0.25
Encoder resolution	[mm/pulse]	1.18
Number of encoder channels		1

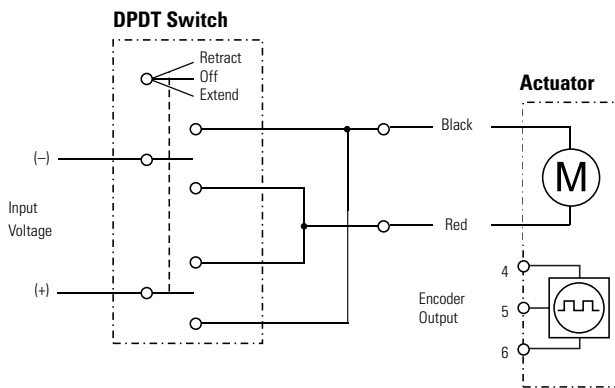

Connect the black lead to positive and red to negative to extend the actuator. Change polarity to retract the actuator. The encoder is supplied between terminals 4 and 6, and the pulse train signal is generated on terminal 5.

## With Option Encoder + End of Stroke Limit Switches

Actuator supply voltage	[Vac]	
PPA12		12
PPA24		24
PPA36		36
PPA90		90
Encoder type		hall effect
Encoder input voltage	[Vdc]	4.5 - 12
Encoder output voltage levels low (logical zero), typical / max.	[Vdc]	0.1 / 0.25
Encoder resolution	[mm/pulse]	1.18
Number of encoder channels		1
Limit switches max. voltage	[V]	250
Limit switches max. current	[A]	15.1

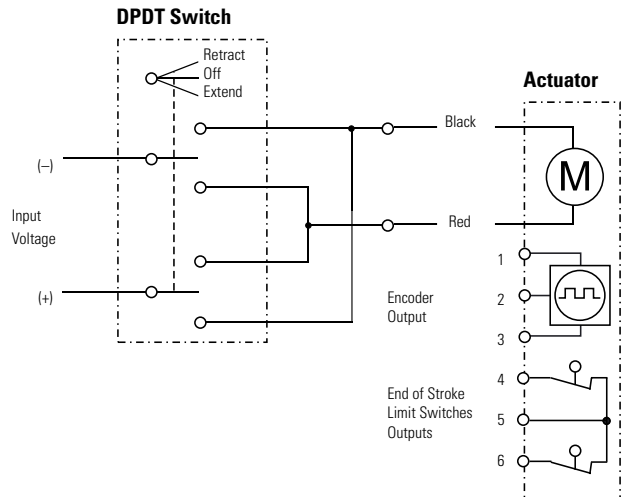

Connect the black lead to positive and red to negative to extend the actuator. Change polarity to retract the actuator. The encoder is supplied between terminals 1 and 3, and the pulse train signal is generated on terminal 2. Limit switch outputs are on terminals 4 and 6, and they have a common voltage input on terminal 5.



# Electrak® PPA – Accessories

## PPA Rear Clevis Mounting Kits

Designation	Compatible Actuators	Part Number
PPA rear clevis mounting kit type 1	Electrak PPA	7827320
PPA rear clevis mounting kit type 2	Electrak PPA	7824295

The rear clevis mounting kits are attached to the tube of an Electrak PPA actuator, allowing it to be mounted clevis to clevis style.

### PPA Rear Clevis Mounting Kit - Type 1

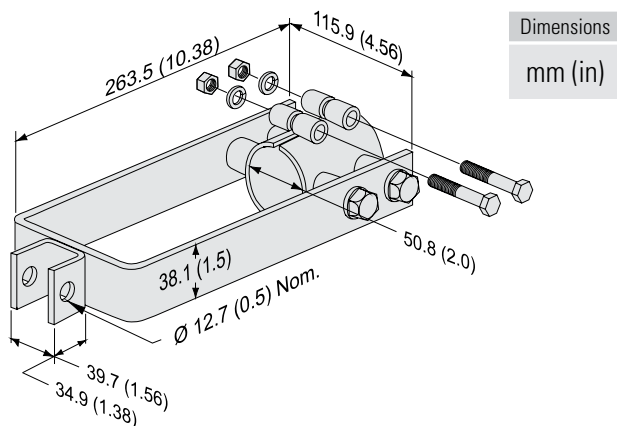

### PPA Rear Clevis Mounting Kit - Type 2

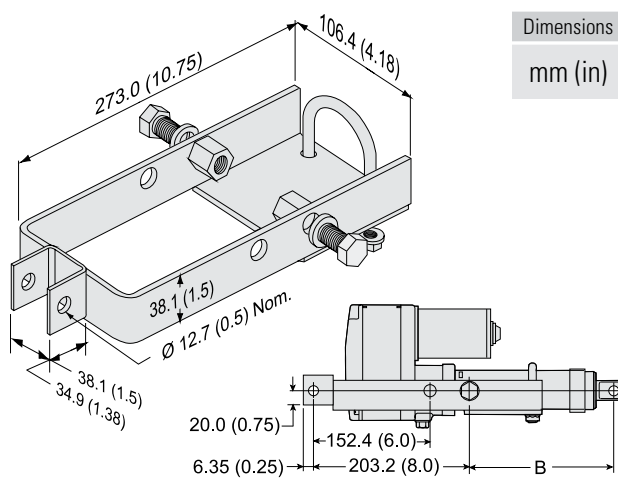

B: retracted length to trunnion, also see product pages.

## PPA Tube Mounting Kits

Designation	Compatible Actuators	Part Number
Electrak PPA tube mount - light duty 3330 N	Electrak PPA	7822520
Electrak PPA tube mount - heavy-duty 6670 N	Electrak PPA	7821783

The tube mounting kits work as a clamp that is mounted at any desired position along the actuator tube. Trunnion pins for the tube mount clamp are supplied and mounted by the customer.

### Electrak PPA Tube Mount - Light Duty 3330 N (750 lbf)

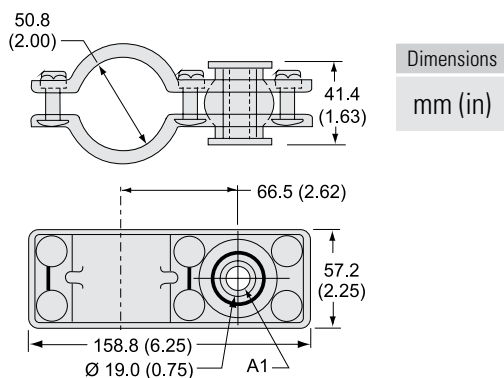

A1: hole diameter 12.7 mm (0.5 in) with bushing.

### Electrak PPA Tube Mount - Heavy-duty 6670 N (1500 lbf)

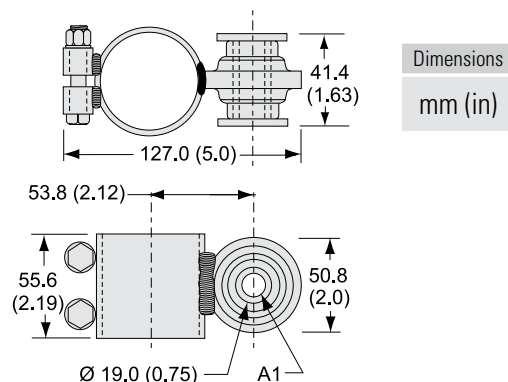

A1: hole diameter 12.7 mm (0.5 in) with bushing.

## Max Jac® – Technical Features



### Standard Features

- Designed for industrial applications
- Rugged aluminium housing with IP69K
- High efficiency
- Long life
- Hard coat anodizing for high corrosion resistance
- Virtually maintenance free
- Worm or ball screw models
- Non-contact analog position feedback signal

### General Specifications

Screw type	worm or ball
Nut type	lead or ball
Manual override	no
Anti-rotation	no
Static load holding brake worm screw models ball screw models	no (self-locking) no
Safety features	none
Electrical connections	flying leads or cable with AMP Superseal connector
Compliances	CE

### Optional Electrical Features

Digital feedback

### Compatible Controls

Contact customer support at [www.thomsonlinear.com/cs](http://www.thomsonlinear.com/cs)

# Max Jac<sup>®</sup> – Technical Specifications

Mechanical Specifications		
Max. static load <sup>(1)</sup> MXxxW (worm screw) MXxxB (ball screw) <sup>(2)</sup>	[N (lbf)]	2000 (450) 100 - 350 (22 - 79)
Max. dynamic load (Fx) MXxxW (worm screw) MXxxB (ball screw)	[N (lbf)]	500 (112) 800 (180)
Speed @ no load/max. load MXxxW (worm screw) MXxxB (ball screw)	[mm/s (in/s)]	33 / 19 (1.3 / 0.75) 60 / 30 (2.4 / 1.2)
Min. ordering stroke (S) length	[mm]	50
Max. ordering stroke (S) length MXxxW (worm screw) MXxxB (ball screw)	[mm]	200 300
Ordering stroke length increments	[mm]	50
Operating temperature limits	[°C (F)]	-40 – 85 (-40 – 185)
Duty cycle, maximum <sup>(3)</sup> MXxxW (worm screw) MXxxB (ball screw)	[%]	load dependent load dependent
End play, maximum	[mm (in)]	0.3 (0.012)
Restraining torque	[Nm (lbf-in)]	2 (1.48)
Protection class - static		IP66/IP69K
Salt spray resistance	[h]	500

(1) Max. static load at fully retracted stroke

(2) The static force (i.e. the back-driving force) for a ball screw unit varies and is dependent on the number of cycles it has been running and at which loads.

(3) See "Duty cycle vs. load" chart in the Glossary section.

Electrical Specifications		
Available input voltages	[Vdc]	12, 24
Input voltage tolerance	[%]	+15 / -10
Current draw @ no load/max. load MX12W (12 Vdc input, worm screw) MX24W (24 Vdc input, worm screw) MX12B (12 Vdc input, ball screw) MX24B (24 Vdc input, ball screw)	[A]	1.2/8.0 0.8/3.8 1.1/7.4 0.7/3.5
Inrush/stall current @ max. load MX12W (12 Vdc input, worm screw) MX24W (24 Vdc input, worm screw) MX12B (12 Vdc input, ball screw) MX24B (24 Vdc input, ball screw)	[A]	18.0 9.0 18.0 9.0
Cable lengths, standard <sup>(1)</sup>	[mm (in)]	300 (12), 1600 (63)
Cable diameter <sup>(1)</sup>	[mm (in)]	6.2 (0.244)
Cable leads cross section <sup>(1)</sup>	[mm <sup>2</sup> (AWG)]	1 (18)

(1) The same cable is used both for the input voltage and the feedback signals.

# Max Jac<sup>®</sup> – Dimensions

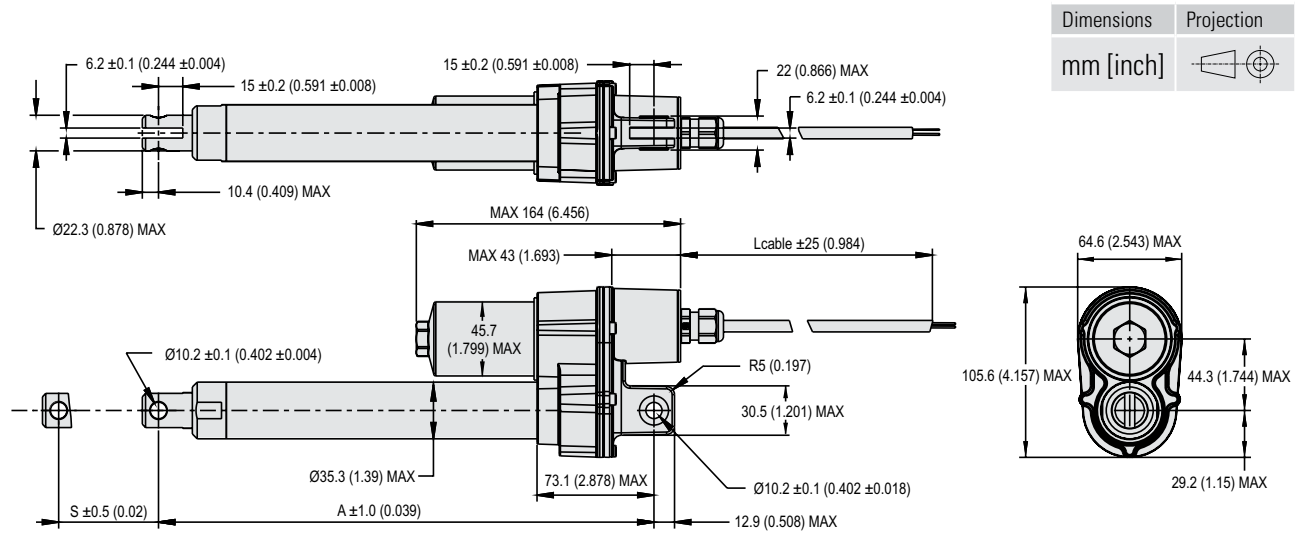

## Stroke, Retracted Length and Weight Relationships

Ordering stroke (S)	[mm]	50	100	150	200	250*	300*
Retracted length (A)	[mm]	206	256	306	356	406	456
	[in]	8.11	10.08	12.05	14.02	15.98	17.95
Weight	[kg]	1.5	1.7	1.9	2.1	2.2	2.4
	[lbf]	3.3	3.8	4.2	4.6	4.8	5.3

\* Stroke not possible for MSxxW1 (worm screw) models.

# Max Jac® – Performance Diagrams

## Speed and Current vs. Load

Worm Screw Models (MXxxW)

Ball Screw Models (MXxxB)

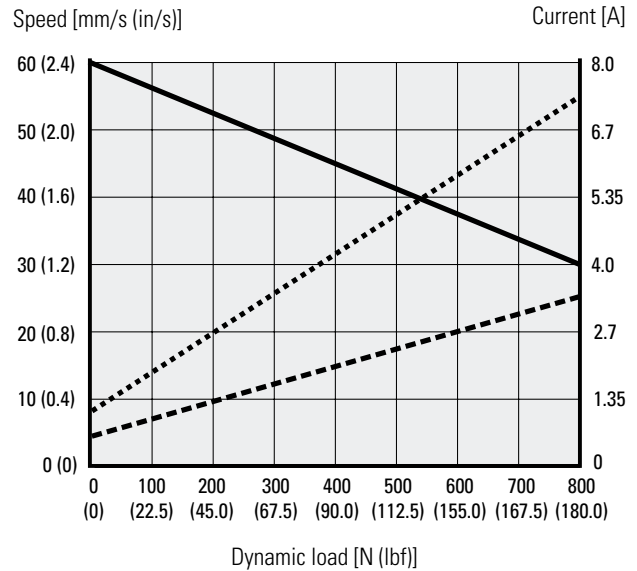
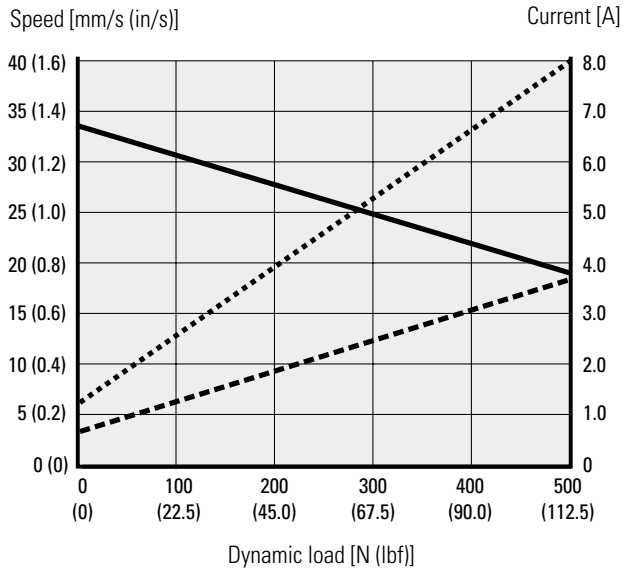

Speed ——— Current @ 12 Vdc ..... Current @ 24 Vdc - - - -

## Duty Cycle vs. Load

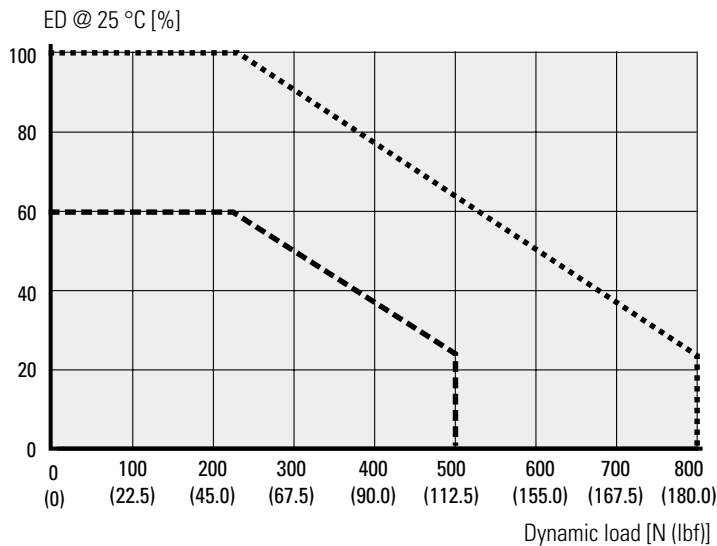

Worm Screw Models (MXxxW) - - - - Ball Screw Models (MXxxB) .....

# Max Jac<sup>®</sup> – Ordering Key

Ordering Key				
1	2	3	4	5
MX12	W1	M05	P	0
<p><b>1. Model and input voltage</b> MX12 = Max Jac, 12 Vdc MX24 = Max Jac, 24 Vdc</p> <p><b>2. Dynamic load capacity, screw type and maximum speed</b> W1 = 500 N (112 lbf), worm screw, 35 mm/s (1.38 in/s) B8 = 800 N (180 lbf, ball screw, 55 mm/s (2.17 in/s)</p> <p><b>3. Ordering stroke length</b> M05 = 50 mm (1.969 in) M10 = 100 mm (3.937 in) M15 = 150 mm (5.906 in) M20 = 200 mm (7.874 in) M25 = 250 mm (9.843 in)<sup>(1)</sup> M30 = 300 mm (11.811 in)<sup>(1)</sup></p>		<p><b>4. Options</b> P = analog feedback (standard) E = digital encoder feedback</p> <p><b>5. Connector option</b> 0 = 300 mm (12 in) long flying leads 1 = 300 mm (12 in) long cable and AMP Superseal connector 2 = 1600 mm (63 in) long cable and AMP Superseal connector</p> <p>(1) Stroke not possible for MSxxW1 (worm screw) models.</p>		

# Max Jac® – Electrical Connections

## Option Analog Feedback

Actuator supply voltage	[Vdc]	12 24
MX12		
MX24		
Analog feedback type		non-contact
Analog feedback input voltage	[Vdc]	5
Analog feedback output voltage	[Vdc]	0.5 - 4.5
Analog feedback output linearity	[%]	± 1

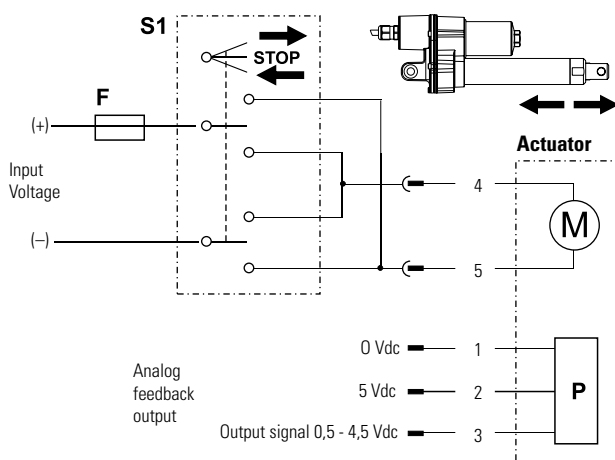

- M Actuator motor
- S1 Double pole double throw (DPDT) switch
- F Fuse
- P Analog feedback device

Connect lead 5 to positive and 4 to negative to extend the actuator. Change polarity to retract the actuator. The analog feedback device is supplied between leads 1 and 2, and the output signal is generated on lead 3.

Keep in mind that the actuator voltage must be switched off when reaching the ends of stroke or due to a mid-stroke overload to avoid causing damage to the actuator.

## Option Encoder Feedback

Actuator supply voltage	[Vdc]	12 24
MX12		
MX24		
Encoder type		incremental
Number of encoder channels		2
Encoder input voltage	[Vdc]	5
Encoder output resolution	[pulse/mm]	9.86 5.84
MX12W		
MX12B		

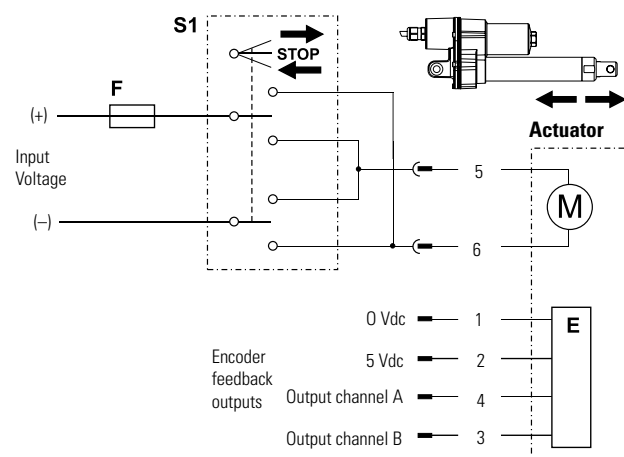

- M Actuator motor
- S1 Double pole double throw (DPDT) switch
- F Fuse
- E Encoder feedback device

Connect lead 6 to positive and 5 to negative to extend the actuator. Change polarity to retract the actuator. The encoder feedback device is supplied between leads 1 and 2, and the output signal train from channel A is generated on lead 4 and channel B on lead 3.

Keep in mind that the actuator voltage must be switched off when reaching the ends of stroke or due to a mid-stroke overload to avoid causing damage to the actuator.

# Electrak® 050 – Technical Features



## Standard Features

- Designed for office or medical applications
- Small, quiet and lightweight
- Short retracted length
- Low cost
- Durable and corrosion free plastic housing
- Color molded into the plastic, no painting required
- Maintenance free
- Internally restrained extension tube
- Estimated life is minimum 40000 cycles

## General Specifications

Screw type	worm
Nut type	lead
Manual override	no
Anti-rotation	yes
Static load holding brake	no (self-locking)
Safety features	internal limit switches overload clutch auto reset thermal switch
Electrical connections	cable with flying leads or connector
Compliances	CE

## Optional Mechanical Features

Cross hole orientation

## Optional Electrical Features

End of stroke limit switches with dynamic braking

Potentiometer feedback



# Electrak<sup>®</sup> 050 – Technical Specifications

Mechanical Specifications		
Max. static load <sup>(1)</sup> DExx17W41 DExx17W42 DExx17W44	[N (lbf)]	1020 (224) 550 (120) 280 (60)
Max. dynamic load (Fx) DExx17W41 DExx17W42 DExx17W44	[N (lbf)]	<b>510 (112)</b> <b>275 (60)</b> <b>140 (30)</b>
Speed @ no load/max. load	[mm/s (in/s)]	12/9 (0.5 /0.35) 24/18 (0.9/0.7) 48/37 (1.9/1.5)
Min. ordering stroke (S) length	[mm]	25
Max. ordering stroke (S) length	[mm]	200
Ordering stroke length increments	[in]	25
Operating temperature limits	[°C (F)]	-30 – 80 (-22 – 176)
Full load duty cycle @ 20 °C (?? °F)	[%]	25
End play, maximum	[mm (in)]	1.5 (0.06)
Restraining torque	[Nm (lbf-in)]	0
Protection class - static		IP56
Salt spray resistance	[h]	96

Electrical Specifications		
Available input voltages	[Vdc]	12, 24, 36
Input voltage tolerance	[%]	± 10
Current draw @ no load/max. load <sup>(1)</sup> DE12-17W41 DE12-17W42 DE12-17W44 DE24-17W41 DE24-17W42 DE24-17W44	[A]	1.4/3.8 0.7/1.9 1.2/3.8 0.6/1.8 1.4/3.8 0.7/1.9
Cable lengths, standard <sup>(2)</sup>	[mm (in)]	150 (6.0)
Cable diameter	[mm (in)]	13 (0.5)
Cable leads cross section	[mm <sup>2</sup> (AWG)]	1 (18)

(1) For current draw for 36 Vdc input voltage models - contact customer support.

(2) The same cable is used both for the input voltage and the feedback signals.

# Electrak® 050 – Dimensions

Dimensions	Projection
mm [inch]	

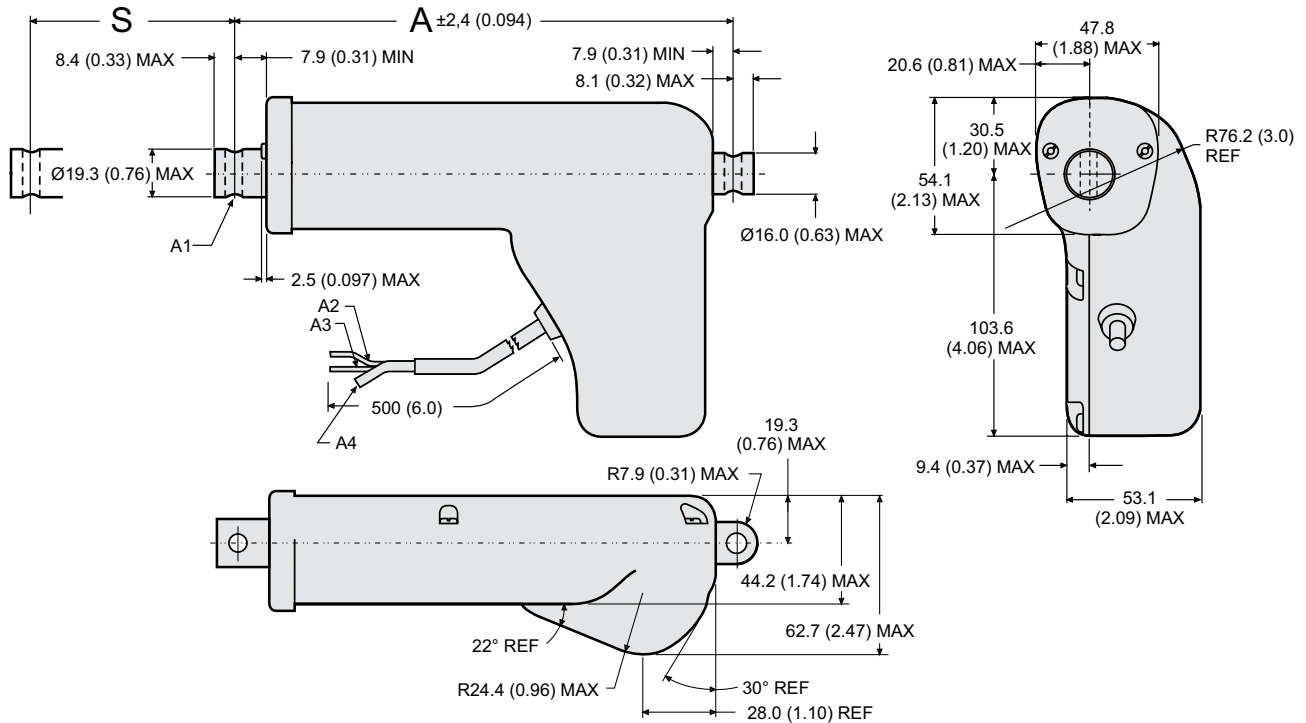

Note: see 3D models for all available adapter options

S: stroke (tolerances: 17W41 =  $\pm 3.23$  mm (0.127 in), 17W42 =  $\pm 4.25$  mm (0.167 in), 17W44 =  $\pm 5.26$  mm (0.207 in))

A: retracted length

A1: Shown are  $\text{Ø} 6$  mm  $+0.15/-0$  (0.236 in  $+0.006/-0$ ) mounting cross holes (2  $\times$ ) in standard position.

A2: red lead

A3: yellow lead

A4: vent tube  $\text{Ø} 3$  mm (0.188 in)

## Stroke, Retracted Length and Weight Relationships

Ordering stroke (S)	[in]	1	2	3	4	5	6	7	8
Retracted length (A)	[mm]	114.2	139.2	164.2	189.2	214.2	239.2	264.2	289.2
	[in]	4.496	5.480	6.465	7.449	8.433	9.417	10.402	11.386
Add on length for option 0.25 inch fork front adapter	[mm]	16.3							
	[in]	0.64							
Add on length for option potentiometer	[mm]	31.5							
	[in]	1.24							
Weight	[kg]	0.59	0.64	0.69	0.73	0.78	0.82	0.87	0.91
	[lbf]	1.30	1.41	1.52	1.61	1.72	1.81	1.92	2.01
Add on weight for option potentiometer	[kg]	0.10							
	[lbf]	0.22							

\* 8 inch stroke not possible with potentiometer (PO, MP, PF options)

# Electrak® 050 – Performance Diagrams

Speed and Current vs. Load

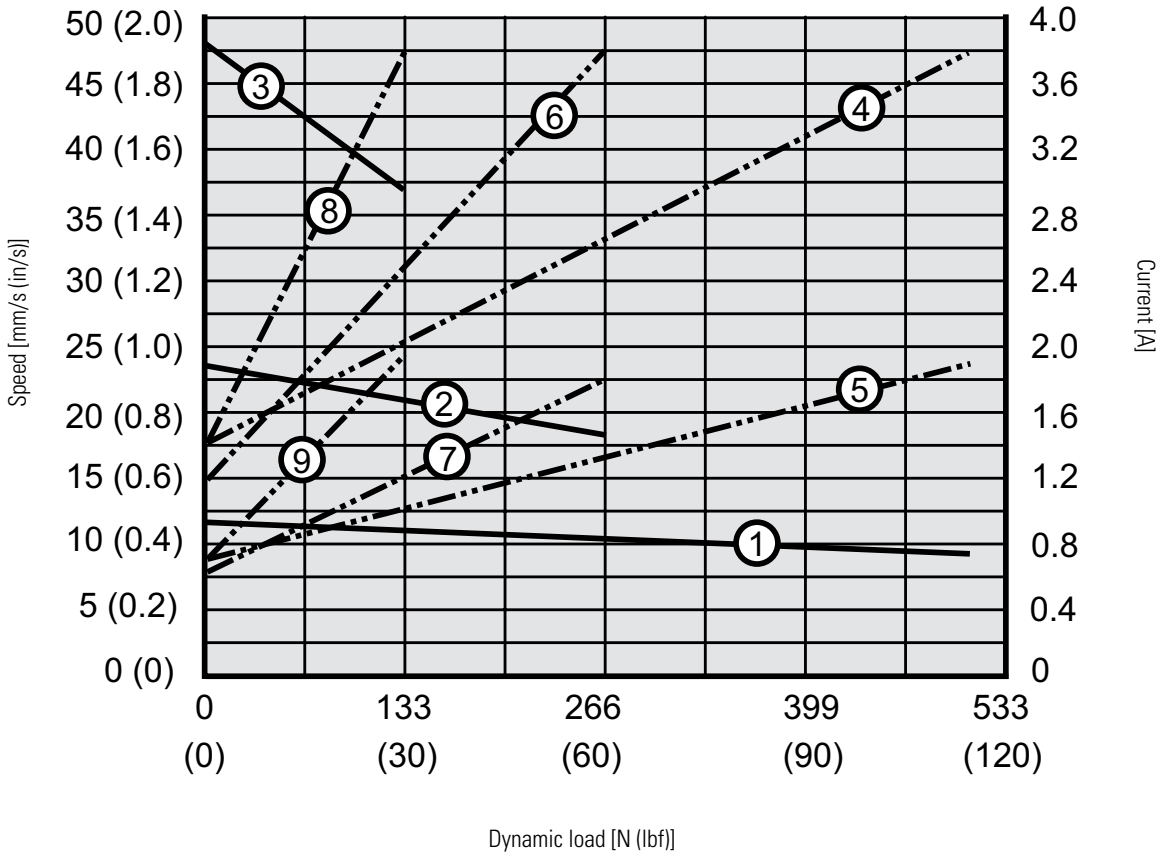

Speed

- 1: DExx-17W41 (510 N (112 lbf))
- 2: DExx-17W42 (275 N (60 lbf))
- 3: DExx-17W44 (140 N (30 lbf))

Current

- 4: DE12-17W41 (12 Vdc, 510 N (112 lbf))
- 5: DE24-17W41 (24 Vdc, 510 N (112 lbf))
- 6: DE12-17W42 (12 Vdc, 275 N (60 lbf))
- 7: DE24-17W42 (24 Vdc, 275 N (60 lbf))
- 8: DE12-17W44 (12 Vdc, 140 N (30 lbf))
- 9: DE24-17W44 (24 Vdc, 140 N (30 lbf))

# Electrak® 050 – Ordering Key

Ordering Key							
1	2	3	4	5	6	7	8
<b>DE12</b>	<b>17W41-</b>	<b>02</b>	<b>NN</b>	<b>HH</b>	<b>N</b>	<b>C</b>	<b>A</b>
<p><b>1. Model and input voltage</b> DE12 = Electrak 050, 12 Vdc DE24 = Electrak 050, 24 Vdc DE36 = Electrak 050, 36 Vdc</p> <p><b>2. Dynamic load capacity</b> 17W41 - = 510 N (112 lbf) 17W42 - = 275 N (60 lbf) 17W44 - = 140 N (30 lbf)</p> <p><b>3. Ordering stroke length</b> 01 = 1 inch (25.4 mm) 02 = 2 inch (50.8 mm) 03 = 3 inch (76.2 mm) 04 = 4 inch (101.6 mm) 05 = 5 inch (127.0 mm) 06 = 6 inch (152.4 mm) 07 = 7 inch (177.8 mm) 08 = 8 inch (203.2 mm)</p> <p><b>4. Options</b> NN = no option FN = end-off-stroke limits switches NP = potentiometer FP = end-off-stroke limits switches + potentiometer</p>				<p><b>5. Cross-hole orientation</b> HH = standard cross-hole orientation in both ends MH = cross-hole rotated 90° in both ends</p> <p><b>6. Color of housing</b> N = black</p> <p><b>7. Type of connector</b> C = Packard Electric Pack-Con D = no connector (flying leads)</p> <p><b>8. Front adapter</b> A = cross-hole 0.25 inch B = fork 0.25 inch</p>			

# Electrak<sup>®</sup> 050 – Electrical Connections

## Without Option

Actuator supply voltage	[Vdc]	
DE12		12
DE24		24
DE36		36

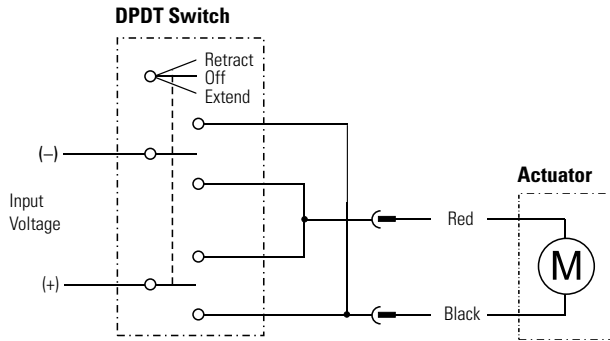

Connect the black lead to positive and red to negative to extend the actuator. Change polarity to retract the actuator.

## Option Potentiometer

Actuator supply voltage	[Vdc]	
DE12		12
DE24		24
DE36		36
Potentiometer type		wire-wound
Potentiometer max. input voltage	[Vdc]	32
Potentiometer max. power	[W]	2
Potentiometer linearity	[%]	± 0.25
Potentiometer output resolution	[ohm/mm]	
DExx-17W41		22.0
DExx-17W42		21.9
DExx-17W44		21.2

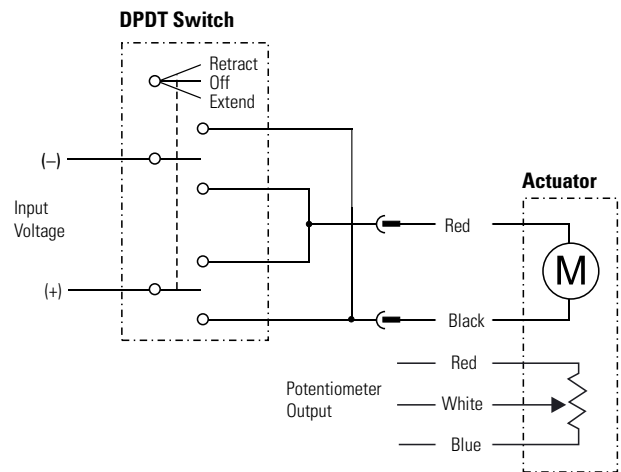

Connect the black lead to positive and red to negative to extend the actuator. Change polarity to retract the actuator. The potentiometer output has 0 ohm between white and red when the actuator is fully retracted.

## Electrak® 1 S – Technical Features



### Standard Features

- Compact and lightweight
- Integrated end of stroke limit switches
- Corrosion resistant housing
- Self-locking acme screw drive system
- Maintenance free
- Ideal for replacement of comparable size pneumatic and hydraulic cylinders

### General Specifications

Screw type	acme
Nut type	acme
Manual override	no
Anti-rotation	no
Static load holding brake	no (self-locking)
Safety features	end of stroke limit switches motor auto reset thermal switch
Electrical connections	flying leads with connector
Compliances	CE

### Compatible Controls

Contact customer support at [www.thomsonlinear.com/cs](http://www.thomsonlinear.com/cs)

# Electrak<sup>®</sup> 1 S – Technical Specifications

Mechanical Specifications		
Max. static load <sup>(1)</sup>	[N (lbf)]	1300 (300)
Max. dynamic load (Fx)	[N (lbf)]	
Sxx -09A04		110 (25)
Sxx -09A08		225 (50)
Sxx -17A08		340 (75)
Sxx -17A16		340 (75)
Speed @ no load/max. load	[mm/s (in/s)]	
Sxx -09A04		78/64 (3.1/2.5)
Sxx -09A08		39/29 1.5/1.1)
Sxx -17A08		21/16 (0.8/0.6)
Sxx -17A16		10/8 (0.4/0.3)
Min. ordering stroke (S) length	[in]	1
Max. ordering stroke (S) length	[in]	8
Ordering stroke length increments	[in]	1
Operating temperature limits	[°C (F)]	-25 – 65 (-13 – 150)
Full load duty cycle @ 25 °C (77 °F)	[%]	25
End play, maximum	[mm (in)]	0.9 (0.04)
Restraining torque	[Nm (lbf-in)]	2.3 (1.7)
Protection class - static		IP66
Salt spray resistance	[h]	96

(1) Max. static load at fully retracted stroke

Electrical Specifications		
Available input voltages <sup>(1)</sup>	[Vdc]	12, 24
Input voltage tolerance	[%]	± 10
Current draw @ no load/max. load	[A]	
S12 -09A04		0.8/3.8
S12 -09A08		0.8/4.4
S12 -17A08		0.8/4.1
S12 -17A16		0.8/3.8
S24 -09A04		0.4/1.6
S24 -09A08		0.4/2.0
S24 -17A08		0.4/1.9
S24 -17A16		0.4/1.6
Motor leads length	[mm (in)]	100 (4)
Motor leads cross section	[mm <sup>2</sup> (AWG)]	1 (18)

# Electrak<sup>®</sup> 1 S – Dimensions

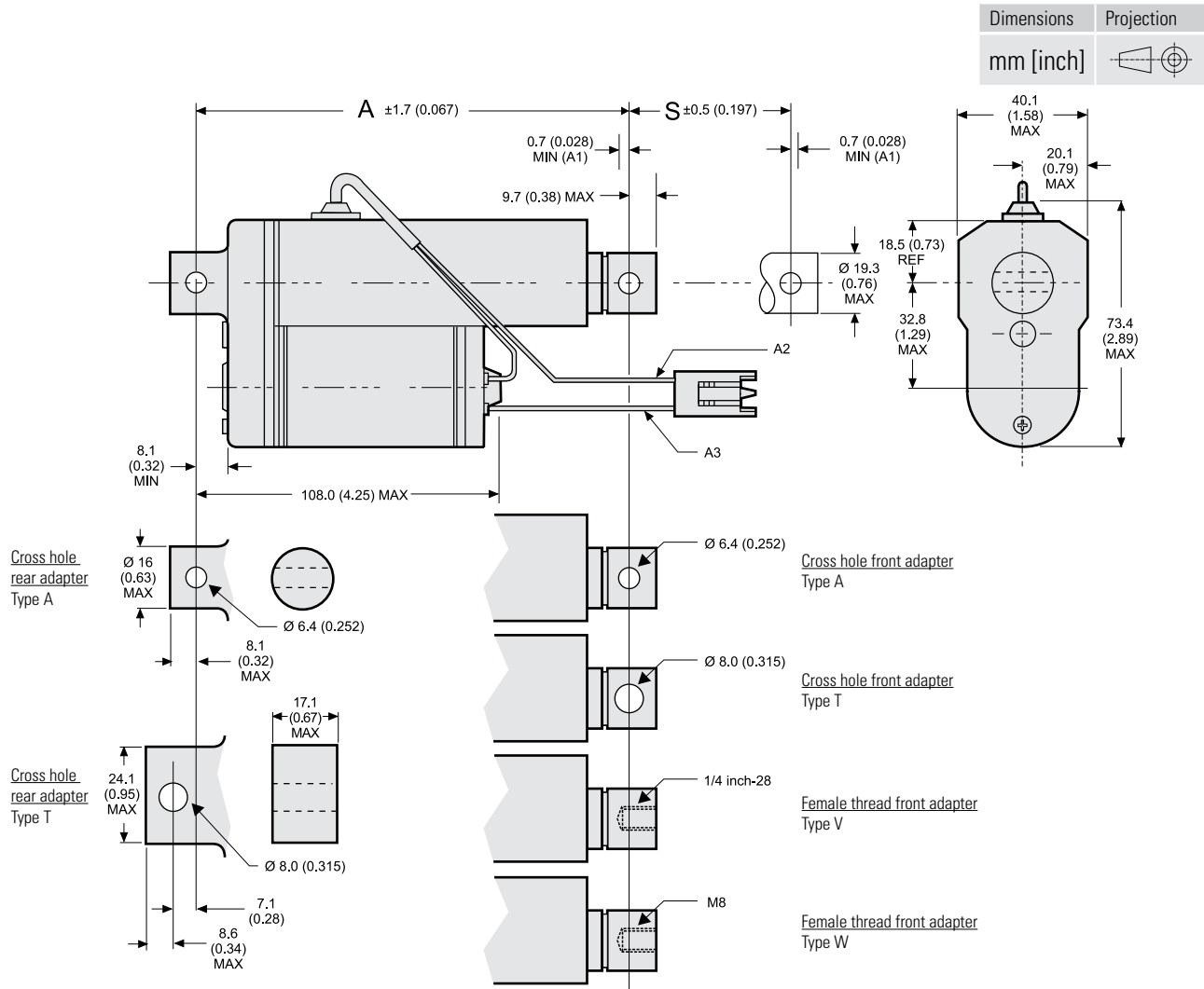

S: stroke  
A: retracted length  
A1: installation must include at least this much coast beyond limit switch shut off  
A2: black lead for 12 Vdc units, white lead for 24 Vdc units  
A3: yellow lead

Stroke, Retracted Length and Weight Relationships								
Ordering stroke (S)	[in]	1	2	3	4	5	6	8
Electrical stroke*	[mm]	21	46	72	97	122	148	199
	[in]	0.82	1.82	2.82	3.82	4.82	5.82	7.82
Retracted length (A)	[mm]	135	160	185	211	236	262	312
	[in]	5.3	6.3	7.3	8.3	9.3	10.3	12.3
Weight	[kg]	0.52	0.54	0.60	0.64	0.66	0.68	0.74
	[lbf]	1.15	1.20	1.35	1.40	1.45	1.50	1.60

\* The electrical stroke occurs when the internal limit switches switch off the power to the motor. The installation then must allow the extension tube to coast at least 0.7 mm (0.028 in) beyond that position before it becomes mechanically blocked to travel any further (distance A1). If there is no mechanical block, the extension tube coasting distance will depend on the load. No load means the longest coasting distance while the distance becomes shorter as the load becomes higher. The exact coasting distance depends on the load, in which direction the load acts (push or pull), the mounting orientation of the actuator, and any added friction to the system by guides or other installations, and has to be determined on a case-by-case basis.



# Electrak<sup>®</sup> 1 S – Performance Diagrams

Speed and Current vs. Load 12 Vdc Models

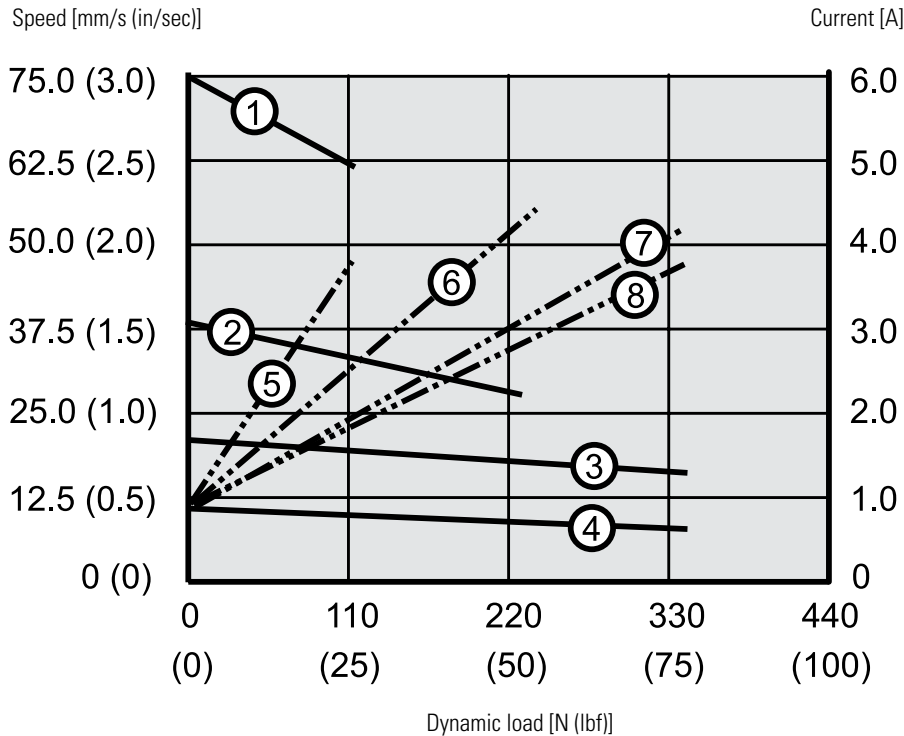

Speed

- 1: S12-09A04 (110 N (25 lbf))
- 2: S12-09A08 (225 N (50 lbf))
- 3: S12-17A08 (340 N (75 lbf))
- 4: S12-17A16 (340 N (75 lbf))

Current

- 5: S12-09A04 (110 N (25 lbf))
- 6: S12-09A08 (225 N (50 lbf))
- 7: S12-17A08 (340 N (75 lbf))
- 8: S12-17A16 (340 N (75 lbf))

Speed and Current vs. Load 24 Vdc Models

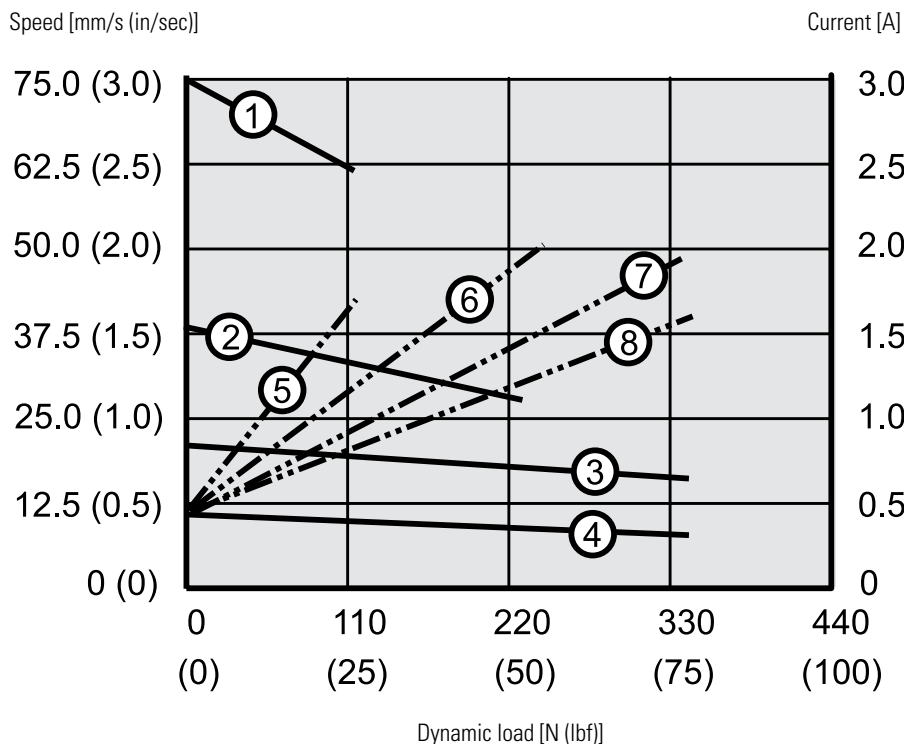

Speed

- 1: S24-09A04 (110 N (25 lbf))
- 2: S24-09A08 (225 N (50 lbf))
- 3: S24-17A08 (340 N (75 lbf))
- 4: S24-17A16 (340 N (75 lbf))

Current

- 5: S24-09A04 (110 N (25 lbf))
- 6: S24-09A08 (225 N (50 lbf))
- 7: S24-17A08 (340 N (75 lbf))
- 8: S24-17A16 (340 N (75 lbf))

# Electrak® 1 S – Ordering Key

Ordering Key						
1	2	3	4	5	6	7
<b>S12</b>	<b>C</b>	<b>09A04</b>	<b>04</b>	<b>C</b>	<b>A</b>	<b>A</b>
<p><b>1. Model and input voltage</b> S12 = Electrak 1, 12 Vdc S24 = Electrak 1, 24 Vdc</p> <p><b>2. CE compliance</b> – = no C = yes</p> <p><b>3. Dynamic load capacity, screw type and maximum speed</b> 09A04 = 110 N (25 lbf), acme, 75 mm/s (3 in/s) 09A08 = 225 N (50 lbf), acme, 45 mm/s (1,8 in/s) 17A08 = 340 N (75 lbf), acme, 26 mm/s (1 in/s) 17A16 = 340 N (75 lbf), acme, 16 mm/s (0,6 in/s)<sup>(1)</sup></p> <p><b>4. Ordering stroke length</b> 01 = 1 inch (25.4 mm) 02 = 2 inch (50.8 mm) 03 = 3 inch (76.2 mm) 04 = 4 inch (101.6 mm) 05 = 5 inch (127.0 mm) 06 = 6 inch (152.4 mm) 08 = 8 inch (203.2 mm)</p>			<p><b>5. Connector option</b> C = Packard Electric Pac-Con</p> <p><b>6. Front adapter option</b> A = Cross hole 0.25 inch T = Cross hole 8 mm V = Female thread 1/4 inch-28 W = Female thread M8</p> <p><b>7. Rear adapter option</b> A = Cross hole 0.25 inch T = Cross hole 8 mm</p> <p>(1) Not possible in combination with 6 or 8 inch stroke.</p>			

# Electrak<sup>®</sup> 1 S – Electrical Connections

## Without Option

Actuator supply voltage	[Vdc]	
S12		12
S24		24

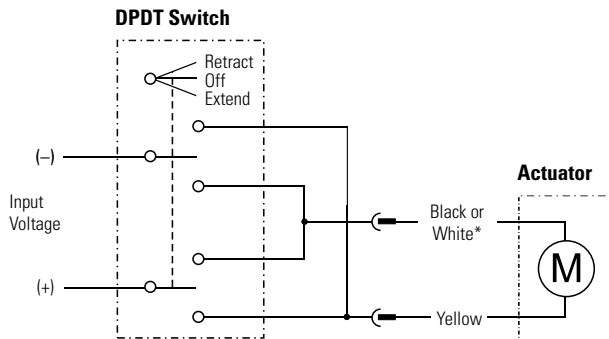

\* Black for 12 Vdc supply voltage  
 White for 24 Vdc supply voltage

Connect the yellow lead to positive and black or white to negative to extend the actuator. Change polarity to retract the actuator. The actuator should be protected from overload conditions by a customer-provided fuse in the circuit (6 A for 12 Vdc and 3 A for 24 Vdc).

# Electrak® 1 SP – Technical Features



## Standard Features

- Compact and lightweight
- Integrated 10 kOhm potentiometer feedback
- Corrosion resistant housing
- Self-locking acme screw drive system
- Maintenance free
- Internally restrained extension tube
- Ideal for replacement of comparable size pneumatic and hydraulic cylinders

## General Specifications

Screw type	acme
Nut type	acme
Manual override	no
Anti-rotation	no
Static load holding brake	no (self-locking)
Safety features	motor auto reset thermal switch
Electrical connections	flying leads with connector to the motor, cable with flying leads to the potentiometer
Compliances	CE

## Compatible Controls

Contact customer support at [www.thomsonlinear.com/cs](http://www.thomsonlinear.com/cs)

# Electrak<sup>®</sup> 1 SP– Technical Specifications

Mechanical Specifications		
Max. static load <sup>(1)</sup>	[N (lbf)]	1300 (300)
Max. dynamic load (Fx)	[N (lbf)]	
SPxx -09A04		110 (25)
SPxx -09A08		225 (50)
SPxx -17A08		340 (75)
SPxx -17A16		340 (75)
Speed @ no load/max. load	[mm/s (in/s)]	
SPxx -09A04		78/64 (3.1/2.5)
SPxx -09A08		39/29 1.5/1.1)
SPxx -17A08		21/16 (0.8/0.6)
SPxx -17A16		10/8 (0.4/0.3)
Min. ordering stroke (S) length	[in]	1
Max. ordering stroke (S) length	[in]	8
Ordering stroke length increments	[in]	1
Operating temperature limits	[°C (F)]	-25 – 65 (-13 – 150)
Full load duty cycle @ 25 °C (77 °F)	[%]	25
End play, maximum	[mm (in)]	0.9 (0.04)
Restraining torque	[Nm (lbf-in)]	2.3 (1.7)
Protection class - static		IP66
Salt spray resistance	[h]	96

(1) Max. static load at fully retracted stroke

Electrical Specifications		
Available input voltages <sup>(1)</sup>	[Vdc]	12, 24
Input voltage tolerance	[%]	± 10
Current draw @ no load/max. load	[A]	
SP12 -09A04		0.8/3.8
SP12 -09A08		0.8/4.4
SP12 -17A08		0.8/4.1
SP12 -17A16		0.8/3.8
SP24 -09A04		0.4/1.6
SP24 -09A08		0.4/2.0
SP24 -17A08		0.4/1.9
SP24 -17A16		0.4/1.6
Motor leads length	[mm (in)]	100 (4)
Motor leads cross section	[mm <sup>2</sup> (AWG)]	1 (18)
Potentiometer cable length	[mm (in)]	635 (25)
Potentiometer cable diameter	[mm (in)]	5 (0.2)
Pot. cable leads cross section	[mm <sup>2</sup> (AWG)]	0.5 (20)

# Electrak<sup>®</sup> 1 SP – Dimensions

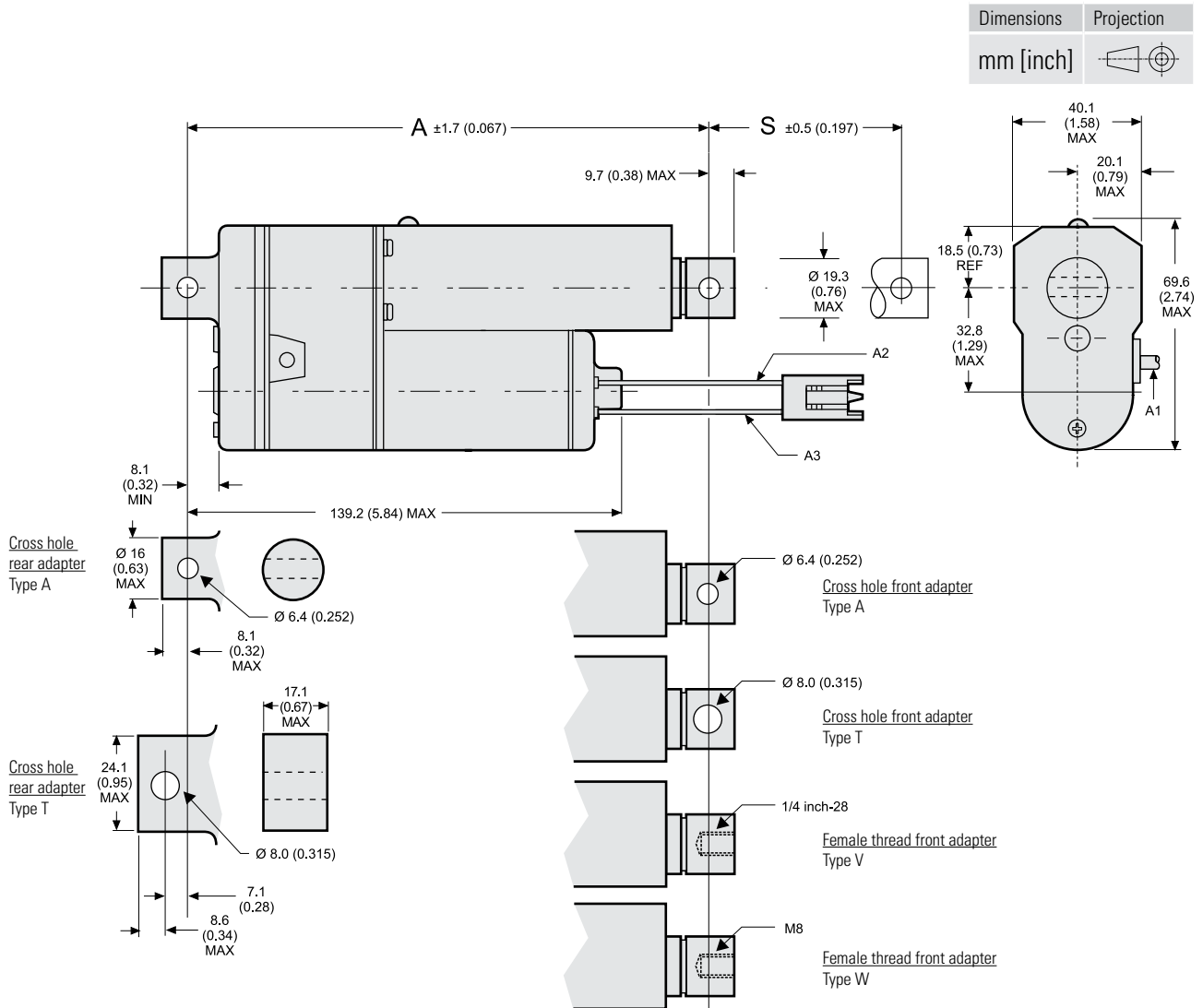

S: stroke  
A: retracted length  
A1: cable for potentiometer feedback, length = 635 mm (25 inch)  
A2: black lead for 12 Vdc units, white lead for 24 Vdc units  
A3: yellow lead

## Stroke, Retracted Length and Weight Relationships

Ordering stroke	[in]	1	2	3	4	5	6*	8
Actual max. stroke (S)	[mm]	29	59	88	117	147	176	235
	[in]	1.2	2.3	3.5	4.6	5.8	6.9	9.2
Retracted length (A)	[mm]	170	198	226	254	282	310	366
	[in]	6.7	7.8	8.9	10.0	11.1	12.2	14.4
Weight	[kg]	0.50	0.55	0.60	0.65	0.70	0.75	0.85
	[lbf]	1.1	1.2	1.3	1.4	1.5	1.6	1.8

\* Six + inch length not possible for SPxx-17A16

# Electrak<sup>®</sup> 1 SP – Performance Diagrams

Speed and Current vs. Load 12 Vdc Models

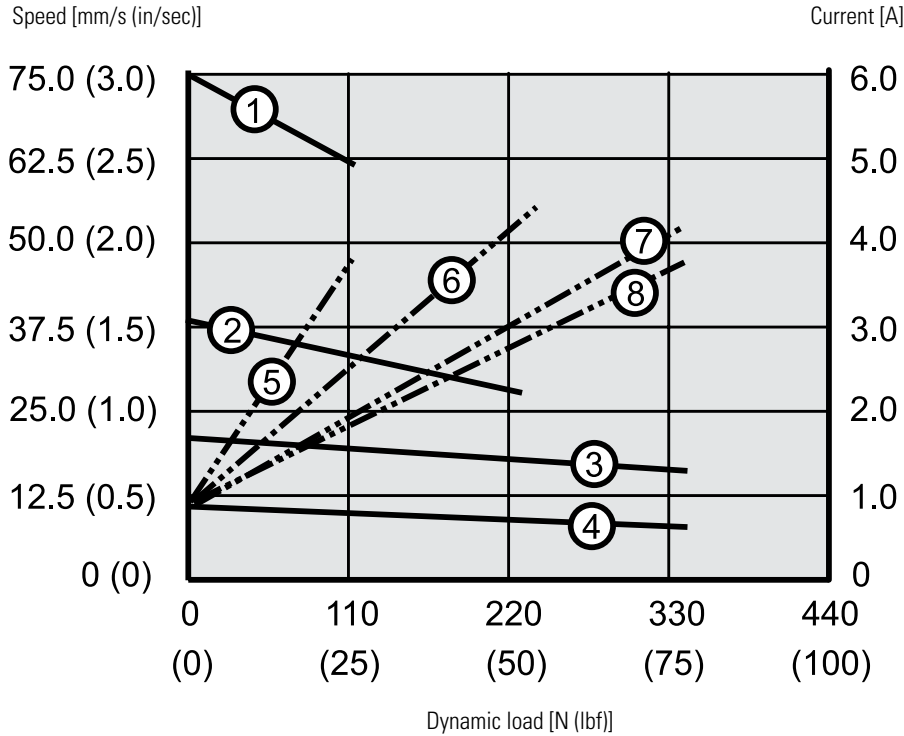

- Speed
- 1: SP12-09A04 (110 N (25 lbf))
  - 2: SP12-09A08 (225 N (50 lbf))
  - 3: SP12-17A08 (340 N (75 lbf))
  - 4: SP12-17A16 (340 N (75 lbf))

- Current
- 5: SP12-09A04 (110 N (25 lbf))
  - 6: SP12-09A08 (225 N (50 lbf))
  - 7: SP12-17A08 (340 N (75 lbf))
  - 8: SP12-17A16 (340 N (75 lbf))

Speed and Current vs. Load 24 Vdc Models

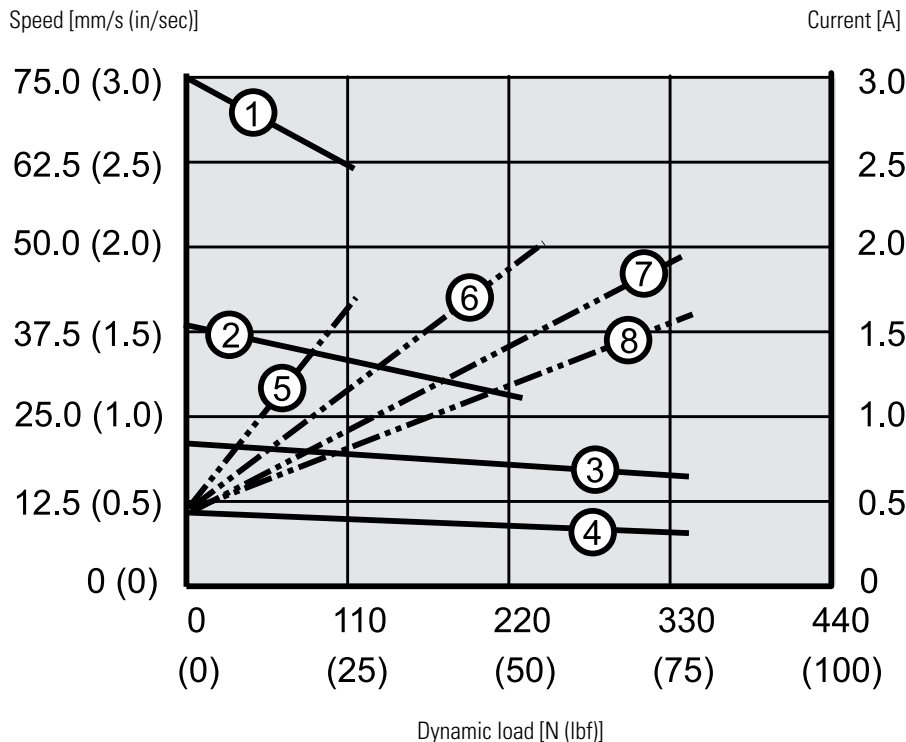

- Speed
- 1: SP24-09A04 (110 N (25 lbf))
  - 2: SP24-09A08 (225 N (50 lbf))
  - 3: SP24-17A08 (340 N (75 lbf))
  - 4: SP24-17A16 (340 N (75 lbf))

- Current
- 5: SP24-09A04 (110 N (25 lbf))
  - 6: SP24-09A08 (225 N (50 lbf))
  - 7: SP24-17A08 (340 N (75 lbf))
  - 8: SP24-17A16 (340 N (75 lbf))

# Electrak® 1 SP – Ordering Key

Ordering Key						
1	2	3	4	5	6	7
<b>SP12</b>	<b>C</b>	<b>09A04</b>	<b>04</b>	<b>C</b>	<b>A</b>	<b>A</b>
<p><b>1. Model and input voltage</b>            SP12 = Electrak 1, potentiometer feedback, 12 Vdc            SP24 = Electrak 1, potentiometer feedback, 24 Vdc</p> <p><b>2. CE compliance</b>            – = no            C = yes</p> <p><b>3. Dynamic load capacity, screw type and maximum speed</b>            09A04 = 110 N (25 lbf), acme, 75 mm/s (3 in/s)            09A08 = 225 N (50 lbf), acme, 45 mm/s (1,8 in/s)            17A08 = 340 N (75 lbf), acme, 26 mm/s (1 in/s)            17A16 = 340 N (75 lbf), acme, 16 mm/s (0,6 in/s) <sup>(1)</sup></p> <p><b>4. Ordering stroke length</b>            01 = 1 inch (25.4 mm)            02 = 2 inch (50.8 mm)            03 = 3 inch (76.2 mm)            04 = 4 inch (101.6 mm)            05 = 5 inch (127.0 mm)            06 = 6 inch (152.4 mm)            08 = 8 inch (203.2 mm)</p>			<p><b>5. Connector option</b>            C = Packard Electric Pac-Con            I = AMP Superseal 2 pin            J = AMP Superseal 5 pin</p> <p><b>6. Front adapter option</b>            A = Cross hole 0.25 inch            T = Cross hole 8 mm            V = Female thread 1/4 inch-28            W = Female thread M8</p> <p><b>7. Rear adapter option</b>            A = Cross hole 0.25 inch            T = Cross hole 8 mm</p> <p>(1) Not possible in combination with 6 or 8 inch stroke.</p>			



# Electrak<sup>®</sup> 1 SP – Electrical Connections

Without Option		
Actuator supply voltage	[Vdc]	
SP12		12
SP24		24
Potentiometer type		wire-wound
Potentiometer resistance	[kOhm]	10
Potentiometer max. input voltage	[Vdc]	32
Potentiometer max. power	[W]	1.5
Resistance tolerance	[%]	5
Potentiometer linearity	[%]	± 0.25
Potentiometer output resolution	[ohm/mm]	
stroke 1 - 2 inch		94.0
stroke 3 - 4 inch		47.0 (63.0) *
stroke 5 - 6 inch		31.5
stroke 8 inch		??

\*All stroke lengths have 47 ohm/mm, except SPxx -17A16 04 (4 inch stroke) has 63 ohm/mm

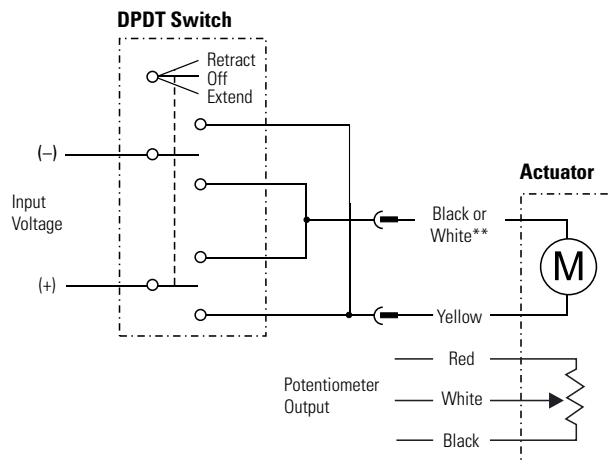

\*\* Black for 12 Vdc supply voltage  
White for 24 Vdc supply voltage

Connect the yellow lead to positive and black or white to negative to extend the actuator. Change polarity to retract the actuator. The potentiometer output has 0 ohm between white and red when the actuator is fully retracted. The actuator should be protected from overload conditions by a customer-provided fuse in the circuit (6 A for 12 Vdc and 3 A for 24 Vdc).

# Electrak® Throttle – Technical Features

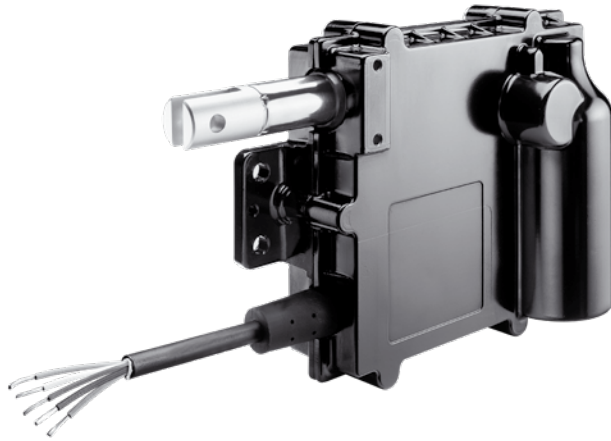

## Standard Features

- Designed for industrial applications
- Rugged aluminium housing with IP69K/IP67 ingress protection
- E-coated housing for corrosion resistance
- Minimal maintenance
- Integrated electronic options
- High end features at a low cost
- Integrated mounting holes

## General Specifications

Screw type	worm
Nut type	worm
Manual override	no
Anti-rotation	yes
Static load holding brake	no (self-locking)
Safety features	end-of-stroke overload protection mid stroke overload protection motor auto reset thermal switch <sup>(1)</sup>
Electrical connections	cable with flying leads or Deutsch connector
Compliances	CE

(1) no thermal switch on units with temperature rating E.

## Optional Mechanical Features

Adapter orientation

Right angle cable exit

Extended operating temperature range

## Optional Electrical Features

Analog position feedback

Internal end-of-stroke limit switches

CAN bus J1939

## Compatible Controls

Contact customer support at [www.thomsonlinear.com/cs](http://www.thomsonlinear.com/cs)

# Electrak<sup>®</sup> Throttle – Technical Specifications

Mechanical Specifications		
Max. static load <sup>(1)</sup> ETxx-084 <sup>(2)</sup> ETxx-174	[N (lbf)]	90 (20) 260 (60)
Max. dynamic load (Fx) ETxx-084 <sup>(2)</sup> ETxx-174	[N (lbf)]	45 (10) 130 (30)
Speed @ no load/max. load ETxx-084 <sup>(2)</sup> ETxx-174	[mm/s (in/s)]	96/83 (3.7/3.3) 48/37(1.9/1.45)
Ordering stroke (S) length	[mm(in)]	50.8 (2)
Retracted length	[mm(in)]	184.7 (7.27)
Operational life	[cycles]	500 000
Operating temperature limits ETxx-xxx-xS ETxx-xxx-xE	[°C (F)]	-40–85 (-40–185) -40–125 (-40–257)
Full load duty cycle @ 25 °C (77 °F)	[%]	50
End play, maximum	[mm (in)]	1.5 (0.06)
Restraining torque	[Nm (lbf-in)]	0
Protection class - static		IP69K, IP65
Weight	[kg (lbf)]	1.11 (2.5)
Salt spray resistance	[h]	500

(1) Max. static load at fully retracted stroke.

(2) The ETxx-084 (high speed version) can only be ordered in combination with operating temperature rating E.

Electrical Specifications		
Available input voltages	[Vdc]	12, 24
Input voltage tolerance	[%]	± 10
Current draw @ no load/max. load <sup>(1)</sup> ET12 (12 Vdc input voltage) ET24 (24 Vdc input voltage)	[A]	1.5/4 0.75/2
Motor cable length	[m (in)]	165 (6.5)
Motor cable diameter	[mm (in)]	11.5 (0.45)
Motor cable leads cross section	[mm <sup>2</sup> (AWG)]	1 (18)

(1) Max. current draw ratings do not include motor inrush current. Typical inrush current values are 12 A at 12 VDC and 6 A at 24 VDC.

# Electrak® Throttle – Dimensions

Dimensions	Projection
mm [inch]	

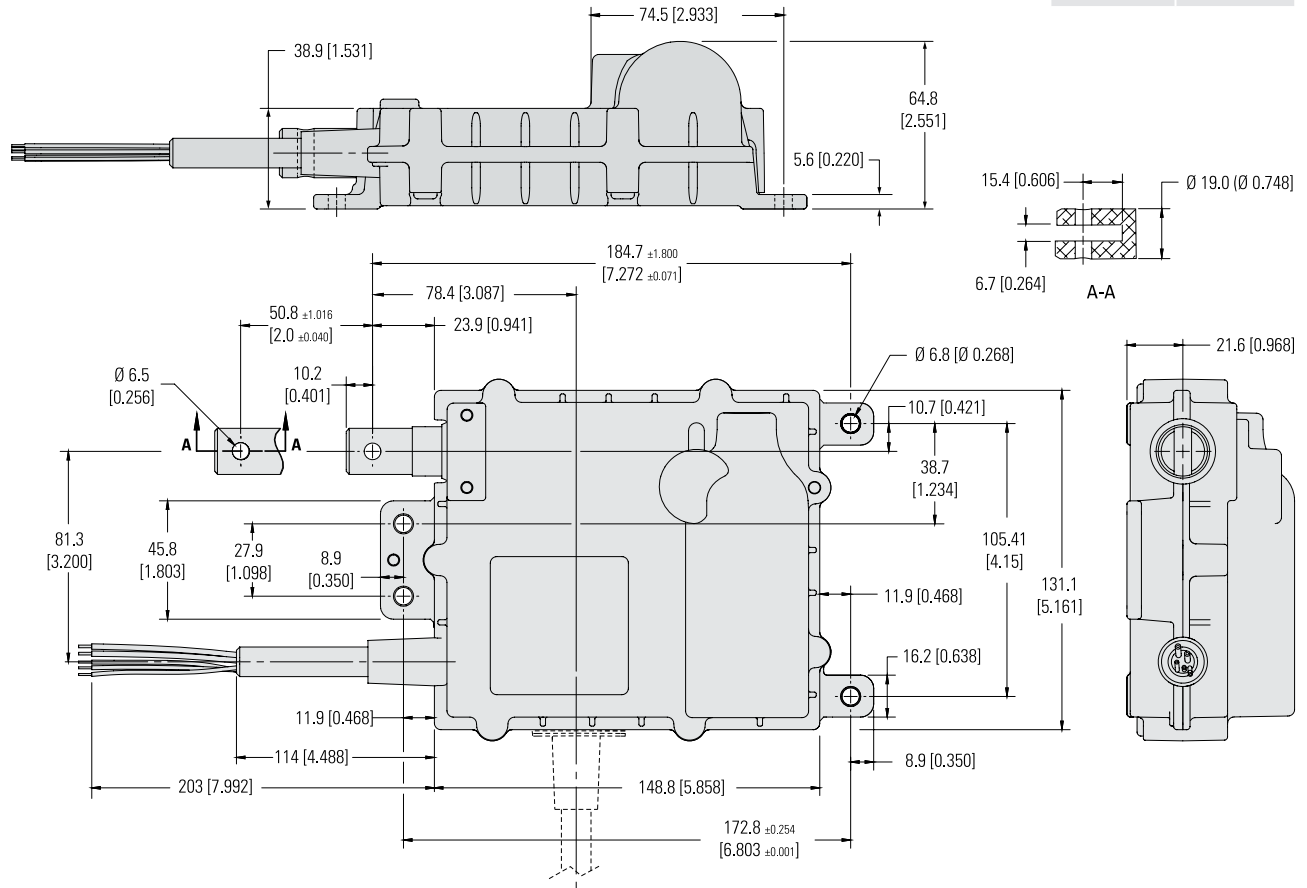

# Electrak<sup>®</sup> Throttle – Performance Diagrams

Speed and Current vs. Load

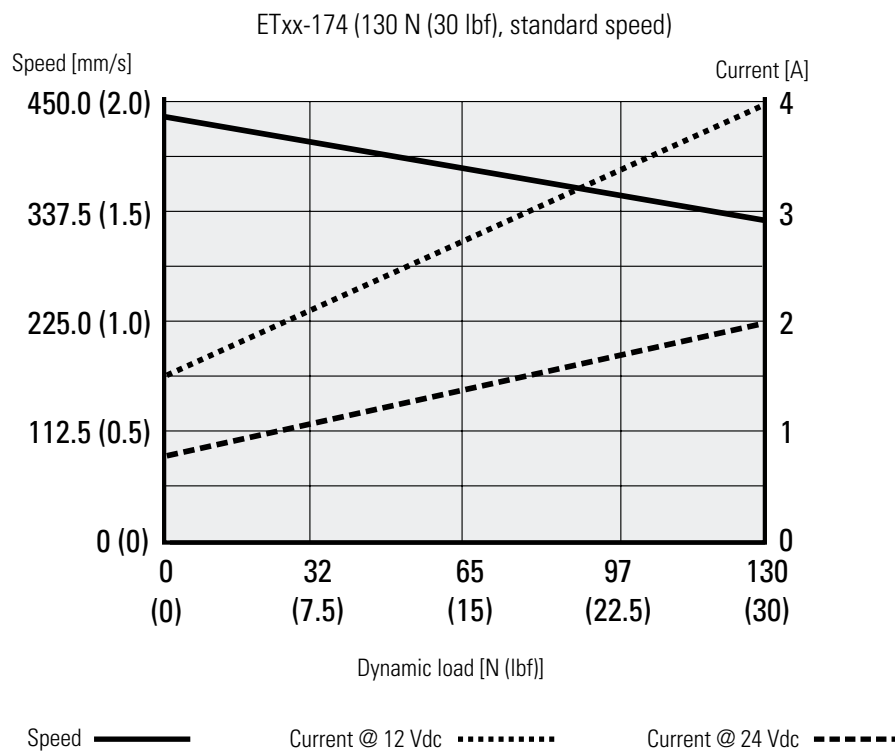
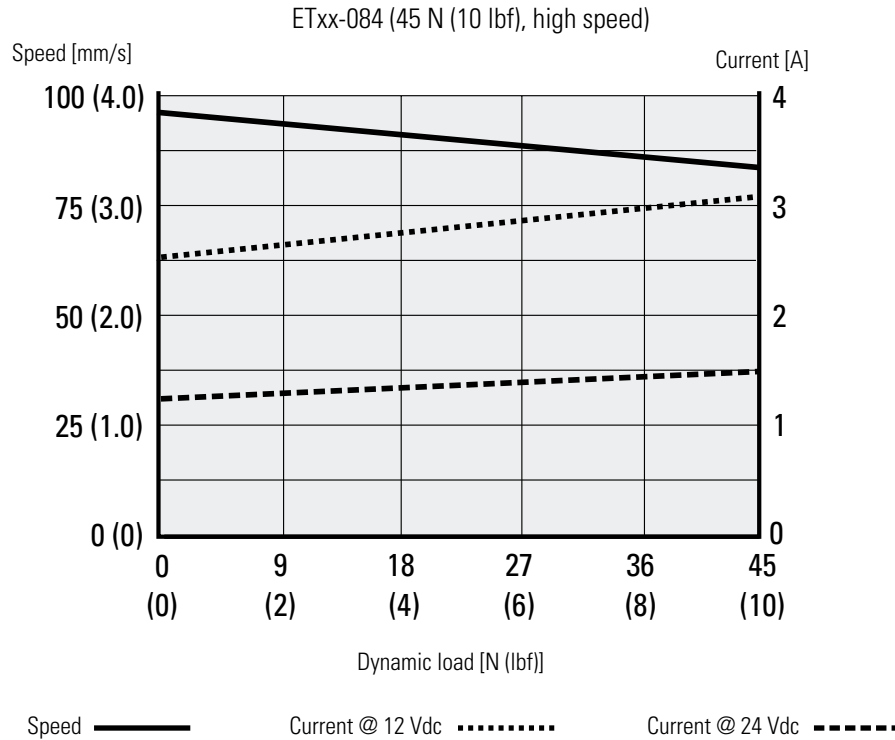

# Electrak® Throttle – Ordering Key

## Ordering Key

1	2	3	4	5	6	7
<b>ET12-</b>	<b>174-</b>	<b>S</b>	<b>S</b>	<b>NP</b>	<b>1</b>	<b>S</b>

### 1. Model and input voltage

ET12 - = Electrak® Throttle, 12 Vdc  
ET24 - = Electrak® Throttle, 24 Vdc

### 2. Max. dynamic load and speed version

084 - = 45 N (10 lbf), high speed <sup>(1)</sup>  
174 - = 130 N (30 lbf), standard speed

### 3. Harness orientation

S = parallel to adapter  
R = rotated 90° in housing

S

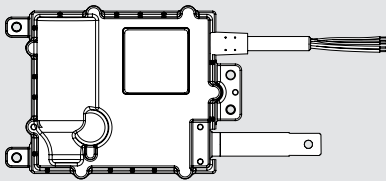

R

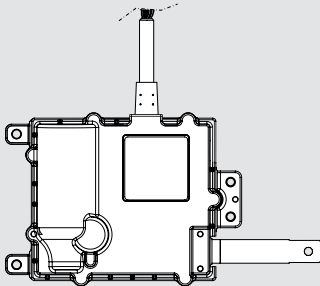

(1) Can only be ordered with high temperature rating (code E in position 4). Note that there is no thermal switch to protect the motor on the high temperature rated models.

### 4. Temperature rating

S = standard: -40 (-40) to +85 (+185) °C (F)  
E = high temperature: -40 (-40) to +125 (+257) °C (F)

### 5. Control option

NP = analog position feedback sensor  
FN = end-of-stroke limit switches  
FP = analog position feedback and end-of-stroke limit switches  
CN = CANBUS SAE J1939

### 6. Connector option

1 = flying leads  
2 = Deutsch DTM04-6P connector

### 7. Adapter option

S = standard adapter orientation  
M = adapter rotated 90°

S

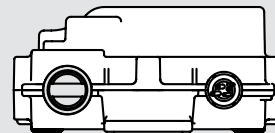

M

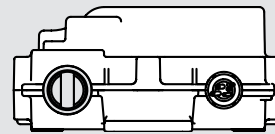

# Electrak<sup>®</sup> Throttle – Electrical Connections

## Option End-of-Stroke Limit Switches

Actuator supply voltage	[Vdc]	
ET12		12
ET24		24

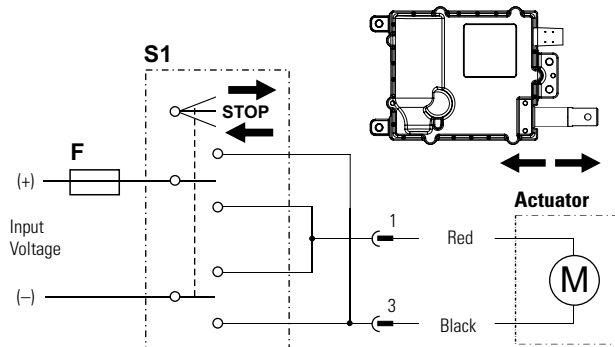

- M Actuator motor
- S1 Double pole double throw (DPDT) switch
- F Fuse

Connect black lead (connector pin 3) to positive and red lead (pin 1) to negative to extend the actuator. Change polarity to retract the actuator. When reaching the ends of stroke, the internal limit switches automatically will stop motion. A clutch is included as a safety feature to stop the motion in case of mid stroke overload.

## Option Analog Feedback

Actuator supply voltage	[Vdc]	
ET12		12
ET24		24
Analog feedback type		non-contact
Analog feedback input voltage, max.	[Vdc in]	32
Analog feedback output voltage	[Vdc out]	< 5 % of VDC in > 75 % of VDC in
Analog feedback output current, max.	[mA]	1
Analog feedback output linearity	[%]	± 1

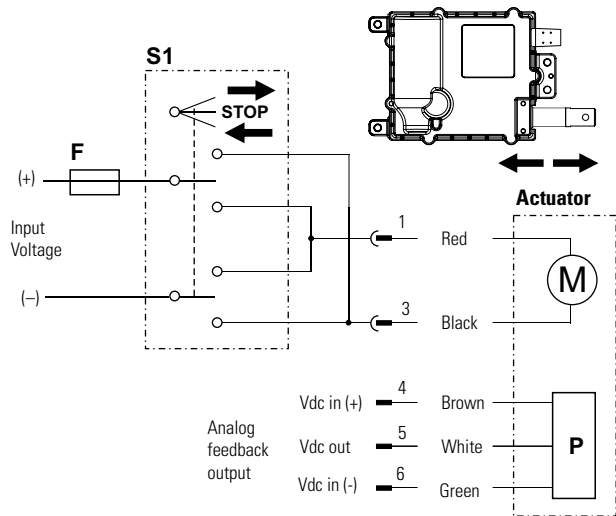

- M Actuator motor
- S1 Double pole double throw (DPDT) switch
- F Fuse
- P Analog feedback device

Connect black lead (connector pin 3) to positive and red lead (pin 1) to negative to extend the actuator. Change polarity to retract the actuator. If the actuator should reach the mechanical end of stroke, the built in clutch will stop the motion. The clutch, however, is a safety feature and should not be used as end of stroke control during normal operation.

The analog feedback device is supplied between brown lead (connector pin 4) and green lead (pin 6), while the output signal is on white lead (pin 5).

# Electrak® Throttle – Electrical Connections

## Option Analog Feedback + End-of-Stroke Limit Switches

Actuator supply voltage	[Vdc]	
ET12		9 - 16
ET24		18 - 32
Analog feedback type		non contact
Analog feedback input voltage, max.	[Vdc in]	32
Analog feedback output voltage	[Vdc out]	
fully retracted		< 5 % of VDC in
fully extended		> 75 % of VDC in
Analog feedback output current, max.	[mA]	1
Analog feedback output linearity	[%]	± 1

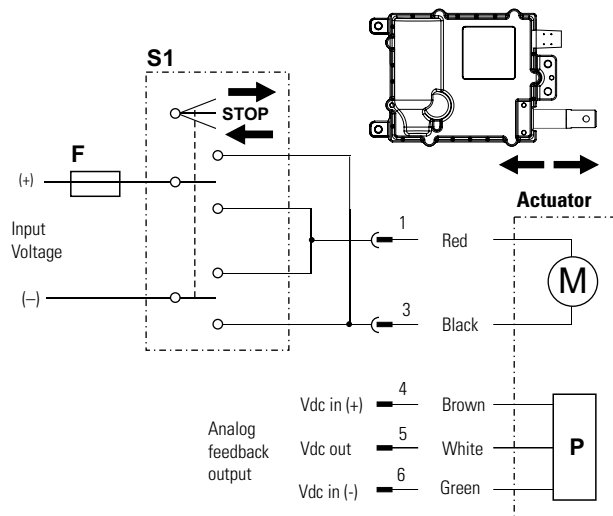

- M Actuator motor
- S1 Double pole double throw (DPDT) switch
- F Fuse
- P Analog feedback device

Connect black lead (connector pin 3) to positive and red lead (pin 1) to negative to extend the actuator. Change polarity to retract the actuator. When reaching the ends of stroke, the internal limit switches automatically will stop motion. A clutch is included as a safety feature to stop the motion in case of mid stroke overload.

The analog feedback device is supplied between brown lead (connector pin 4) and green lead (pin 6), while the output signal is on white lead (pin 5).

## Option CAN bus SAE J1939

Actuator supply voltage	[Vdc]	
ET12		12
ET24		24
CAN bus signal information		see user manual

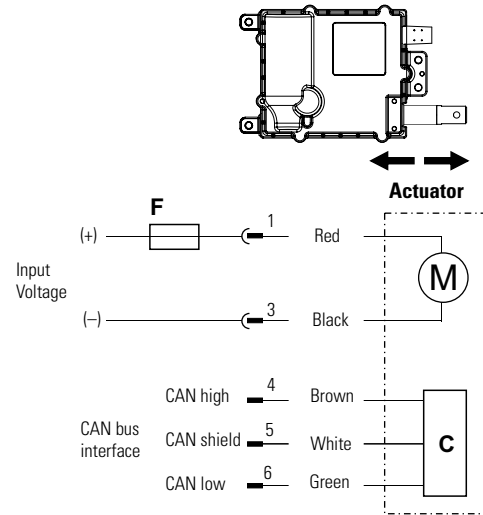

- M Actuator motor
- S1 Double pole double throw (DPDT) switch
- F Fuse
- C CAN bus device

Connect red lead to (connector pin 1) to positive and black (pin 3) to negative to power up the actuator. A clutch is included as a safety feature to stop the motion in case of mechanical overload.

The actuator is controlled via the CAN bus interface on brown lead (connector pin 4), white lead (pin 5) and green lead (pin 6).





# WhisperTrak™ – Technical Features



## Standard Features

- Exceptionally quiet, sound level less than 45 dBa
- Rugged actuator offering IP67 protection
- Compact and light-weight
- Maintenance free
- Average life is 10000 full strokes back and forth at maximum load
- Large number of onboard control option combinations

## General Specifications

Screw type	acme screw
Nut type	lead nut
Manual override	no
Anti-rotation	yes
Static load holding	yes, self-locking
Safety features	-
Electrical connections	cable with flying leads or molex connector
Compliances	CE
Certificates <sup>(1)</sup>	AAMI STD ES60601-1 IEC STD 60601-1 CSA STD C22.2 # 60601-1 (5)

1) 4 kN units greater than 30 cm of stroke are not ETL recognized. ETL certification available on N, E, P and D feedback options only.

## Optional Mechanical Features

- Front and rear adapters orientation
- Black or white housing color

## Optional Electrical Features

- Electronic limit switches
- Low level switching
- Analog position feedback
- Digital position feedback

## Compatible Controls

Contact customer support at [www.thomsonlinear.com/cs](http://www.thomsonlinear.com/cs)

# WhisperTrak™ – Technical Specifications

Mechanical Specifications		
Max. static load Wxx02 Wxx04	[N (lbf)]	2000 (450) 4000 (900)
Max. dynamic load (Fx) Wxx02 Wxx04	[N (lbf)]	2000 (450) 4000 (900)
Speed @ no load/max. load Wxx02-58A Wxx02-54A Wxx04-58A	[mm/s (in/s)]	5.8/4.0 (0.16/0.23) 11.0/8.0 (0.43/0.31) 5.8/4.0 (0.23/0.16)
Min. ordering stroke (S) length	[mm]	100
Max. ordering stroke (S) length <sup>(2)</sup>	[mm]	500
Ordering stroke length increments	[mm]	100
Operating temperature limits	[°C (F)]	-25 – 40 (-13 – 104)
Full load duty cycle @ 25 °C (77 °F) <sup>(1)</sup>	[%]	10
Max. on-time Wxx02-58A Wxx02-54A Wxx04-58A	[s]	180 90 90
End play, maximum	[mm (in)]	0.5 (0.02)
Restraining torque	[Nm (lbf-in)]	0
Protection class - static		IP67
Sound level	[dBa]	< 45
Life, average	[cycles]	10 000

<sup>1)</sup> Thrust is reduced at lower temperatures for 2000 N (450 lbf) high speed (54A) and 4000 N (900 lbf) units with ELS + low level switching (option E).

Electrical Specifications		
Available input voltages <sup>(1)</sup>	[Vdc]	12, 24
Input voltage tolerance	[%]	± 10
Current draw @ no load/max. load W1202-58A W1202-54A W2402-58A W2402-54A W1204-58A W2404-58A	[A]	1.3/4.5 2.5/9.0 0.9/2.2 2.0/4.5 3.0/9.0 1.8/4.5
Current draw @ stall or in-rush W1202-58A W1202-54A W2402-58A W2402-54A W1204-58A W2404-58A	[A]	14.0 21.0 8.0 11.0 21.0 11.0
Cable lengths, standard	[mm (in)]	1000 (39), 2000 (79)
Cable diameter	[mm (in)]	6.4 (0.25)
Cable motor leads cross section	[mm <sup>2</sup> (AWG)]	1 (18)
Cable signal leads cross section	[mm <sup>2</sup> (AWG)]	0.34 (22)

# WhisperTrak™ – Dimensions

Dimensions	Projection
mm [inch]	

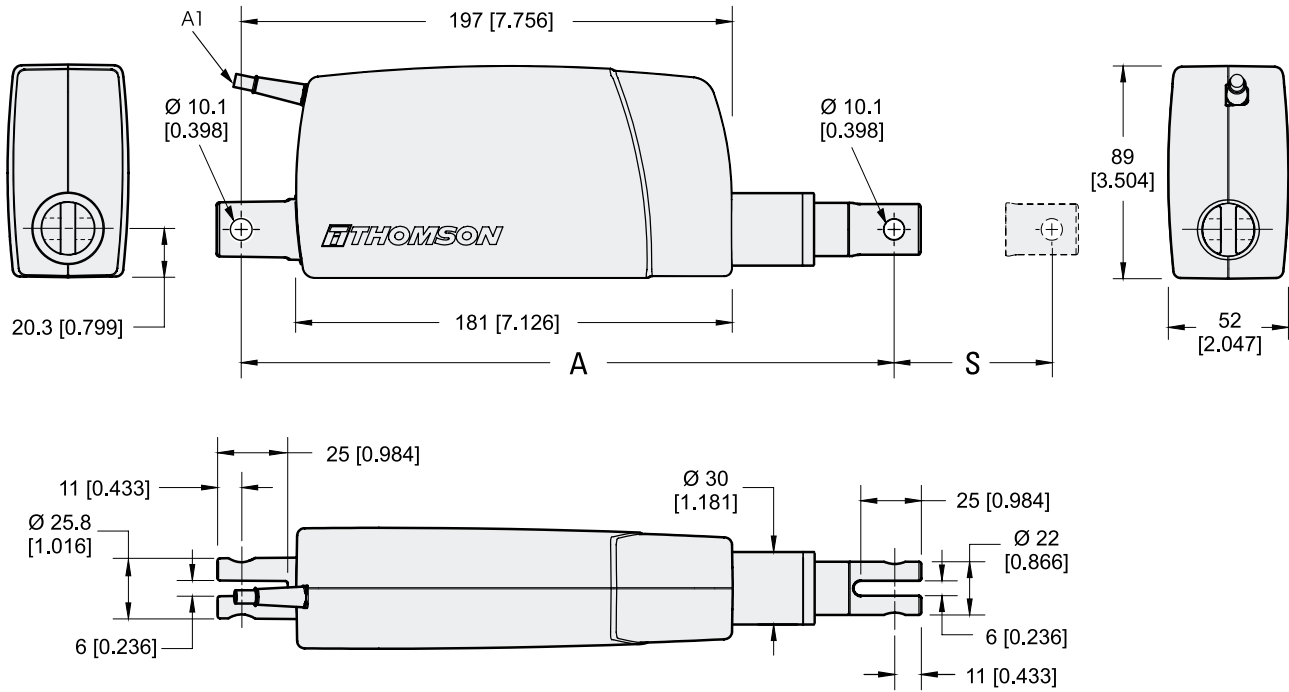

A1: Cable

## Stroke, Retracted Length and Weight Relationships

Actuator Type		Wxx02 (max. load 2000 N (450 lbf))					Wxx04 (max. load 4000 N (900 lbf))				
		100	200	300	400	500	100	200	300	400	500
Ordering stroke (S)	[mm]	100	200	300	400	500	100	200	300	400	500
Retracted length (A)	[mm]	238	338	438	589	689	246	346	446	597	697
	[in]	9.37	13.31	17.24	23.19	27.13	9.69	13.62	17.56	23.50	27.44
Weight	[kg]	1.20	1.35	1.50	1.65	1.80	1.36	1.52	1.67	1.82	1.97
	[lbf]	2.65	2.98	3.31	3.64	3.97	3.00	3.35	3.68	4.01	4.34

# WhisperTrak™ – Performance Diagrams

Speed and Current vs. Load

Wxx02-58A (2000 N (450 lbf) Standard Speed)

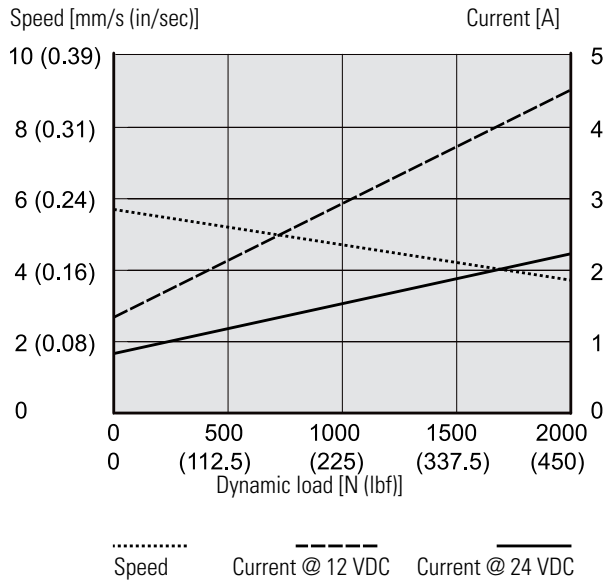

Speed and Current vs. Load

Wxx02-54A (2000 N (450 lbf) High Speed)

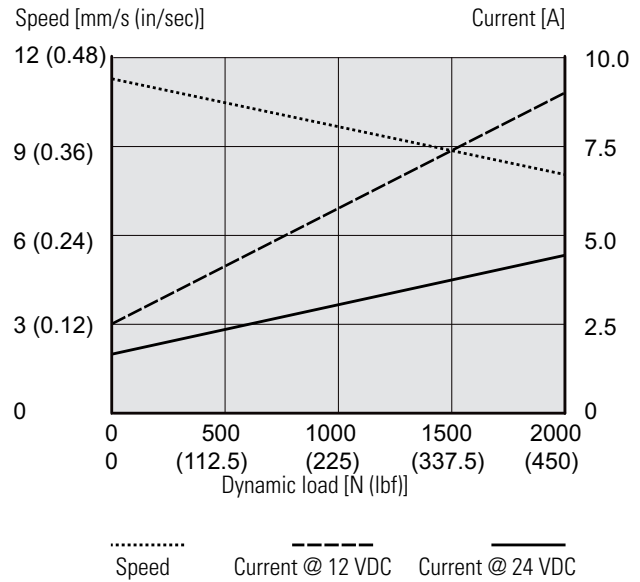

Speed and Current vs. Load

Wxx04-58A (4000 N (900 lbf))

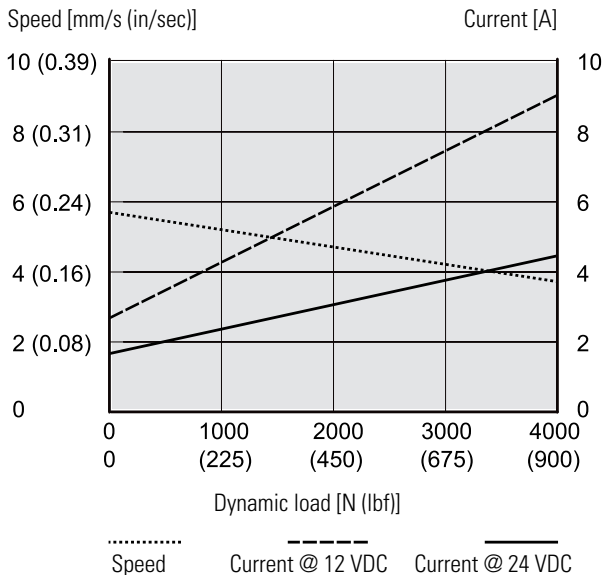

Load Capacity vs. Operating Temperature\*

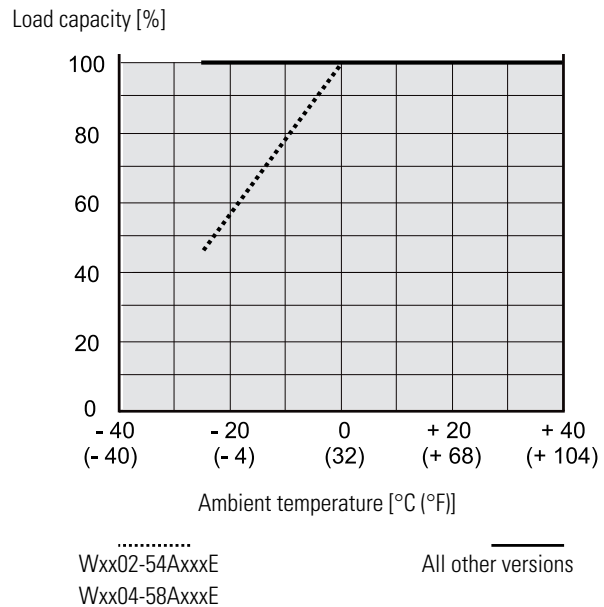

\* Most versions have the same load capacity within the permissible operating temperature limits. Two versions (Wxx02-54AxxxE and Wxx04-58AxxxE) have a reduced capacity at lower temperatures. Also see "Option Electronic Limit Switches + Low Level Switching" on page 120.

# WhisperTrak™ – Ordering Key

## Ordering Key

1	2	3	4	5	6	7	8
<b>W12</b>	<b>02-</b>	<b>58A</b>	<b>10</b>	<b>N</b>	<b>A</b>	<b>1</b>	<b>B</b>

### 1. Model and input voltage

W12 = WhisperTrak, 12 Vdc  
W24 = WhisperTrak, 24 Vdc

### 2. Max. dynamic load capacity

02 - = 2000 N (450 lbf)  
04 - = 4000 N (900 lbf)

### 3. Rated no load speed

58A = 5.8 mm/s (0.228 in/s) - standard speed version  
54A = 11.0 mm/s (0.433 in/s) - high speed version<sup>(1)</sup>

### 4. Ordering stroke length

10 = 100 mm (3.937 in)  
20 = 200 mm (7.874 in)  
30 = 300 mm (11.811 in)  
40 = 400 mm (15.748 in)  
50 = 500 mm (19.685 in)

### 5. Onboard control system options <sup>(2)</sup>

N = standard (no control - for use with Thomson DCG Control)  
X = electronic limit switches (ELS)  
E = ELS + low level switching  
P = analog position feedback  
D = digital feedback  
Y = ELS + digital feedback  
Z = ELS + analog position feedback

(1) Only available for the 2000 N (450 lbf) version  
(2) See possible combinations in the table below

### 6. Anti-rotation mechanism and adapter positions

A = anti-rotation, adapter holes in standard position  
M = anti-rotation, adapter holes turned 90°

Definition of rear adapter hole positions

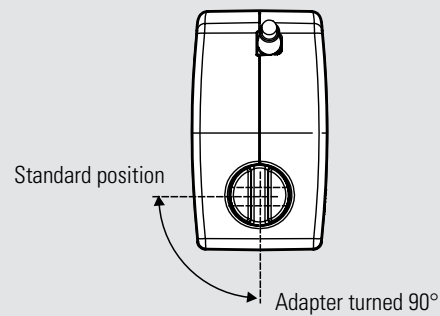

### 7. Cable and connector options

1 = 1 meter (39 in) long cable with flying leads  
3 = 2 meter (79 in) long cable with Molex type connector, only possible with control options N and D (connector compatible with DCG control)

### 8. Housing color

B = black  
W = white

## Possible Combinations of onboard Control Options and WhisperTrak Models

		Actuator Input Voltage, Max. Dynamic Load and Speed Version					
		12 Vdc			24 Vdc		
		2000 N		4000 N	2000 N		4000 N
Control Option Name	Option Code	Standard	High	Standard	Standard	High	Standard
Standard (for use with DCG control)	N				•	•	•
Electronic Limit Switches (ELS)	X	•			•	•	•
ELS + Low-Level Switching	E	•	•	•	•	•	•
Analog Position Feedback	P	•	•	•	•	•	•
Digital Feedback	D	•	•	•	•	•	•
ELS + Digital Feedback	Y	•			•	•	•
ELS + Analog Position Feedback	Z	•			•	•	•

# WhisperTrak™ – Electrical Connections

## Without Option (standard)

Actuator supply voltage	[Vdc]	
W12	12	
W24	24	

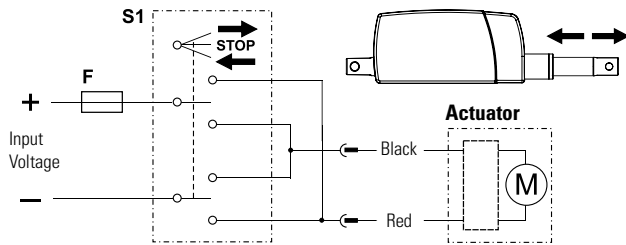

- M Actuator motor
- S1 Double pole double throw (DPDT) switch
- F Fuse

This option is to be selected when using the DCG control. Without the DCG control, this option is only compatible with the 24 Vdc, 2kN standard speed (W2402-58A) actuator.

Connect the red lead to positive and black to negative to extend the actuator. Change polarity to retract the actuator.

The actuator must be switched off when reaching the ends of stroke or at a mid-stroke overload condition to avoid causing damage to the actuator.

## Option Electronic Limit Switches

Actuator supply voltage	[Vdc]	
W12	12	
W24	24	

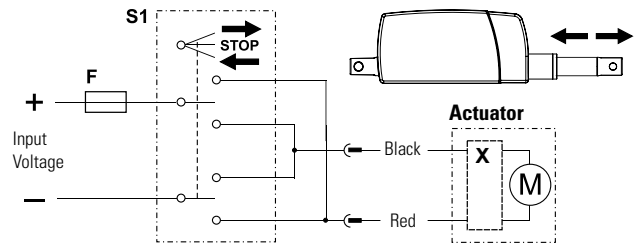

- M Actuator motor
- S1 Double pole double throw (DPDT) switch
- F Fuse
- X Electronic limit switches device

Connect the red lead to positive and black to negative to extend the actuator. Change polarity to retract the actuator.

The actuator will automatically switch off when reaching the ends of stroke or at a mid-stroke overload condition.

# WhisperTrak™ – Electrical Connections

## Option Electronic Limit Switches - Low Level Switching

Actuator supply voltage [Vdc]	
W12	12
W24	24
Low-level switch input voltage [Vdc]	9 - 16

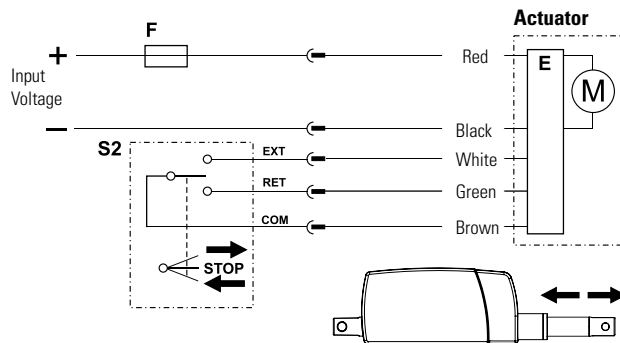

- M Actuator motor
- S2 Single pole double throw (SPDT) switch
- F Fuse
- E Electronic limits switches and low-level switching device

To power the actuator, connect positive to red lead and negative to black. The direction of the extension tube is controlled by using the low-level switching inputs. Connect the COM (common) on (brown lead) to the EXT (extend) input (white lead) or RET (retract) input (green lead).

The actuator will automatically switch off when reaching the ends of stroke or a at mid-stroke overload condition. The standard factory switch off setting is rated dynamic load plus 20% nominal, which means 2400 N nominal for the 2000 N model and 4800 N nominal for the 4000 N model.

Two actuator versions with this option will also have a reduced load capacity at lower temperatures. They are Wxx02-54AxxxE (2000 N high speed version) and Wxx04-58AxxxE (4000 N version). See diagram "Load Capacity vs. Operating Temperature" on page 117.

## Option Analog Position Feedback

Actuator supply voltage [Vdc]	
W12	12
W24	24
Analog feedback type	non-contact
Analog feedback input voltage [Vdc]	5
Analog feedback input voltage tolerance [Vdc]	± 0.5
Analog feedback output voltage [Vdc]	
fully retracted	0.5
fully extended	4.5
Analog feedback output accuracy [mm]	± 0.12
Analog feedback output resolution [V/mm]	
stroke 100 mm	0.0400
stroke 200 mm	0.0200
stroke 300 mm	0.0133
stroke 400 mm	0.0010
stroke 500 mm	0.0008

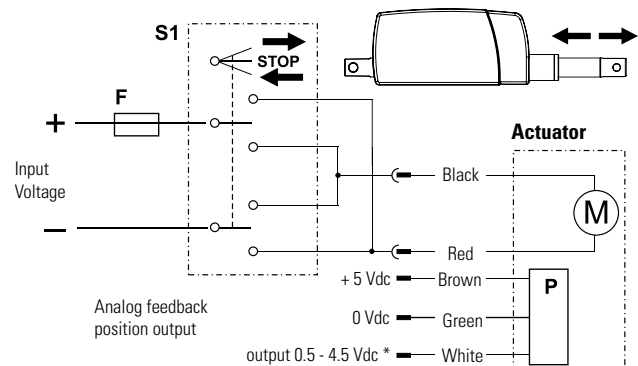

\* From 0.5 V at fully retracted (←) to 4.5 V at fully extended (→).

- M Actuator motor
- S1 Double pole double throw (DPDT) switch
- F Fuse
- P Analog position feedback device

Connect the red lead to positive and black to negative to extend the actuator. Change polarity to retract the actuator.

The actuator must be switched off when reaching the ends of stroke or at a mid-stroke overload condition to avoid causing damage to the actuator.

The analog feedback device is supplied between brown lead and green lead, while the output signal is on white lead.



# WhisperTrak™ – Electrical Connections

Option Digital Position Feedback		
Actuator supply voltage	[Vdc]	12 24
Digital feedback type		incremental encoder
Number of channels		2
Digital feedback input voltage	[Vdc]	3.8 - 24
Digital feedback output type		open collector
Digital feedback output current, max.	[mA]	100
Digital feedback output resolution	[pulse/mm]	0.1003 0.2006
Wxxx-58A		
Wxxx-54A		

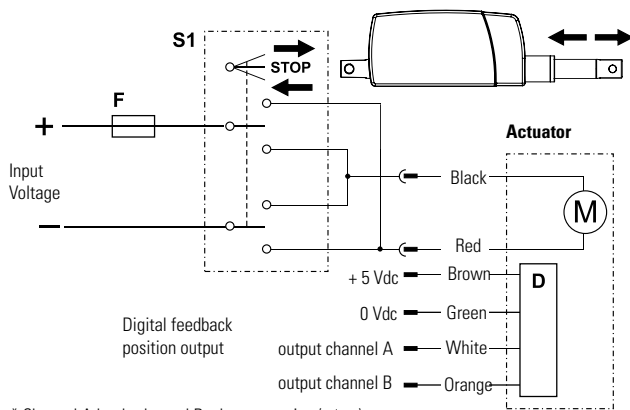

\* Channel A leads channel B when retracting (←).

- M Actuator motor
- S1 Double pole double throw (DPDT) switch
- F Fuse
- D Digital position feedback device

Connect the red lead to positive and black to negative to extend the actuator. Change polarity to retract the actuator.

The actuator must be switched off when reaching the ends of stroke or at a mid-stroke overload condition to avoid causing damage to the actuator.

The digital feedback device is supplied between brown lead and green lead, while output signal channel A is on white lead and channel B on orange lead.

Option Analog Position Feedback + Electronic Limit Switches		
Actuator supply voltage	[Vdc]	12 24
Analog feedback type		non-contact
Analog feedback input voltage	[Vdc]	5
Analog feedback input voltage tolerance	[Vdc]	± 0.5
Analog feedback output voltage	[Vdc]	0.5 4.5
Analog feedback output accuracy	[mm]	± 0.12
Analog feedback output resolution	[V/mm]	0.0400 0.0200 0.0133 0.0010 0.0008
stroke 100 mm		
stroke 200 mm		
stroke 300 mm		
stroke 400 mm		
stroke 500 mm		

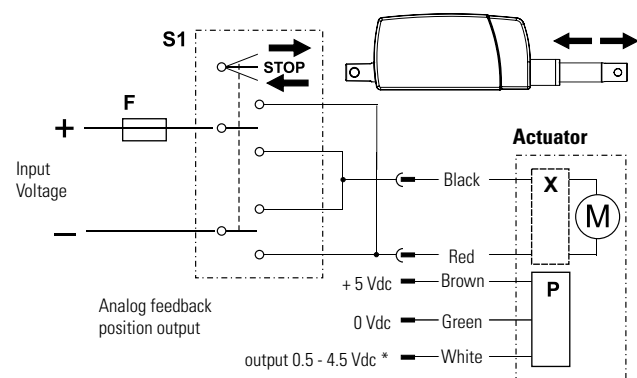

\* From 0.5 V at fully retracted (←) to 4.5 V at fully extended (→).

- M Actuator motor
- S1 Double pole double throw (DPDT) switch
- F Fuse
- X Electronic limit switch device
- P Analog position feedback device

Connect the red lead to positive and black to negative to extend the actuator. Change polarity to retract the actuator

The actuator will automatically switch off when reaching the ends of stroke or at a mid-stroke overload condition.

The analog feedback device is supplied between brown lead and green lead, while the output signal is on white lead.

# WhisperTrak™ – Electrical Connections

## Option Digital Position Feedback + Electronic Limit Switches

Actuator supply voltage	[Vdc]	
W12		12
W24		24
Digital feedback type		incremental encoder
Number of channels		2
Digital feedback input voltage	[Vdc]	3.8 - 24
Digital feedback output type		open collector
Digital feedback output current, max.	[mA]	100
Digital feedback output resolution	[pulse/mm]	
Wxxx-58A		0.1003
Wxxx-54A		0.2006

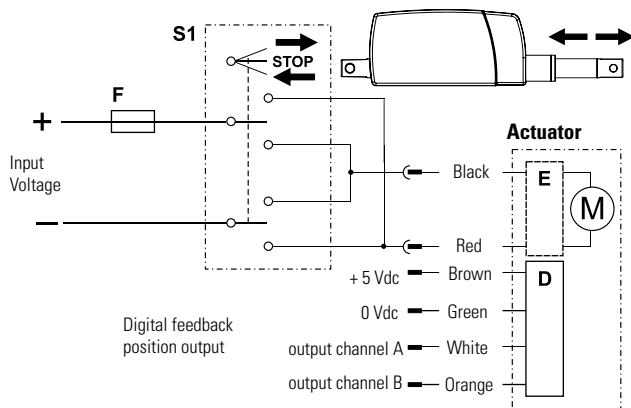

\* Channel A leads channel B when retracting (←).

- M Actuator motor
- S1 Double pole double throw (DPDT) switch
- F Fuse
- X Electronic limit switch device
- D Digital position feedback device

Connect the red lead to positive and black to negative to extend the actuator. Change polarity to retract the actuator.

The actuator will automatically switch off when reaching the ends of stroke or at a mid-stroke overload condition.

The digital feedback device is supplied between brown lead and green lead, while output signal channel A is on white lead and channel B on orange lead.



## DMHD – Technical Features



### Standard Features

- Self-supporting column in extruded anodized aluminium with high load torque capability
- Onboard electronics with many optional functions
- 12 or 24 Vdc as standard input voltages
- Static load up to 18 kN (4050 lbf)
- Dynamic load up to 16 kN (3584 lbf)
- Stroke up to 600 mm
- Speed up to 71 mm/s (2.8 in/s)
- Protection class static IP67, IP69K and dynamic IP66
- Rugged, robust and strong
- T-slot grooves along the entire profile
- Maintenance free

### General Specifications

Screw type	ball
Nut type	load lock ball nut
Manual override	no
Anti-rotation	yes
Static load holding brake	yes
Safety features	Electrak monitoring package: current monitoring voltage monitoring temperature monitoring load trip point calibration internal end-of-stroke limit switches <sup>(1)</sup> end-of-stroke dynamic braking
Electrical connections	cable with flying leads
Compliances	CE

(1) Dynamic braking is included at the ends of stroke for all DMHD actuators. Dynamic braking offered throughout the entire stroke length only on low-level switching and J1939 options.

### Optional Electronic Control Features

J1939 CAN bus
Synchronization option
Low-level switching
End-of-stroke indication output
Analog position output
Digital position output

### Control Option Combinations

Same as for Electrak HD - see table on page 20

### Accessories

T-slot bolts

### Compatible Controls

Contact customer support at [www.thomsonlinear.com/cs](http://www.thomsonlinear.com/cs)

# DMHD – Technical Specifications

Mechanical Specifications		
Max. static load <sup>(1)</sup>	[kN (lbf)]	18 (4050)
Max. dynamic load (Fx)	[kN (lbf)]	
DMHDxxB017		1.7 (382)
DMHDxxB026		2.6 (585)
DMHDxxB045		4.5 (1012)
DMHDxxB068		6.8 (1529)
DMHDxxB100		10 (2248)
DMHDxxB160		16 (3584)
Max. load torque, dyn. and static	[Nm (lbf-in)]	710 (6284)
Speed @ no load/max. load <sup>(2)</sup>	[mm/s (in/s)]	
DMHDxxB017		71/58 (2.8/2.28)
DMHDxxB026		40/32 (1.6/1.3)
DMHDxxB045		24/19 (0.94/0.75)
DMHDxxB068		18/14 (0.71/0.55)
DMHDxxB100		11/9 (0.43/0.35)
DMHDxxB160		7/5 (0.27/0.21)
Min. ordering stroke (S) length	[mm]	100
Max. ordering stroke (S) length <sup>(3)</sup>	[mm]	600
Ordering stroke length increments	[mm]	50
Operating temperature limits	[°C (F)]	-40 – 85 (-40 – 185)
Full load duty cycle @ 25 °C (77 °F)	[%]	25 <sup>(4)</sup>
End play, maximum	[mm (in)]	1.2 (0.047)
Protection class - static		IP67, IP69K
Protection class - dynamic		IP65

<sup>1</sup> Max. static load at fully retracted stroke.

<sup>2</sup> For units with the synchronization option, the speed is 25% lower at any load.

<sup>3</sup> 500 mm max. for 16 kN

<sup>4</sup> For DMHDxx-B100 and DMHDxx-160, unidirectional load, the duty cycle is 15%.

Electrical Specifications		
Available input voltages	[Vdc]	12, 24
Input voltage tolerance	[Vdc]	
DMHD12 (12 Vdc input voltage)		9 - 16
DMHD24 (24 Vdc input voltage)		18 - 32
Current draw @ no load/max. load	[A]	
DMHD12B017		3/18
DMHD24B017		1.5/9
DMHD12B026		3/18
DMHD24B026		1.5/9
DMHD12B045		3/18
DMHD24B045		1.5/9
DMHD12B068		3/20
DMHD24B068		1.5/10
DMHD12B100		3/18
DMHD24B100		1.5/9
DMHD12B160		3/20
DMHD24B160		1.5/10
Motor leads cross section	[mm <sup>2</sup> (AWG)]	2 (14)
Signal leads cross section	[mm <sup>2</sup> (AWG)]	0.5 (20)
Standard cable lengths	[m (in)]	1.5, 5 (59, 197)
Cable diameter	[mm (in)]	7.5 (.295)
Flying lead length	[mm (in)]	76 (3)
Stripped lead length	[mm (in)]	6 (0.25)

# DMHD – Dimensions

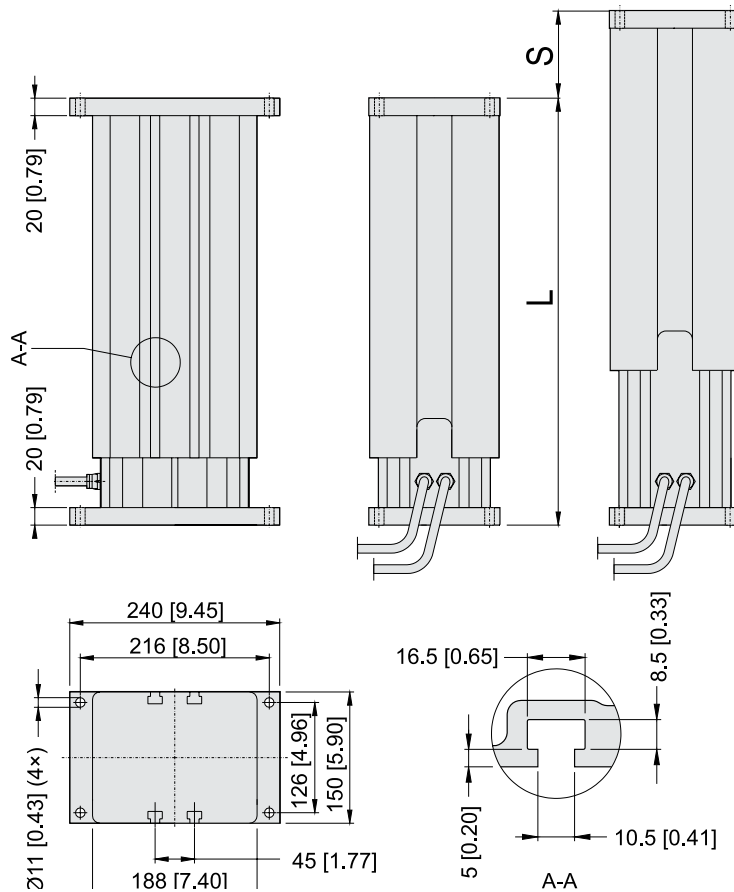

Dimensions	Projection
mm [inch]	

Note. All models have two cables except models with control option EXX which has one placed in the center of the profile.

## Stroke, Retracted Length and Weight Relationships

Ordering stroke (S)	[mm]	100	150	200	250	300	350	400	450	500	550	600
Retracted length (A) for DMHDxxB017(026,045,068)	[mm]	357	407	457	507	557	657	707	757	807	857	907
	[in]	14.1	16.0	18.0	20.0	21.9	23.9	27.8	29.8	31.8	33.7	35.7
Weight for DMHDxxB017(026,045,068)	[kg]	21.8	23.3	24.9	26.4	28.0	30.8	32.3	33.8	35.5	37.0	38.5
	[lbf]	48.0	51.3	54.8	58.1	61.6	67.8	71.1	74.4	78.1	81.4	84.7
Retracted length (A) for DMHDxxB100	[mm]	407	457	507	557	607	657	707	757	807	857	907
	[in]	16.0	18.0	20.0	21.9	23.9	23.9	27.8	29.8	31.8	33.7	35.7
Weight for DMHDxxB100	[kg]	22.0	23.6	25.1	26.7	28.2	31.1	32.5	34.7	36.4	38.0	39.5
	[lbf]	48.4	51.9	55.2	58.7	62.0	68.4	71.5	76.3	80.1	83.6	86.9
Retracted length (A) for DMHDxxB160 *	[mm]	407	457	507	557	607	657	707	757	807	-	-
	[in]	16.0	18.0	20.0	21.9	23.9	23.9	27.8	29.8	31.8	-	-
Weight for DMHDxxB160 *	[kg]	22.3	23.9	25.4	27.0	28.5	31.4	32.5	34.7	36.4	-	-
	[lbf]	49.1	52.6	55.9	59.4	62.7	69.1	71.5	76.3	80.1	-	-

\* Max. stroke for DMHDxxB160 (16 kN (3584 lbf)) is 500 mm.

# DMHD – Performance Diagrams

Load vs. Speed <sup>(1)</sup>

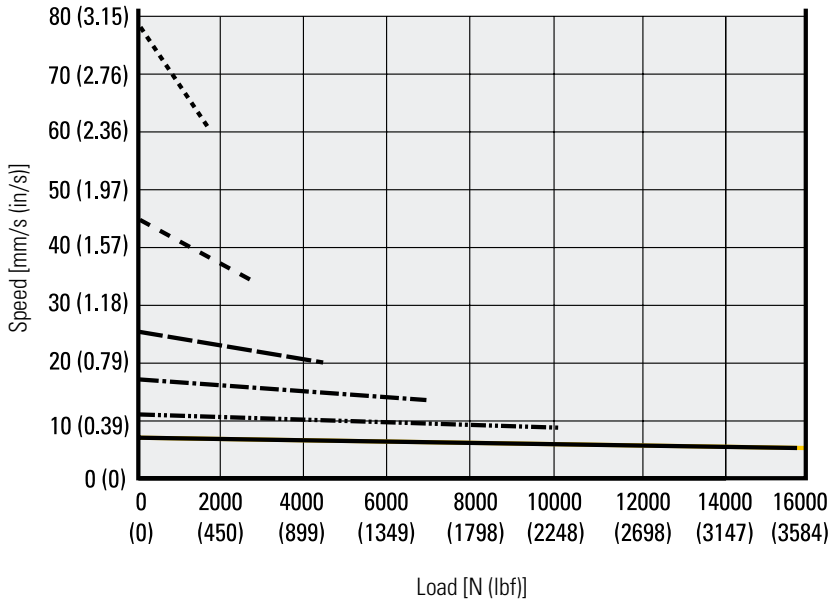

Off Center Load Capacity

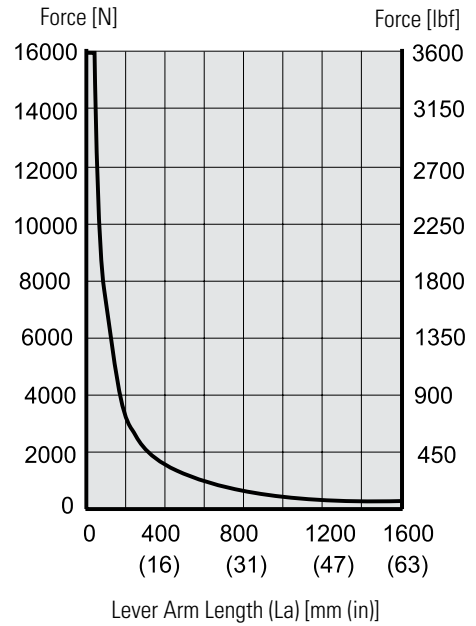

<sup>1</sup> Curves valid for all units except those with the synchronization option, where the speed at any load is 25% lower than for those without.

Load vs. Current

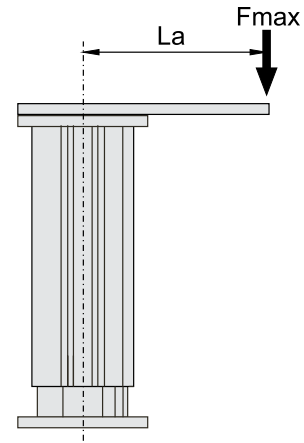
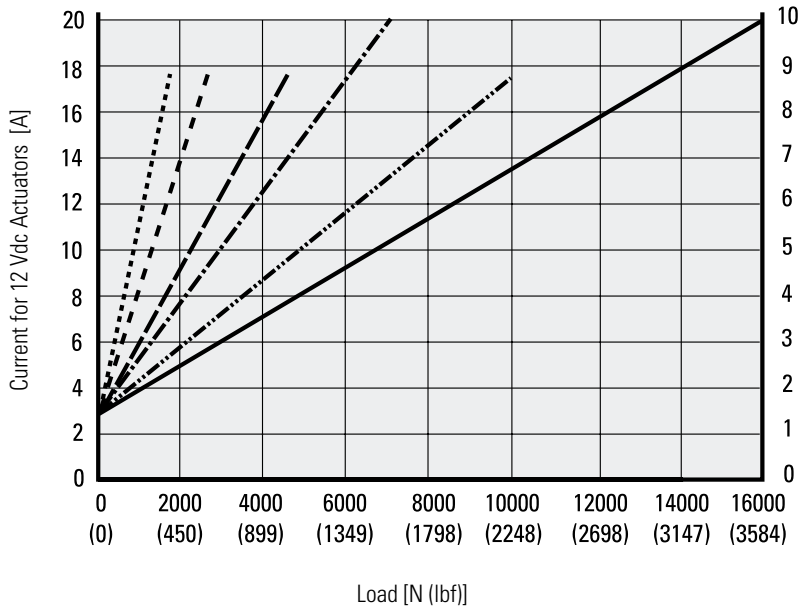

- |                               |       |                                |         |                               |       |
|-------------------------------|-------|--------------------------------|---------|-------------------------------|-------|
| DMHDxxB017 (1.7 kN (382 lbf)) | ..... | DMHDxxB045 (4.5 kN (1012 lbf)) | -----   | DMHDxxB100 (10 kN (2248 lbf)) | ..... |
| DMHDxxB026 (2.6 kN (585 lbf)) | ----- | DMHDxxB068 (6.8 kN (1529 lbf)) | -.-.-.- | DMHDxxB160 (16 kN (3584 lbf)) | ————— |

**Note!** Curves were generated at an ambient temperature of 21°C (70°F). Different ambient temperature and individual actuator characteristics can produce slightly different values.

# DMHD – Ordering Key

Ordering Key				
1	2	3	4	5
DMHD12	B026-	0300	LXX	5
<p><b>1. Model and input voltage</b> DMHD12 = lifting column type DMHD, 12 Vdc DMHD24 = lifting column type DMHD, 24 Vdc</p> <p><b>2. Screw type, dynamic load capacity</b> B017- = ball screw, 1.7 kN (382 lbf) B026- = ball screw, 2.6 kN (585 lbf) B045- = ball screw, 4.5 kN (1012 lbf) B068- = ball screw, 6.8 kN (1529 lbf) B100- = ball screw, 10 kN (2248 lbf) B160- = ball screw, 16 kN (3584 lbf)</p> <p><b>3. Ordering stroke length <sup>(1) (2)</sup></b> 0100 = 100 mm 0150 = 150 mm 0200 = 200 mm 0250 = 250 mm 0300 = 300 mm 0350 = 350 mm 0400 = 400 mm 0450 = 450 mm 0500 = 500 mm 0550 = 550 mm 0600 = 600 mm</p>		<p><b>4. Electrak Modular Control System options</b> EXX = Electronic Monitoring Package only ELX = EXX + end-of-stroke indication output EXP = EXX + analog (potentiometer) position output EXD = EXX + digital position output ELP = ELX + analog (potentiometer) position output ELD = ELX + digital position output LXX = EXX + low-level signal motor switching LLX = EXX + LXX + end-of-stroke indication output LXP = EXX + LXX + analog (potentiometer) position output CNO = J1939 CAN bus + open-loop speed control SYN = LXX + Synchronization option</p> <p><b>5. Cable length and connection type</b> 1 = 1.5 m long cable with flying leads 2 = 5.0 m long cable with flying leads</p> <p>(1) Other stroke lengths available upon request. Contact customer support (2) Max. stroke for DMHDxxB160 (16 kN (3584 lbf)) is 500 mm.</p>		



# DMHD – Electrical Connections

## Option Type EXX

Actuator supply voltage	[Vdc]	
DMHD12		12
DMHD24		24

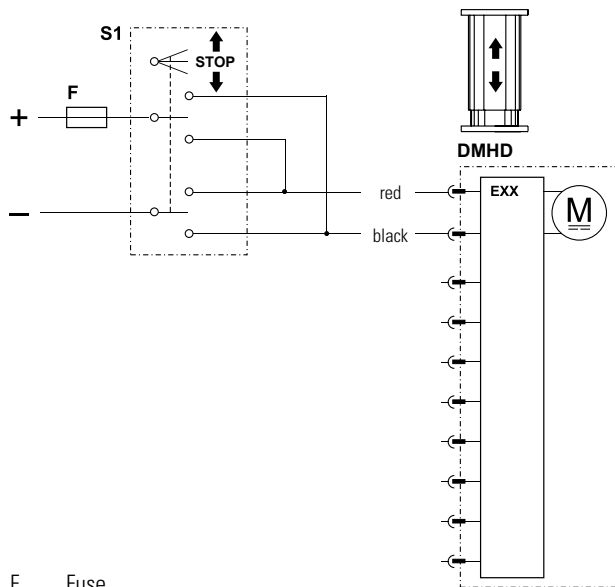

F Fuse  
S1 Double pole double throw switch

Control option EXX contains Electrak Monitoring Package features, guaranteeing safe operation of the actuator and equipment. With control option EXX, the polarity of the motor voltage is switched by a customer-supplied switch (switch, relay, etc.) to make the actuator extend or retract. The switch, power supply, wiring and all other components must be able to handle the motor current for the actuator model and load being used, as well as the inrush current (up to three times the max. continuous current for the max. load being used for up to 150 milliseconds).

## Option Type ELX

Actuator supply voltage	[Vdc]	
DMHD12		12
DMHD24		24
Output contact type		potential free
Limit switch max. switch voltage	[Vdc]	140
Limit switch max. switch current	[mA]	350
Limit switch max. switch power	[W]	5

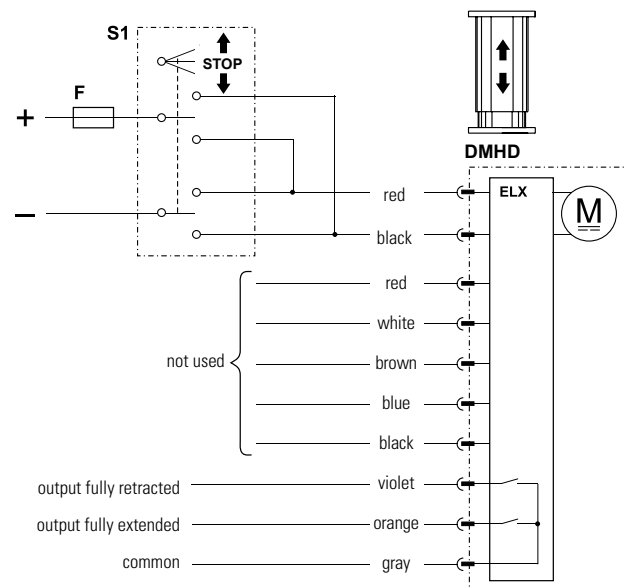

F Fuse  
S1 Double pole double throw switch

Control option ELX works as option EXX but also has two outputs that indicate when the extension tube is in its fully extended or retracted position.

# DMHD – Electrical Connections

Option Type EXP		
Actuator supply voltage	[Vdc]	9 - 16 18 - 32
Potentiometer type		wire-wound
Potentiometer max. input voltage	[Vdc]	32
Potentiometer max. power	[W]	1
Potentiometer linearity	[%]	± 0.25
Potentiometer output resolution	[ohm/mm]	65.6 32.8 19.7 9.8
50 - 100 mm stroke 150 - 250 mm stroke 300 - 500 mm stroke 550 - 600 mm stroke		

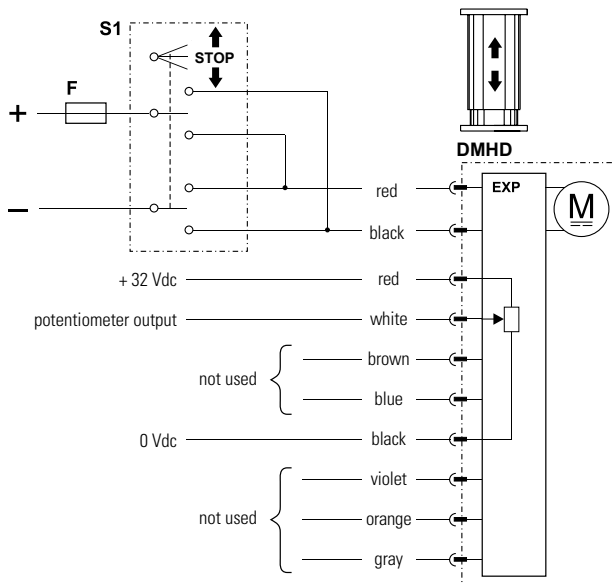

F Fuse  
S1 Double pole double throw switch

Control option EXP works as option EXX but also has an analog (potentiometer) output that will provide feedback on the extension tube position.

Option Type EXD		
Actuator supply voltage	[Vdc]	9 - 16 18 - 32
Encoder type		hall effect
Encoder input voltage	[Vdc]	4 - 24
Encoder output voltage levels	[Vdc]	low (logical zero), typical / max.
		0.1 / 0.25
Encoder resolution	[mm/pulse]	0.28 0.15 0.09 0.07 0.04 0.03
DMHDxx-B017 DMHDxx-B026 DMHDxx-B045 DMHDxx-B068 DMHDxx-B100 DMHDxx-B160		

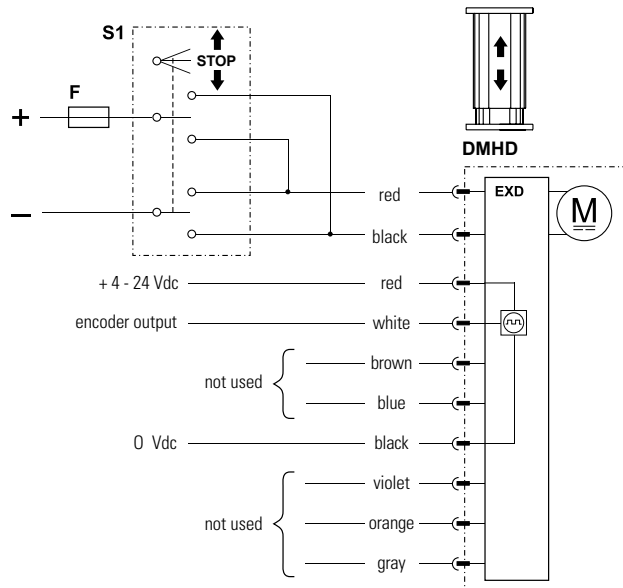

F Fuse  
S1 Double pole double throw switch

Control option EXD works as option EXX but also has a single-channel encoder output that will provide feedback on the extension tube position.

# DMHD – Electrical Connections

Option Type ELP		
Actuator supply voltage	[Vdc]	9 - 16 18 - 32
Output contact type		potential free
Max. output voltage	[Vdc]	140
Max. output current	[mA]	350
Max. output power	[W]	5
Potentiometer type		wire-wound
Potentiometer max. input voltage	[Vdc]	32
Potentiometer max. power	[W]	1
Potentiometer linearity	[%]	± 0.25
Potentiometer output resolution	[ohm/mm]	
50 - 100 mm stroke		65.6
150 - 250 mm stroke		32.8
300 - 500 mm stroke		19.7
550 - 600 mm stroke		9.8

Option Type ELD		
Actuator supply voltage	[Vdc]	9 - 16 18 - 32
Output contact type		potential free
Max. output voltage	[Vdc]	140
Max. output current	[mA]	350
Max. output power	[W]	5
Encoder type		hall effect
Encoder input voltage	[Vdc]	4 - 24
Encoder output voltage levels	[Vdc]	
low (logical zero), typical / max.		0.1 / 0.25
Encoder resolution	[mm/pulse]	
DMHDxx-B017		0.28
DMHDxx-B026		0.15
DMHDxx-B045		0.09
DMHDxx-B068		0.07
DMHDxx-B100		0.04
DMHDxx-B160		0.03

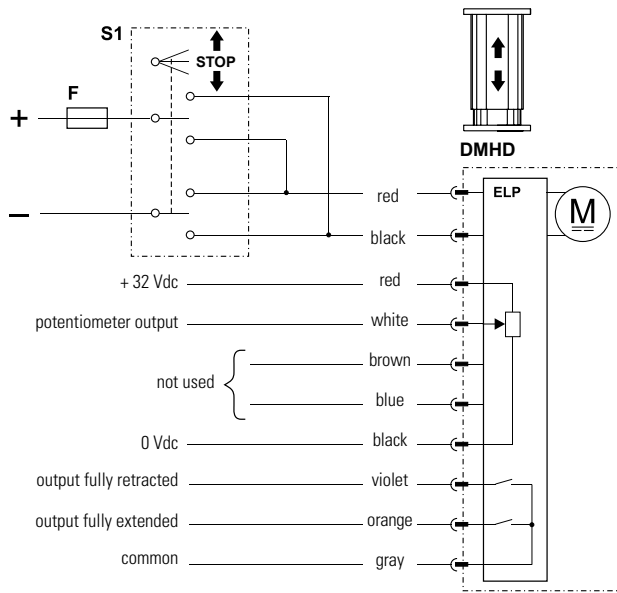

F Fuse  
S1 Double pole double throw switch

Control option ELP works as option EXP but also has two outputs that indicate when the extension tube is in its fully extended or retracted position.

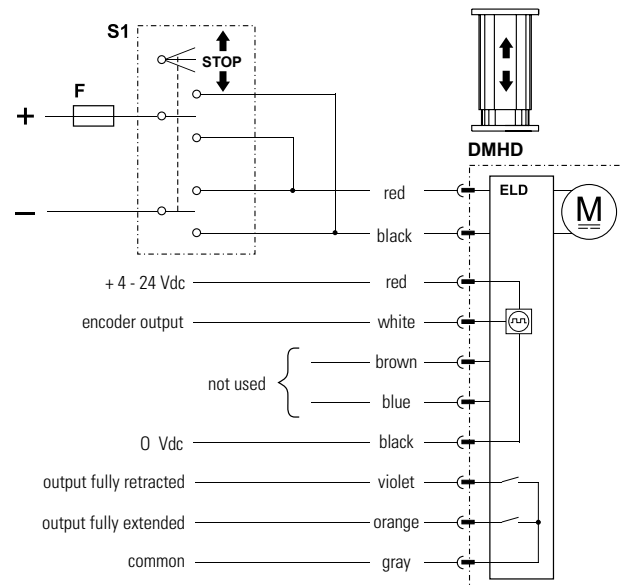

F Fuse  
S1 Double pole double throw switch

Control option ELD works as option EXD but also has two outputs that indicate when the extension tube is in its fully extended or retracted position.

# DMHD – Electrical Connections

## Option Type LXX

Actuator supply voltage	[Vdc]	9 - 16 DMHD12 DMHD24
Extend / retract input voltage	[Vdc]	9 - 32
Extend / retract input current	[mA]	6 - 22

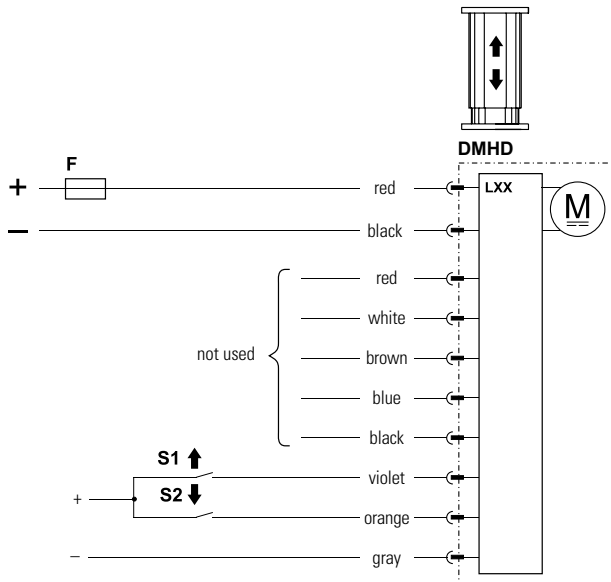

- F Fuse
- S1 Extend switch
- S2 Retract switch

Control option LXX has all the basic Electrak Monitoring Package features included in control option EXX, but the polarity of the motor voltage is switched by the onboard electronics instead. The customer-supplied switches used to command the actuator to extend or retract only need to handle low-level signals. However, the power supply and wiring that supply the actuator must be able to handle the motor current for the actuator model and load being used, as well as the inrush current (up to one and a half times the max. continuous current for the max. load being used for up to 150 milliseconds).

## Option Type LLX

Actuator supply voltage	[Vdc]	9 - 16 DMHD12 DMHD24
Output contact type		potential free
Max. switched output voltage	[Vdc]	140
Max. output current	[mA]	350
Max. output power	[W]	5
Extend / retract input voltage	[Vdc]	9 - 32
Extend / retract input current	[mA]	6 - 22

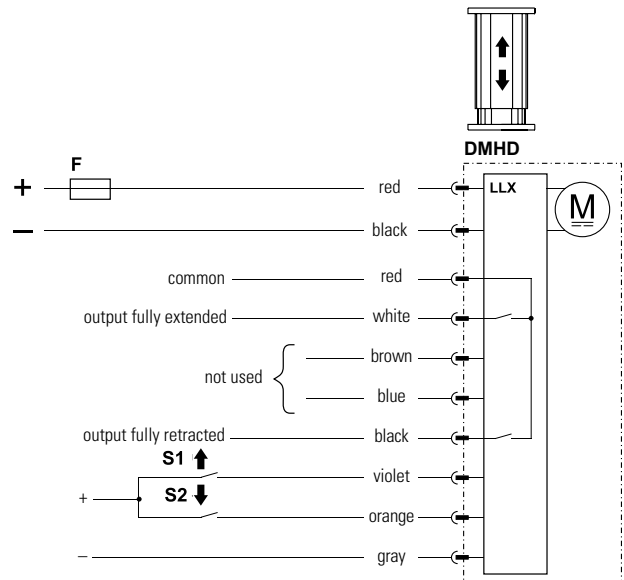

- F Fuse
- S1 Extend switch
- S2 Retract switch

Control option LLX works as option LXX but also has two outputs that indicate when the extension tube is in its fully extended or retracted position.

# DMHD – Electrical Connections

Option Type LXP		
Actuator supply voltage	[Vdc]	9 - 16 18 - 32
Potentiometer type		wire-wound
Potentiometer max. input voltage	[Vdc]	32
Potentiometer max. power	[W]	1
Potentiometer linearity	[%]	± 0.25
Potentiometer output resolution	[ohm/mm]	65.6 32.8 19.7 9.8
Extend / retract input voltage	[Vdc]	9 - 32
Extend / retract input current	[mA]	6 - 22

Option Type CNO		
Actuator supply voltage	[Vdc]	9 - 16 18 - 32
Command data includes:		<ul style="list-style-type: none"> <li>• position</li> <li>• speed</li> <li>• current</li> </ul>
Feedback data includes:		<ul style="list-style-type: none"> <li>• position</li> <li>• speed</li> <li>• current</li> <li>• other diagnostic information</li> </ul>

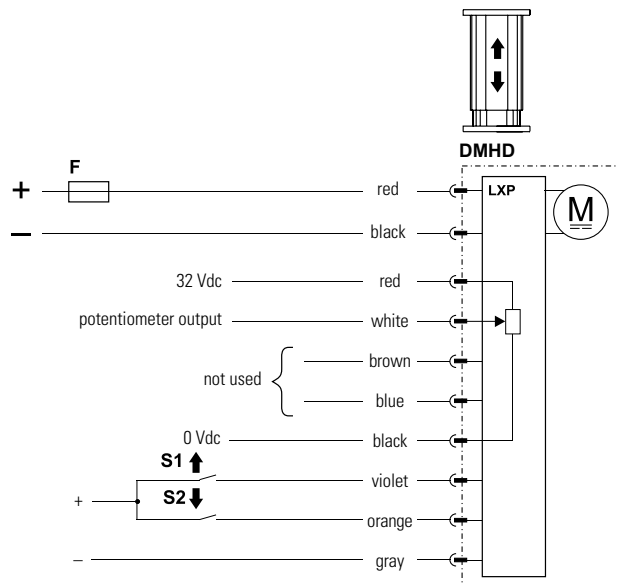

- F Fuse
- S1 Extend switch
- S2 Retract switch

Control option LXP works as option LXX but also has an analog (potentiometer) output that will provide feedback on the extension tube position.

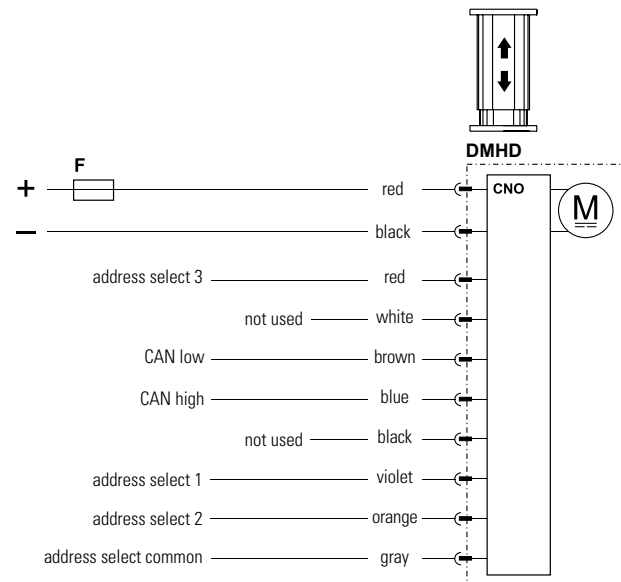

F Fuse

Control option CNO has a J1939 CAN bus control interface that controls and monitors the actuator. Extend and retract commands are sent via CAN messages on the CAN low and CAN high pins. Address select 1, 2 and 3 pins can be used as a BCD encoded adder to the default address. This can be used when multiple J1939 actuators are located on a single bus.

# DMHD – Electrical Connections

## Option Type SYN

Actuator supply voltage	[Vdc]	
DMHD12		9 - 16
DMHD24		18 - 32
Extend / retract input voltage	[Vdc]	9 - 32
Extend / retract input current	[mA]	6 - 22
Number of synchronized actuators		2 - 4
Max. actuator speed difference	[%]	25

Control option SYN works as option LXX but also has a synchronization feature, allowing two or more actuators having the SYN option to run in integrated motion.

Uneven loading is acceptable as long as no individual actuator is loaded beyond its rated load.

When using the low-level extend and retract inputs on the master actuator, the slave(s) will follow. If there is a need to run an actuator individually, it is possible to put it into an override state by closing a switch (S3) connected to the red lead as shown in the wiring diagram.

Note: Ensure that supply voltage to each actuator is within  $\pm 1$  volt.

Note: For units with the synchronization option, the speed at a given load is 25% lower than for those without. This is true irrespective of the unit being in synchronization or override mode, or simply run individually.

Note: Only two resistors are needed. They act as terminating resistors for the communication leads. One will be on the first unit of the bus, the other will be on the last.

- F Fuses
- S1 Extend switch
- S2 Retract switch
- S3 Override switch
- R Resistors 120 Ohm

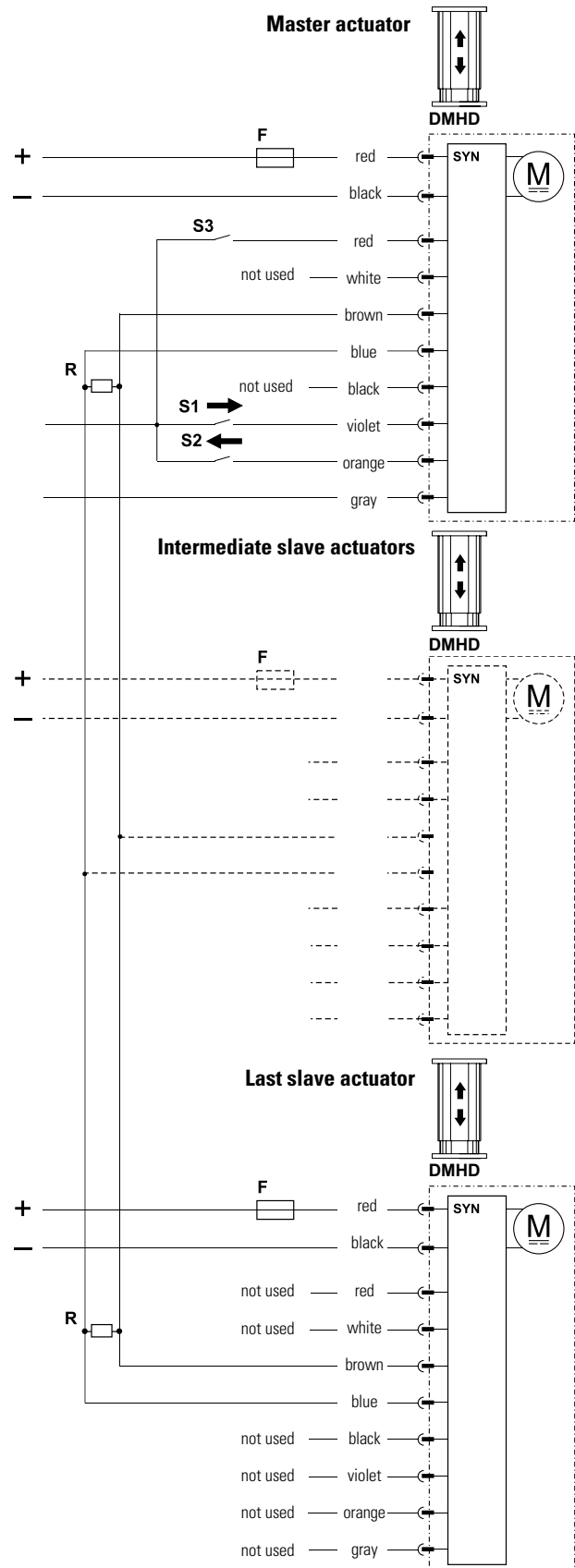

## DMHD – Accessories

### T-slot Bolt

Designation	Part Number
M10 T-slot bolt	D800041

The T-slot bolt fits in to the T-slot running along the outer profile of the lifting column. The T-slot bolts can be used to mount the unit instead of using the upper mounting plate, or/and for attaching other components to the profile.

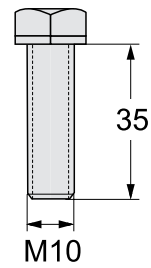

Dimensions

mm

## DMD – Technical Features



### Standard Features

- Self supporting column in extruded anodized aluminum with high load torque capability
- Onboard electronics with many optional functions
- 12 or 24 Vdc as standard input voltages
- Static load up to 18 kN (4000 lbf)
- Dynamic load up to 6.8 kN (1500 lbf)
- Stroke up to 24 inch
- Speed up to 71 mm/s (2.8 in/s)
- Protection class static IP65
- Rugged, robust and strong
- T-slot grooves along the entire profile
- Maintenance free

### General Specifications

Screw type	acme or ball
Nut type DMDxxxxA (acme screw) DMDxxxxB (ball screw)	self locking lead nut load lock ball nut
Manual override	no
Anti-rotation	yes
Static load holding brake acme screw ball screw	no (self-locking) yes
Safety features	overload clutch auto reset thermal switch
Electrical connections	cable with flying leads
Compliances	CE

### Optional Electrical Features

Potentiometer feedback

### Compatible Controls

Contact customer support at [www.thomsonlinear.com/cs](http://www.thomsonlinear.com/cs)



# DMD – Technical Specifications

Mechanical Specifications		
Max. static load <sup>(1)</sup>	[N (lbf)]	
DMDxxxxA (acme screw)		11350 (2500)
DMDxxxxB (ball screw)		18000 (4000)
Max. dynamic load (Fx)	[N (lbf)]	
DMDxx05A5		1100 (250)
DMDxx10A5		2250 (500)
DMDxx20A5		2250 (500)
DMDxx05B5		2250 (500)
DMDxx10B5		4500 (1000)
DMDxx20B5		4500 (1000)
DMDxx21B5		6800 (1500)
Max. load torque, dyn. and static	[Nm (lbf-in)]	
DMDxx-xxA (acme screw)		565 (5000)
DMDxx-xxB (ball screw)		710 (6284)
Speed @ no load/max. load	[mm/s (in/s)]	
DMDxx05A5		54/32 (2.10/1.20)
DMDxx10A5		30/18 (1.20/0.70)
DMDxx20A5		15/12 (0.67/0.45)
DMDxx05B5		61/37 (2.40/1.40)
DMDxx10B5		30/19 (1.30/0.80)
DMDxx20B5		15/12 0.60/0.45)
DMDxx21B5		15/11 (0.60/0.43)
Min. ordering stroke (S) length	[in]	4
Max. ordering stroke (S) length <sup>(2)</sup>	[in]	24
Ordering stroke length increments	[in]	2
Operating temperature limits	[°C (F)]	-25 – 65 (-15 – 150)
Full load duty cycle @ 25 °C (77 °F)	[%]	25
End play, maximum	[mm (in)]	1.0 (0.04)
Protection class - static		IP65

(1) Max. static load at fully retracted stroke

Electrical Specifications		
Available input voltages <sup>(1)</sup>	[Vdc]	12, 24
Input voltage tolerance	[%]	± 10
Current draw @ no load/max. load <sup>(2)</sup>	[A]	
DMD1205A5		12.0/34.0
DMD1210A5		7.0/27.0
DMD1220A5		5.0/15.0
DMD1205B5		7.0/27.0
DMD1210B5		5.0/25.0
DMD1220B5		4.0/13.0
DMD1221B5		4.0/20.0
DMD2405A5		6.0/17.0
DMD2410A5		4.0/13.0
DMD2420A5		2.0/7.5
DMD2405B5		4.0/14.0
DMD2410B5		2.0/12.5
DMD2420B5		2.0/7.5
DMD2421B5		2.0/10.0
Cable length	[mm (in)]	2000 (79)
Cable diameter	[mm (in)]	9 (0.35)
Cable leads cross section	[mm <sup>2</sup> (AWG)]	
motor leads		2.5 (10)
potentiometer leads		1 (17)

(1) For other input voltages - contact customer support.

(2) For current draw for 36 Vdc input voltage models - contact customer support.

# DMD – Dimensions

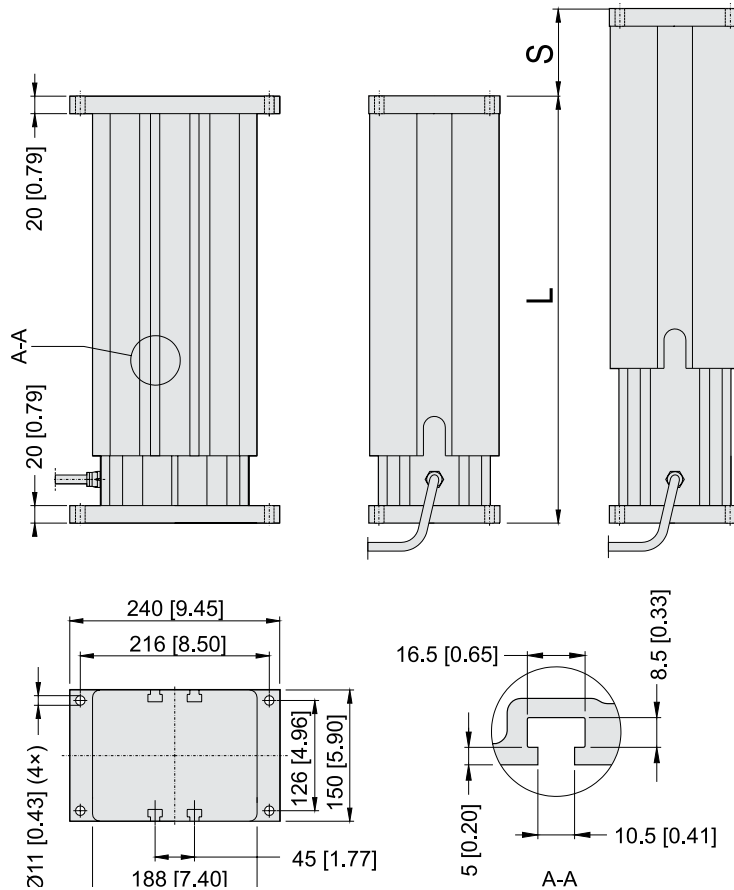

Dimensions	Projection
mm [inch]	

## Stroke, Retracted Length and Weight Relationships

Ordering stroke (S)	[in]	4	6	8	10	12	14	16	18	20	24
Retracted length, acme screw models (A)	[mm]	329.6	380.4	431.2	482.0	532.8	633.6	684.4	735.2	786.0	887.6
	[in]	13.0	15.0	17.0	19.0	21.0	24.9	26.9	28.9	30.9	34.9
Retracted length, ball screw models (A)	[mm]	369.6	420.4	471.2	522.0	572.8	673.6	724.4	775.2	826.2	927.6
	[in]	14.6	16.6	18.6	20.6	22.6	26.5	28.5	30.5	32.5	36.5
Add on length for option potentiometer	[mm]	55.0									
	[in]	2.17									
Weight, acme screw models	[kg]	18.7	20.2	21.6	23.1	24.6	27.3	28.7	30.2	31.7	34.6
	[lbf]	41.2	44.5	47.6	50.9	54.2	60.2	63.3	66.6	69.9	76.3
Weight, ball screw models	[kg]	20.4	21.9	23.4	24.8	26.3	29.0	30.4	31.9	33.4	36.3
	[lbf]	45.0	48.3	51.6	54.7	58.0	63.9	67.0	70.3	73.6	80.0
Add on weight for option potentiometer	[kg]	1.3									
	[lbf]	2.9									

# DMD – Performance Diagrams

Speed and Current vs. Load - Diagram 1

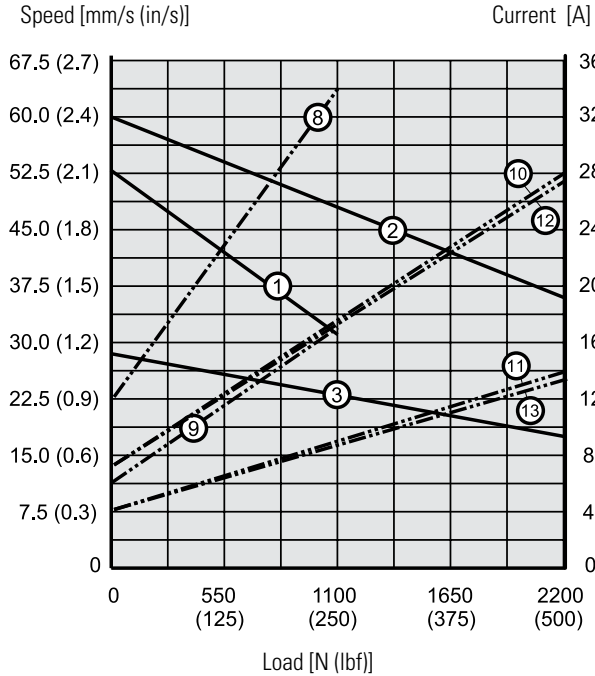

- |                               |                                 |
|-------------------------------|---------------------------------|
| <u>Speed Curves Diagram 1</u> | <u>Current Curves Diagram 1</u> |
| 1: DMDxx05A5                  | 8: DMD1205A5                    |
| 2: DMDxx05B5                  | 9: DMD2405A5                    |
| 3: DMDxx10A5                  | 10: DMD1205B5                   |
|                               | 11: DMD2405B5                   |
|                               | 12: DMD1210A5                   |
|                               | 13: DMD2410A5                   |

Speed and Current vs. Load - Diagram 2

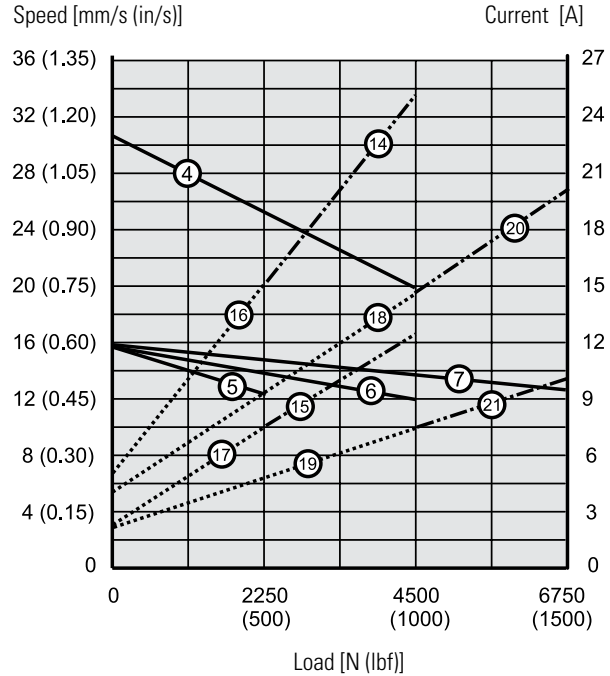

- |                               |                                 |
|-------------------------------|---------------------------------|
| <u>Speed Curves Diagram 2</u> | <u>Current Curves Diagram 2</u> |
| 4: DMDxx10B5                  | 14: DMD1210B5                   |
| 5: DMDxx20A5                  | 15: DMD2410B5                   |
| 6: DMDxx20B5                  | 16: DMD1220A5                   |
| 7: DMDxx21B5                  | 17: DMD2420A5                   |
|                               | 18: DMD1220B5                   |
|                               | 19: DMD2420B5                   |
|                               | 20: DMD1221B5                   |
|                               | 21: DMD2421B5                   |

Contact customer service for data on 36 Vdc models.

## Off Center Load Capacity

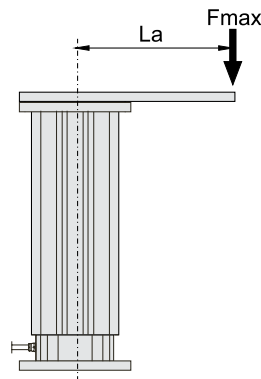
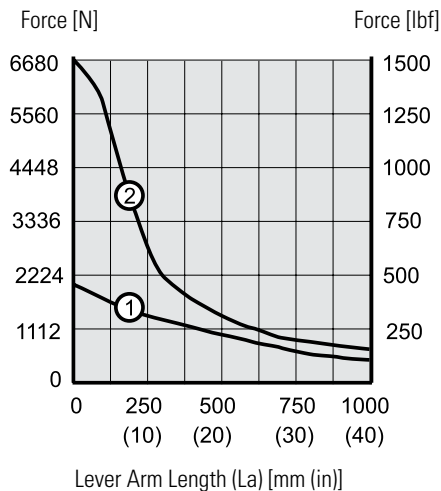

- 1: Acme screw models  
2: Ball screw models

## DMD – Ordering Key

Ordering Key			
1	2	3	4
DMD12	05A5-	10	PO
<p><b>1. Model and input voltage</b> DMD12 = lifting column type DMD, 12 Vdc DMD24 = lifting column type DMD, 24 Vdc</p> <p><b>2. Screw type, dynamic load capacity</b> 05A5 - = 1100 N, acme, 54 mm/s 10A5 - = 2250 N, acme, 30 mm/s 20A5 - = 2250 N, acme, 15 mm/s 05B5 - = 2250 N, ball, 61 mm/s 10B5 - = 4500 N, ball, 30 mm/s 20B5 - = 4500 N, ball, 15 mm/s 21B5 - = 6800 N, ball, 15 mm/s</p>		<p><b>3. Ordering stroke length <sup>(1)</sup></b> 04 = 4 inch (101.6 mm) 06 = 6 inch (152.4 mm) 08 = 8 inch (203.2 mm) 10 = 10 inch (254.0 mm) 12 = 12 inch (304.8 mm) 14 = 14 inch (355.6 mm) 16 = 16 inch (406.4 mm) 18 = 18 inch (457.2 mm) 20 = 20 inch (508.0 mm) 24 = 24 inch (609.6 mm)</p> <p><b>4. Options <sup>(2)</sup></b> PO = potentiometer</p> <p>(1) Other stroke lengths available upon request. Contact customer support. (2) Leave position blank for no option.</p>	

## DMD – Accessories

T-slot Bolt	
Designation	Part Number
M10 T-slot bolt	D800041

The T-slot bolt fits in to the T-slot running along the outer profile of the lifting column. The T-slot bolts can be used to mount the unit instead of using the upper mounting plate, or/and for attaching other components to the profile.

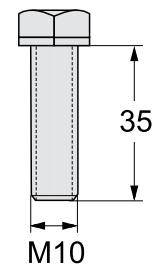

Dimensions
mm

# DMD – Electrical Connections

## Without Option

Actuator supply voltage	[Vdc]	
DMD12		12
DMD24		24

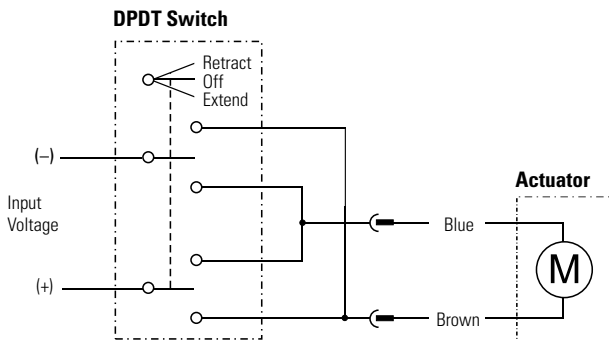

Connect the brown lead to positive and blue to negative to extend the actuator. Change polarity to retract the actuator.

## Option Potentiometer

Actuator supply voltage	[Vdc]	
DMD12		12
DMD24		24
Potentiometer type		wire-wound
Potentiometer max. input voltage	[Vdc]	32
Potentiometer max. power	[W]	2
Potentiometer linearity	[%]	± 0.25
Potentiometer output resolution	[ohm/mm]	
2 - 10 inch stroke		39
11 - 20 inch stroke		20
21 - 24 inch stroke		10

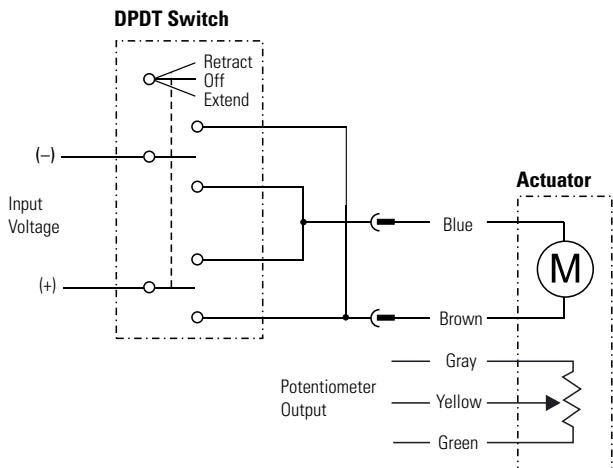

Connect the brown lead to positive and blue to negative to extend the actuator. Change polarity to retract the actuator. The potentiometer output has 0 ohm between gray and yellow when the actuator is fully extended.

## DMA – Technical Features



### Standard Features

- Self-supporting column in extruded anodized aluminium with high load torque capability
- Onboard electronics with many optional functions
- 1 × 230 or 3 × 400 Vac as standard input voltages
- Static load up to 18 kN (4000 lbf)
- Dynamic load up to 9 kN (2000 lbf)
- Stroke up to 24 inch
- Speed up to 71 mm/s (2.8 in/s)
- Protection class static IP45
- Rugged, robust and strong
- T-slot grooves along the entire profile
- Maintenance free

### General Specifications

Screw type	acme or ball
Nut type DMDxx-xxA (acme screw) DMDxx-xxB (ball screw)	self-locking lead nut load lock ball nut
Manual override	no
Anti-rotation	yes
Static load holding brake acme screw ball screw	no (self-locking) yes
Safety features	overload clutch auto reset thermal switch
Electrical connections	cable with flying leads
Compliances	CE

### Accessories

T-slot bolts

### Compatible Controls

Contact customer support at [www.thomsonlinear.com/cs](http://www.thomsonlinear.com/cs)

# DMA – Technical Specifications

Mechanical Specifications		
Max. static load <sup>(1)</sup>	[N (lbf)]	
DMAxxxxA (acme screw)		11350 (2500)
DMAxxxxB (ball screw)		18000 (4000)
Max. dynamic load (Fx)	[N (lbf)]	
DMAxx05A5		1100 (250)
DMAxx10A5		2250 (500)
DMAxx20A5		2250 (500)
DMAxx05B5		2250 (500)
DMAxx10B5		4500 (1000)
DMAxx20B5		4500 (1000)
DMAxx21B5		6800 (1500)
Max. load torque, dyn. and static	[Nm (lbf-in)]	
DMAxxxxA (acme screw)		565 (5000)
DMAxxxxB (ball screw)		710 (6284)
Speed @ no load/max. load	[mm/s (in/s)]	
DMAxx05A5		54/32 (2.10/1.20)
DMAxx10A5		30/18 (1.20/0.70)
DMAxx20A5		15/12 (0.67/0.45)
DMAxx05B5		61/37 (2.40/1.40)
DMAxx10B5		30/19 (1.30/0.80)
DMAxx20B5		15/12 (0.60/0.45)
DMAxx21B5		15/11 (0.60/0.43)
Min. ordering stroke (S) length	[in]	4
Max. ordering stroke (S) length	[in]	24
Ordering stroke length increments	[in]	2
Operating temperature limits	[°C (F)]	-25 – 65 (-15 – 150)
Max. on time	[s]	45
Full load duty cycle @ 25 °C (77 °F)	[%]	25
End play, maximum	[mm (in)]	1.0 (0.04)
Protection class - static, standard (optional)		IP45

(1) Max. static load at fully retracted stroke

Electrical Specifications		
Available input voltages	[Vac]	1 × 230 <sup>(1)</sup> 3 × 400
Input voltage tolerance	[%]	± 10
Current draw @ no load/max. load	[A]	
DMA2205A5		1.10/1.55
DMA2210A5		0.85/1.30
DMA2220A5		0.95/1.25
DMA2205B5		0.85/1.30
DMA2210B5		0.85/1.30
DMA2220B5		0.85/1.30
DMA2221B5		0.85/1.25
DMA4205A5		not possible
DMA4210A5		0.35/0.60
DMA4220A5		0.30/0.35
DMA4205B5		0.35/0.55
DMA4210B5		0.30/0.50
DMA4220B5		0.30/0.35
DMA4221B5		0.30/0.45
Cable length	[mm (in)]	0.6 (24)
Cable diameter	[mm (in)]	9 (0.35)
Cable leads cross section	[mm <sup>2</sup> (AWG)]	2.5 (14)

(1) Capacitor 10 µF ( p/n 9200-448-003) required to run the actuator.

# DMA – Dimensions

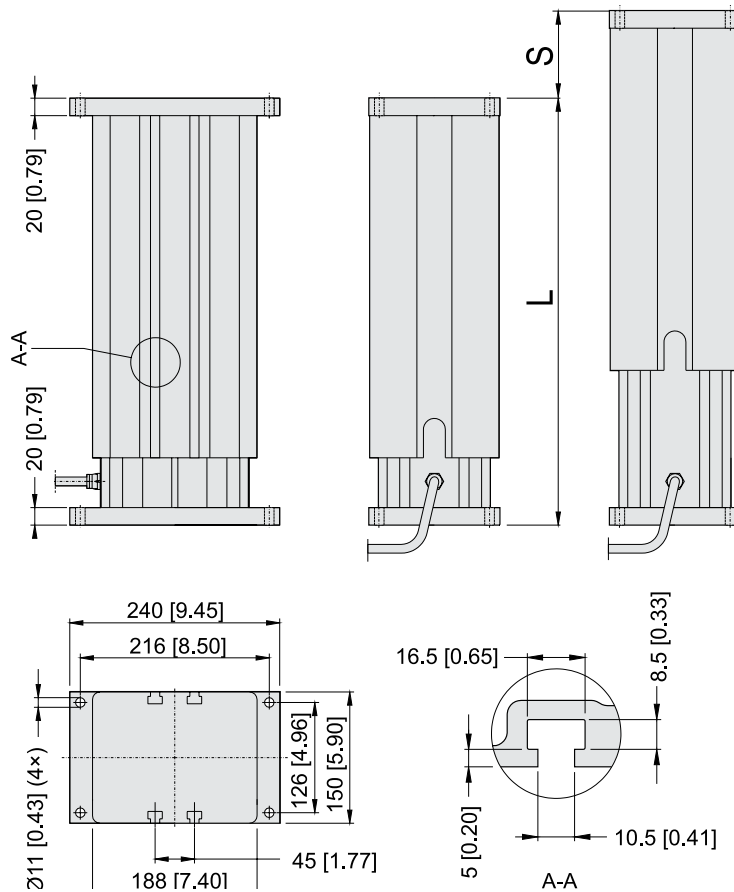

Dimensions	Projection
mm [inch]	

## Stroke, Retracted Length and Weight Relationships

Ordering stroke (S)	[in]	4	6	8	10	12	14	16	18	20	24
Retracted length, acme screw models (A)	[mm]	329.6	380.4	431.2	482.0	532.8	633.6	684.4	735.2	786.0	887.6
	[in]	13.0	15.0	17.0	19.0	21.0	24.9	26.9	28.9	30.9	34.9
Retracted length, ball screw models (A)	[mm]	369.6	420.4	471.2	522.0	572.8	673.6	724.4	775.2	826.2	927.6
	[in]	14.6	16.6	18.6	20.6	22.6	26.5	28.5	30.5	32.5	36.5
Weight, acme screw models	[kg]	20.9	22.4	23.8	25.3	26.8	29.5	30.9	32.4	33.9	36.8
	[lbf]	46.1	49.4	52.5	55.8	59.1	65.0	68.1	71.4	74.7	81.1
Weight, ball screw models	[kg]	22.6	24.1	25.6	27.0	28.5	31.2	32.6	34.1	35.6	38.6
	[lbf]	49.8	53.1	56.4	59.5	62.8	68.8	71.9	75.2	78.5	85.1



# DMA – Performance Diagrams

Speed and Current vs. Load - Diagram 1

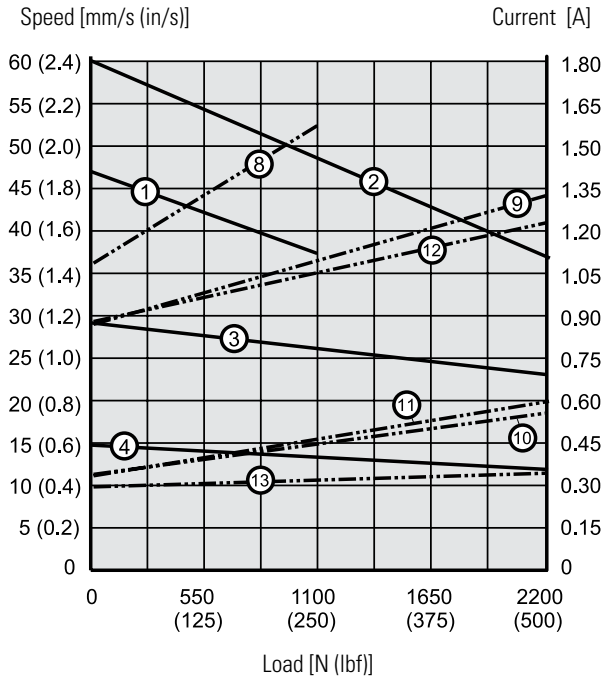

Speed and Current vs. Load - Diagram 2

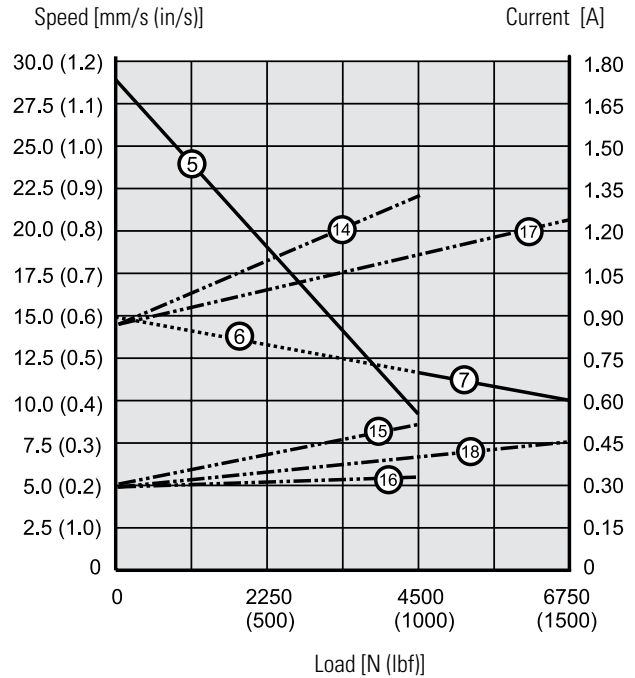

Speed Curves Diagram 1

- 1: DMA2205A5
- 2: DMAxx05B5
- 3: DMAxx10A5
- 4: DMAxx20A5

Current Curves Diagram 1

- 8: DMA2205A5
- 9: DMA2205B5(10A5)
- 10: DMA4205B5
- 11: DMA4210A5
- 12: DMA2220A5
- 13: DMA4220A5

Speed Curves Diagram 2

- 5: DMAxx10B5
- 6: DMAxx20B5
- 7: DMAxx21B5

Current Curves Diagram 2

- 14: DMA2210B5(20B5)
- 15: DMA4210B5
- 16: DMA2220B5
- 17: DMA2221B5
- 18: DMA4221B5

Off Center Load Capacity

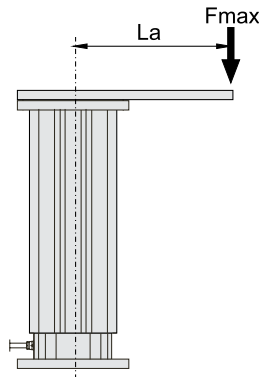
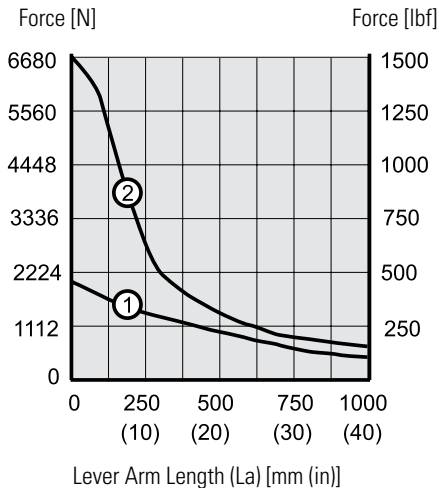

- 1: Acme screw models
- 2: Ball screw models

## DMA – Ordering Key

Ordering Key		
1	2	3
<b>DMA22</b>	<b>05A5-</b>	<b>10</b>
<b>1. Model and input voltage</b> DMA22 = lifting column type DMA, 1 × 230 Vac DMA42 = lifting column type DMA, 3 × 400 Vac  <b>2. Screw type, dynamic load capacity</b> 05A5 - = 1100 N, acme, 54 mm/s 10A5 - = 2250 N, acme, 30 mm/s 20A5 - = 2250 N, acme, 15 mm/s 05B5 - = 2250 N, ball, 61 mm/s 10B5 - = 4500 N, ball, 30 mm/s 20B5 - = 4500 N, ball, 15 mm/s 21B5 - = 6800 N, ball, 15 mm/s		<b>3. Ordering stroke length <sup>(1)</sup></b> 04 = 4 inch (101.6 mm) 06 = 6 inch (152.4 mm) 08 = 8 inch (203.2 mm) 10 = 10 inch (254.0 mm) 12 = 12 inch (304.8 mm) 14 = 14 inch (355.6 mm) 16 = 16 inch (406.4 mm) 18 = 18 inch (457.2 mm) 20 = 20 inch (508.0 mm) 24 = 24 inch (609.6 mm)  (1) Other stroke lengths available upon request. Please contact customer support. (2) Leave position blank for no option.

## DMA – Accessories

T-slot Bolt	
Designation	Part Number
M10 T-slot bolt	D800041

The T-slot bolt fits in to the T-slot running along the outer profile of the lifting column. The T-slot bolts can be used to mount the unit instead of using the upper mounting plate, or/and for attaching other components to the profile.

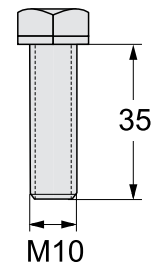

Dimensions
mm

# DMA – Electrical Connections

## Input Voltage 230 Vac

Actuator supply voltage DMA22	[Vac]	1 × 230
----------------------------------	-------	---------

### Acme screw models (no anti-coast brake)

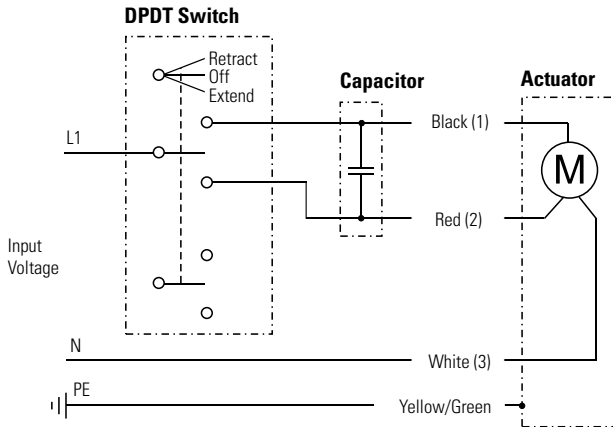

### Ball screw models (with anti-coast brake)

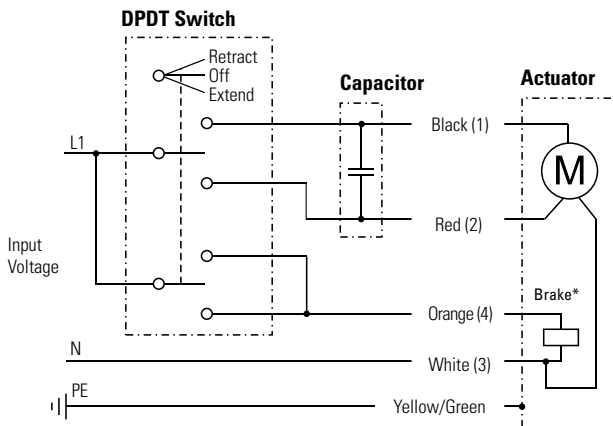

Leads can be either color or number marked. To be able to run the actuator, a 10  $\mu$ F capacitor must be connected between black (1) and red (2) leads. See page 54 for ordering of capacitors. Connect black (1) lead to L1 and white (3) lead to N (neutral) to retract the actuator. Change L1 from lead black (1) to lead red (2) to extend the actuator. Ball screw models have an anti-coast brake\*, that must be released during motion, which is done by connecting orange (4) lead to L1. Acme models do not have any anti-coast brake.

## Input Voltage 400 Vac

Actuator supply voltage DMA42	[Vac]	3 × 400
----------------------------------	-------	---------

### Acme screw models (no anti-coast brake)

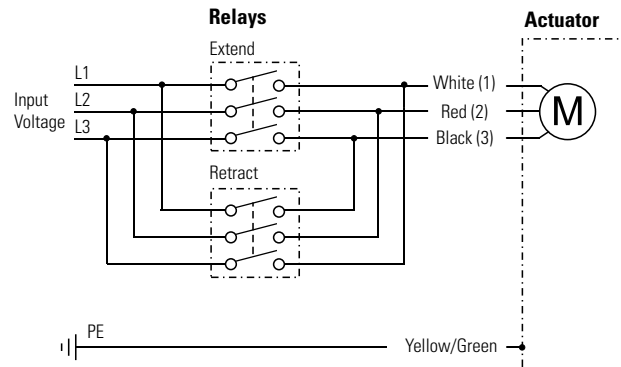

### Ball screw models (with anti-coast brake)

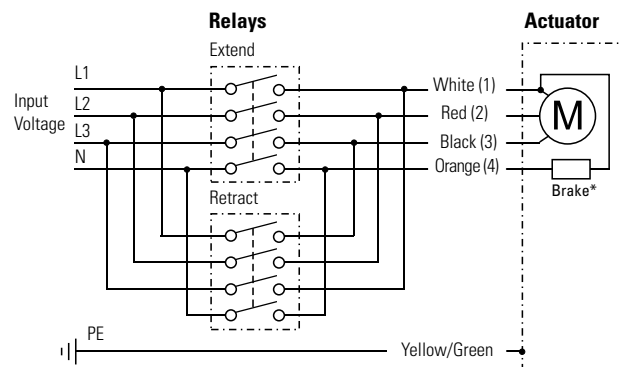

Leads can be either color or number marked. Connect white (1) lead to L1, red (2) lead to L2 and black (3) lead to L3 to extend the actuator. Change the places of white (2) lead and black (3) to retract the actuator. Ball screw models have an anti-coast brake\*, that must be released during motion, which is done by connecting orange (4) to N (neutral). Acme models do not have any anti-coast brake.

## LM80-H – Technical Features



### Standard Features

- Rodless actuator for horizontal operation
- For use in domestic, office or medical applications
- Rigid, self-supporting extruded aluminium profile
- Durable and corrosion free
- Lightweight with quiet operation
- Safety nut on ball screw versions
- Easy and fast T-slot mounting
- Maintenance free

### General Specifications

Screw type	trapezoidal or ball
Nut type trapezoidal screw ball screw	polymer lead nut load lock ball nut
Manual override	no
Anti-rotation	yes
Static load holding brake	no
Safety features	spring loaded soft stop
Electrical connections with motor enclosure without motor enclosure	cable with connector cable clips directly on motor
Compliances	CE

### Optional Mechanical Features

No motor enclosure
Manual override
Alternative motor positions
Special stroke or stroke over 1500 mm (contact customer support)

### Optional Electrical Features

Encoder feedback (contact customer support)
---

### Accessories

T-slot mounting kit
---------------------

### Compatible Controls

Contact customer support at <a href="http://www.thomsonlinear.com/cs">www.thomsonlinear.com/cs</a>
--

# LM80-H – Technical Specifications

Mechanical Specifications		
Max. load (Fb) <sup>(1)</sup>	[N (lbf)]	2000 (450)
Max. load torque (Mb) <sup>(1)</sup>	[N (lbf)]	
DTxx-T68M xxxxx H		250 (56)
DTxx -B61M xxxxx H		400 (90)
DTxx -B62M xxxxx H		180 (40)
DTxx -B65M xxxxx H		750 (169)
Speed @ no load/max. load	[mm/s (in/s)]	
DTxx-T68M xxxxx H		44/37 (1.7/1.5)
DTxx -B61M xxxxx H		55/50 (2.2/2.0)
DT12 -B62M xxxxx H		110/73 (4.3/2.9)
DT24 -B62M xxxxx H		11/87 (0.4/3.4)
DTxx -B65M xxxxx H		28/28 (1.1/1.1)
Min. ordering stroke (S) length <sup>(2)</sup>	[mm]	500
Max. ordering stroke (S) length <sup>(2)</sup>	[mm]	1500
Ordering stroke length increments <sup>(2)</sup>	[mm]	100
Operating temperature limits	[°C (F)]	0 – 40 (32 – 104)
Full load duty cycle @ 20 °C (68 °F)	[%]	15
End play, maximum	[mm (in)]	1.0 (0.04)
Protection class - static		
with motor enclosure		IP44
without motor enclosure		IP33

(1) See below for definition of forces.

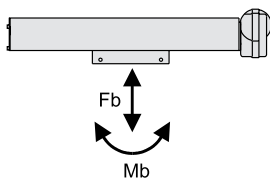

(2) For other stroke lengths, contact customer support.

Electrical Specifications		
Available input voltages	[Vdc]	
DT12		12
DT24		24
Input voltage tolerance	[%]	± 10
Current draw @ no load/max. load	[A]	
DT12-T68MxxxxxH		5.5/6.0
DT24-T(B)68(1)MxxxxxH		3.0/5.0
DT12-B61MxxxxxH		6.0/8.0
DT12-B62MxxxxxH		6.0/15.0
DT24-B62MxxxxxH		3.0/7.0
DT12-B65MxxxxxH		5.8/5.8
DT24-B65MxxxxxH		2.8/2.8
Motor cable length	[m (in)]	
with motor enclosure		2000 (79)
without motor enclosure		-
Motor cable diameter	[mm (in)]	
with motor enclosure		5.7 (0.22)
without motor enclosure		-
Motor cable leads cross section	[mm <sup>2</sup> (AWG)]	
with motor enclosure		1.5 (16)
without motor enclosure		-

# LM80-H – Dimensions

**!** Note: this unit may only be mounted horizontally

Dimensions	Projection
mm [inch]	

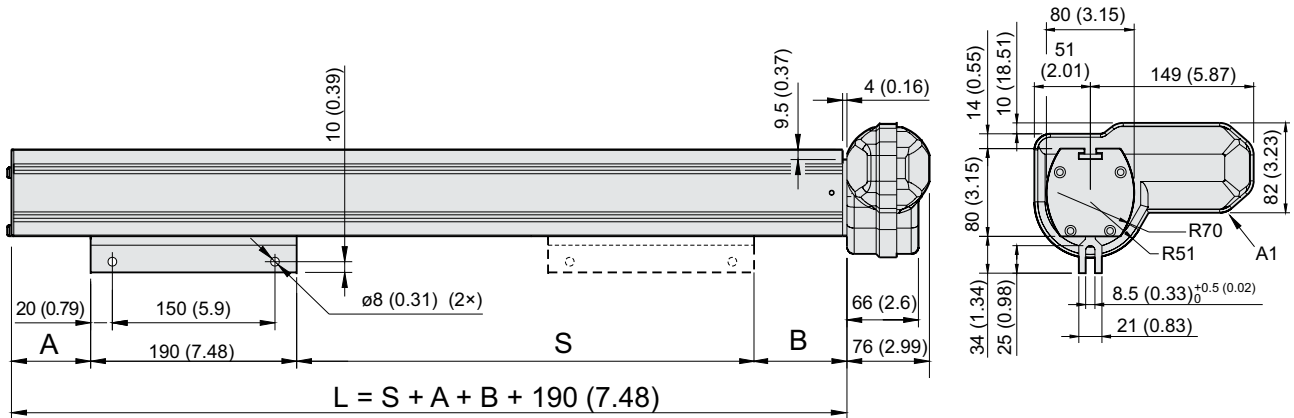

S: stroke  
L: length of profile  
A1: motor shown in position A (standard position)

## Stroke, Profile Length and Weight Relationships

Ordering stroke (S)	[mm]	500	600	700	800	900	1000	1100	1200	1300	1400	1500
Dimension (A) / (B) DTxx -T68M xxxxx H	[mm]	54.0 / 77.0										
	[in]	2.1 / 3.0										
Dimension (A) / (B) DTxx -B61M xxxxx H	[mm]	102.0 / 77.0										
	[in]	4.0 / 3.0										
Dimension (A) / (B) DTxx -B62M xxxxx H	[mm]	102.0 / 77.0										
	[in]	4.0 / 3.0										
Dimension (A) / (B) DTxx -B65M xxxxx H	[mm]	79.0 / 77.0										
	[in]	1.9 / 3.0										
Weight DTxx -T68M xxxxx H	[kg]	11.2	13.1	14.8	16.6	18.1	20.2	22.0	23.8	25.5	27.4	29.1
	[lbf]	24.6	28.8	32.6	36.5	39.8	44.4	48.4	52.36	56.1	60.3	64.0
Weight DTxx -B61M xxxxx H	[kg]	12.1	13.9	15.7	17.5	19.3	21.0	22.9	24.6	26.3	28.2	30.0
	[lbf]	30.3	30.6	34.5	38.5	42.7	46.2	50.4	54.1	57.9	62.0	66.0
Weight DTxx -B62M xxxxx H	[kg]	12.1	13.9	15.7	17.5	19.3	21.0	22.9	24.6	26.3	28.2	30.0
	[lbf]	30.3	30.6	34.5	38.5	42.7	46.2	50.4	54.1	57.9	62.0	66.0
Weight DTxx -B65M xxxxx H	[kg]	11.7	13.5	15.3	17.1	18.9	20.6	22.4	24.2	26.0	27.8	29.6
	[lbf]	25.7	29.7	33.7	37.6	41.6	45.3	49.3	53.2	57.2	61.2	65.1

# LM80-H – Performance Diagrams

## Speed and Current vs. Load

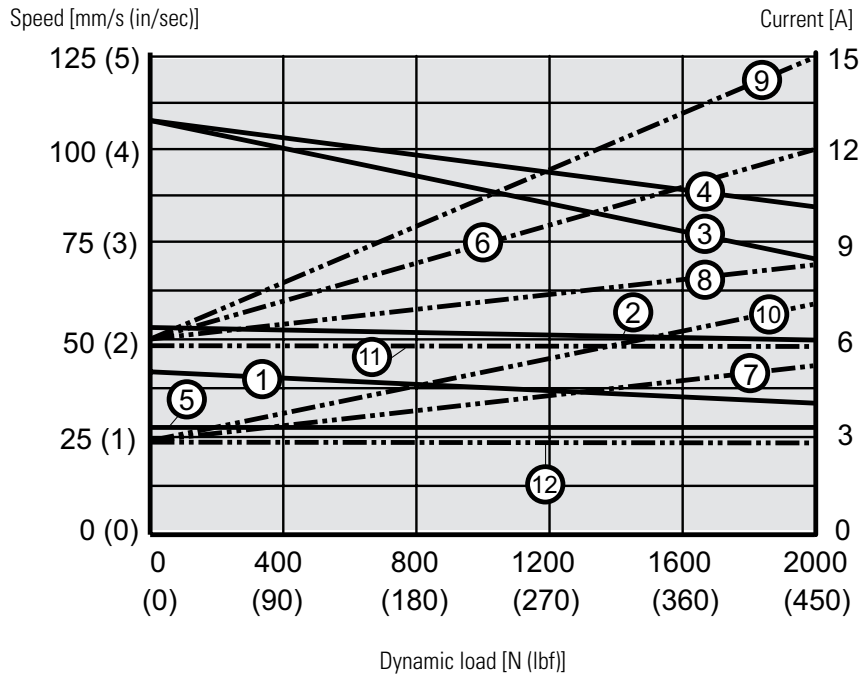

Speed

- 1: DTxx-T68MxxxxxH
- 2: DTxx-B61MxxxxxH
- 3: DT12-B62MxxxxxH
- 4: DT24-B62MxxxxxH
- 5: DTxx-B65MxxxxxH

Current

- 6: DT12-T68MxxxxxH
- 7: DT24-T(B)68(1)MxxxxxH
- 8: DT12-B61MxxxxxH
- 9: DT12-B62MxxxxxH
- 10: DT24-B62MxxxxxH
- 11: DT12-B65MxxxxxH
- 12: DT24-B65MxxxxxH

## Maximum Permissible Deflection of Profile

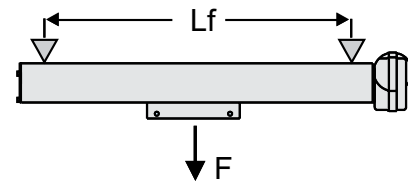
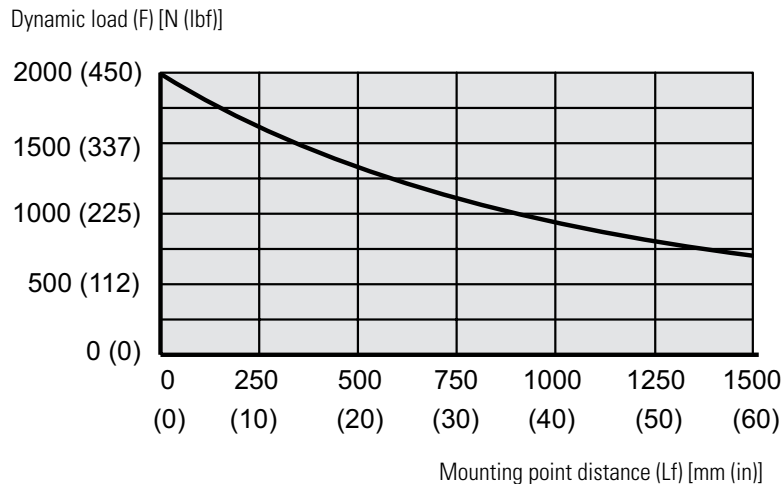

# LM80-H – Ordering Key

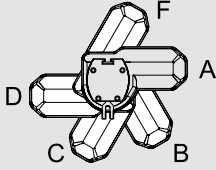
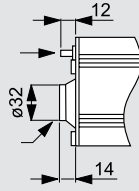
Ordering Key						
1	2	3	4	5	6	7
<b>DT12-</b>	<b>B62M-</b>	<b>100</b>	<b>A</b>	<b>C</b>	<b>H</b>	<b>X</b>
<p><b>1. Model and input voltage</b> DT12 - = LM80, 12 Vdc DT24 - = LM80, 24 Vdc</p> <p><b>2. Load torque capacity and screw type</b> T68M - = 250 N (56 lbf), trapezoidal screw B61M - = 400 N (90 lbf), ball screw B62M - = 180 N (40 lbf), ball screw B65M - = 750 N (169 lbf), ball screw</p> <p><b>3. Ordering stroke length</b> 050 = 500 mm 060 = 600 mm 070 = 700 mm 080 = 800 mm 090 = 900 mm 100 = 1000 mm 110 = 1100 mm 120 = 1200 mm 130 = 1300 mm 140 = 1400 mm 150 = 1500 mm</p>			<p><b>4. Motor orientation</b> A = 0° (standard) B = 60° C = 120° D = 180° F = 300°</p>  <p><b>5. Motor enclosure</b> C = with enclosure (IP44) U = no enclosure (IP33)</p> <p><b>6. Mounting orientation</b> H = horizontal</p> <p><b>7. Options</b> X = no option H = manual override <sup>(1)</sup></p> <p>(1) Manual override dimensions</p>  <p>Hexagon socket with plastic cover (4 mm Allen key included)</p>			

# LM80-H – Accessories

## T-slot Mounting Kit

Designation	Part Number
M8 T-slot mounting kit	D680507

The T-slot mounting kit consists of four T-slot bolts, washers and nuts that fit in to the T-slot running along the profile. The T-slot mounting kit can be used to mount the unit or/and for attaching other components to the profile.

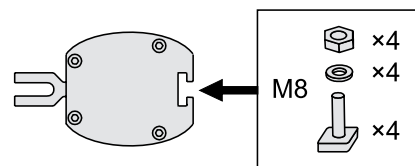



# LM80-H – Electrical Connections

## Without Option (standard)

Actuator supply voltage	[Vdc]	
DT12		12
DT24		24

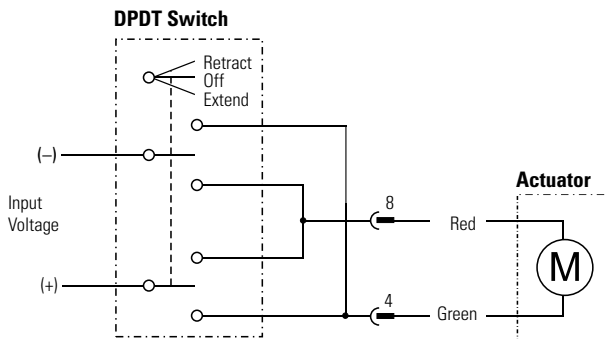

### Connector pin configuration (front view)

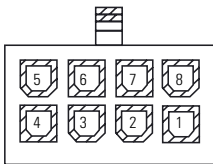

Connect the green lead (connector pin 4) to positive and red (pin 8) to negative to extend the actuator. Change polarity to retract the actuator.

## LM80-V – Technical Features



### Standard Features

- Rodless actuator for vertical operation with motor down
- For use in domestic, office or medical applications
- Rigid, self-supporting extruded aluminium profile
- Durable and corrosion free
- Holding brake prevents downward motion at power off
- Lightweight with quiet operation
- Safety nut on ball screw versions
- Easy and fast T-slot mounting
- Optional spline safety function
- Maintenance free

### General Specifications

Screw type	trapezoidal or ball
Nut type trapezoidal screw ball screw	polymer lead nut load lock ball nut
Manual override	no
Anti-rotation	yes
Static load holding brake	yes
Safety features	spring loaded soft stop
Electrical connections with motor enclosure without motor enclosure	cable with connector cable clips directly on motor
Compliances	CE

### Optional Mechanical Features

No motor enclosure
Manual override
Alternative motor positions
Spline safety function
Special stroke or stroke over 1500 mm (contact customer support)

### Optional Electrical Features

Encoder feedback (contact customer support)
---

### Accessories

T-slot mounting kit
---------------------

### Compatible Controls

Contact customer support at <a href="http://www.thomsonlinear.com/cs">www.thomsonlinear.com/cs</a>
--

# LM80-V – Technical Specifications

Mechanical Specifications		
Max. load (Fa) <sup>(1)</sup>	[N (lbf)]	
DTxx-T68MxxxxV(F)		650 (146)
DTxx-B61MxxxxV(F)		1000 (225)
DTxx-B62MxxxxV(F)		450 (101)
DTxx-B65MxxxxV(F)		2000 (450)
Max. load torque (Ma) <sup>(1)</sup>	[N (lbf)]	
DTxx-T68MxxxxV(F)		250 (56)
DTxx-B61MxxxxV(F)		400 (90)
DTxx-B62MxxxxV(F)		180 (40)
DTxx-B65MxxxxV(F)		750 (169)
Speed @ no load/max. load	[mm/s (in/s)]	
DT12-T68MxxxxV(F)		44/29 (1.7/1.1)
DT24-T68MxxxxV(F)		44/35 (1.7/1.4)
DT12-B61MxxxxV(F)		55/37 (2.2/1.5)
DT24-B61MxxxxV(F)		55/43 (2.2/1.7)
DT12-B62MxxxxV(F)		110/67 (4.3/2.6)
DT24-B62MxxxxV(F)		110/83 (4.3/3.3)
DT12-B65MxxxxV(F)		28/19 (1.1/0.7)
DT24-B65MxxxxV(F)		28/22 (1.1/0.9)
Min. ordering stroke (S) length <sup>(2)</sup>	[mm]	500
Max. ordering stroke (S) length <sup>(2)</sup>	[mm]	1500
Ordering stroke length increments <sup>(2)</sup>	[mm]	100
Operating temperature limits	[°C (F)]	0 – 40 (32 – 104)
Full load duty cycle @ 20 °C (68 °F)	[%]	15
Maximum on time	[s]	120
Protection class - static		
with motor enclosure		IP44
without motor enclosure		IP33

Electrical Specifications		
Available input voltages	[Vdc]	
DT12		12
DT24		24
Input voltage tolerance	[%]	± 10
Current draw @ no load/max. load	[A]	
DT12-T68MxxxxV(F)		6.3/17.0
DT24-T68MxxxxV(F)		3.0/6.0
DT12-B61MxxxxV(F)		6.3/17.0
DT24-B61MxxxxV(F)		3.0/6.0
DT12-B62MxxxxV(F)		6.3/17.0
DT24-B62MxxxxV(F)		3.0/6.0
DT12-B65MxxxxV(F)		6.3/17.0
DT24-B65MxxxxV(F)		3.0/6.0
Motor cable length	[m (in)]	
with motor enclosure		2000 (79)
without motor enclosure		-
Motor cable diameter	[mm (in)]	
with motor enclosure		5.7 (0.22)
without motor enclosure		-
Motor cable leads cross section	[mm <sup>2</sup> (AWG)]	
with motor enclosure		1.5 (16)
without motor enclosure		-

(1) See below for definition of forces.

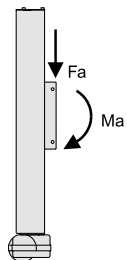

(2) For other stroke lengths, contact customer support.

# LM80-V – Dimensions

**!** Note: this unit may only be mounted vertically with the motor down even if drawing shows it horizontally

Dimensions	Projection
mm [inch]	

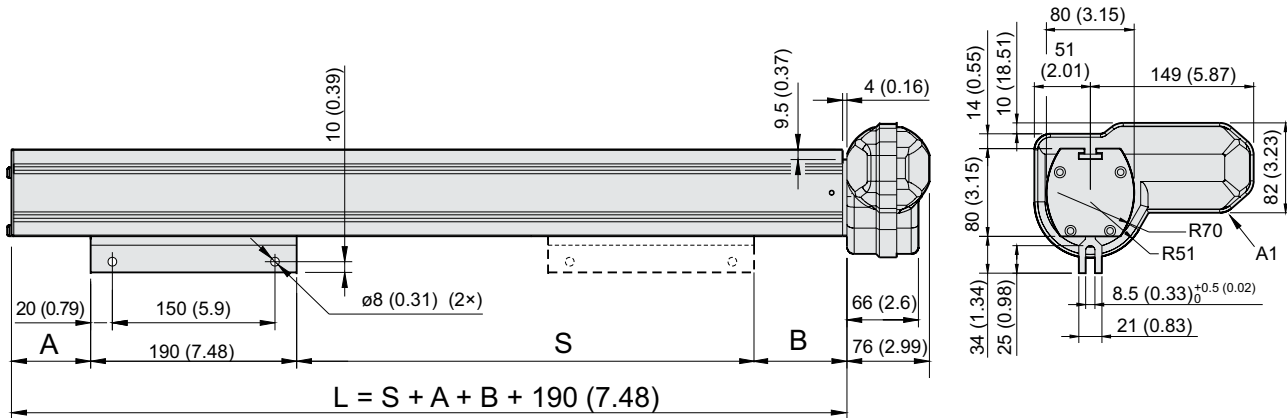

S: stroke  
L: length of profile  
A1: motor shown in position A (standard position)

## Stroke, Profile Length and Weight Relationships

Ordering stroke (S)	[mm]	500	600	700	800	900	1000	1100	1200	1300	1400	1500
Dimension (A) / (B)	[mm]	50.0 / 71.0 (50.0 / 90.0)										
DTxx -T68M xxxxx V(F)	[in]	2.0 / 2.8 ( 2.0 / 3.5)										
DTxx -B61M xxxxx V(F)	[mm]	53.0 / 120.0 (53.0 / 144.0)										
Dimension (A) / (B)	[in]	2.1 / 4.7 (2.1 / 5.7)										
DTxx -B62M xxxxx V(F)	[mm]	53.0 / 120.0 (53.0 / 144.0)										
Dimension (A) / (B)	[in]	2.1 / 4.7 (2.1 / 5.7)										
DTxx -B65M xxxxx V(F)	[mm]	53.0 / 97.0 (53.0 / 126.0)										
Dimension (A) / (B)	[in]	2.1 / 3.8 (2.1 / 5.0)										
Weight	[kg]	11.1	12.9	14.7	16.5	18.2	20.0	21.8	23.6	25.4	27.2	28.9
DTxx -T68M xxxxx V(F)	[lbf]	(11.6)	(13.4)	(15.2)	(17.0)	(18.7)	(20.5)	(22.3)	(24.1)	(25.9)	(27.7)	(29.4)
	[kg]	24.2	28.4	32.3	36.3	40.0	44.0	48.0	51.9	55.9	59.8	63.6
	[lbf]	(25.5)	(29.5)	(33.4)	(37.4)	(41.1)	(45.1)	(49.0)	(53.0)	(57.0)	(60.9)	(64.7)
Weight	[kg]	11.6	13.4	15.2	17.0	18.7	20.5	22.3	24.1	25.9	27.7	29.5
DTxx -B61M xxxxx V(F)	[lbf]	(12.1)	(13.9)	(15.7)	(17.5)	(19.2)	(21.0)	(22.8)	(24.6)	(26.4)	(28.2)	(30.0)
	[kg]	25.5	29.5	33.4	37.4	41.1	45.1	52.4	53.0	57.0	61.0	64.9
	[lbf]	(26.6)	(30.6)	(34.5)	(38.5)	(42.2)	(46.2)	(50.2)	(54.1)	(58.1)	(62.0)	(66.0)
Weight	[kg]	11.6	13.4	15.2	17.0	18.7	20.5	22.3	24.1	25.9	27.7	29.5
DTxx -B62M xxxxx V(F)	[lbf]	(12.1)	(13.9)	(15.7)	(17.5)	(19.2)	(21.0)	(22.8)	(24.6)	(26.4)	(28.2)	(30.0)
	[kg]	25.5	29.5	33.4	37.4	41.1	45.1	52.4	53.0	57.0	61.0	64.9
	[lbf]	(26.6)	(30.6)	(34.5)	(38.5)	(42.2)	(46.2)	(50.2)	(54.1)	(58.1)	(62.0)	(66.0)
Weight	[kg]	12.0	13.8	15.6	17.6	19.3	21.1	22.9	24.7	26.5	28.2	30.1
DTxx -B65M xxxxx V(F)	[lbf]	(12.5)	(14.3)	(16.1)	(18.1)	(19.8)	(21.6)	(23.4)	(25.2)	(27.0)	(28.7)	(30.6)
	[kg]	26.4	30.4	34.3	38.7	42.5	46.4	50.4	54.3	58.3	62.0	66.2
	[lbf]	(27.5)	(31.5)	(35.4)	(39.8)	(43.6)	(47.5)	(51.5)	(55.4)	(59.4)	(63.1)	(67.3)

# LM80-V – Performance Diagrams

Speed and Current vs. Load

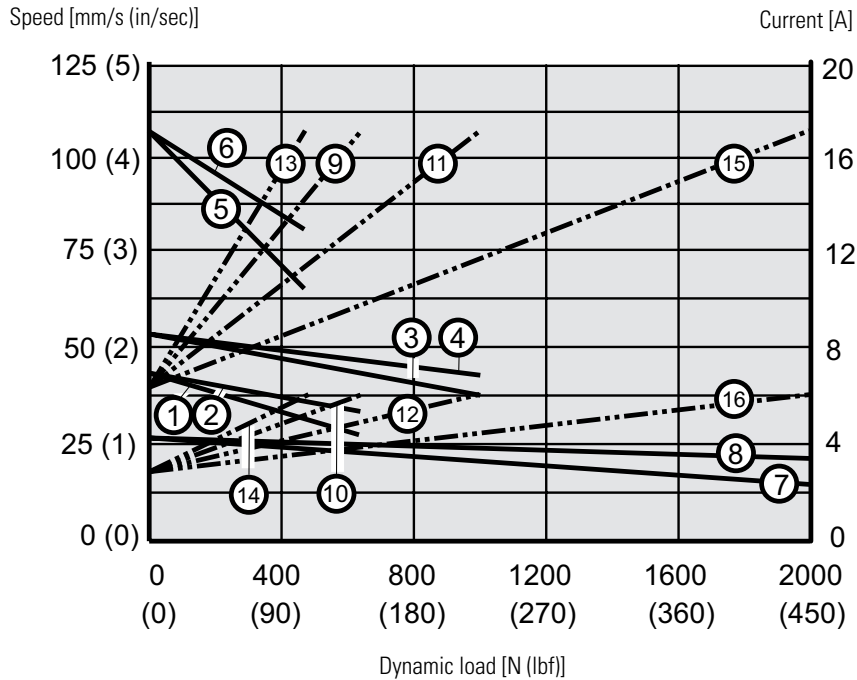

Speed

- 1: DT12-T68MxxxxxV(F)
- 2: DT24-T68MxxxxxV(F)
- 3: DT12-B61MxxxxxV(F)
- 4: DT24-B61MxxxxxV(F)
- 5: DT12-B62MxxxxxV(F)
- 6: DT14-B62MxxxxxV(F)
- 7: DT12-B65MxxxxxV(F)
- 8: DT24-B65MxxxxxV(F)
- ..

Current

- 9: DT12-T68MxxxxxV(F)
- 10: DT24-T68MxxxxxV(F)
- 11: DT12-B61MxxxxxV(F)
- 12: DT24-B61MxxxxxV(F)
- 13: DT12-B62MxxxxxV(F)
- 14: DT24-B62MxxxxxV(F)
- 15: DT12-B65MxxxxxV(F)
- 16: DT24-B65MxxxxxV(F)

# LM80-V – Ordering Key

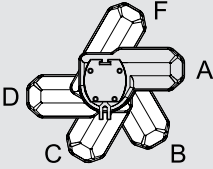
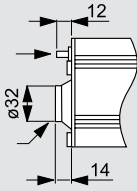
Ordering Key						
1	2	3	4	5	6	7
<b>DT12-</b>	<b>B62M-</b>	<b>100</b>	<b>A</b>	<b>C</b>	<b>V</b>	<b>X</b>
<p><b>1. Model and input voltage</b> DT12 - = LM80, 12 Vdc DT24 - = LM80, 24 Vdc</p> <p><b>2. Load torque capacity and screw type</b> T68M - = 250 N (56 lbf), trapezoidal screw B61M - = 400 N (90 lbf), ball screw B62M - = 180 N (40 lbf), ball screw B65M - = 750 N (169 lbf), ball screw</p> <p><b>3. Ordering stroke length</b> 050 = 500 mm 060 = 600 mm 070 = 700 mm 080 = 800 mm 090 = 900 mm 100 = 1000 mm 110 = 1100 mm 120 = 1200 mm 130 = 1300 mm 140 = 1400 mm 150 = 1500 mm</p>			<p><b>4. Motor orientation</b> A = 0° (standard) B = 60° C = 120° D = 180° F = 300°</p>  <p><b>5. Motor enclosure</b> C = with enclosure (IP44) U = no enclosure (IP33)</p> <p><b>6. Mounting orientation and spline safety feature</b> V = vertical with motor down, without spline safety feature F = vertical with motor down, with spline safety feature</p> <p><b>7. Options</b> X = no option H = manual override <sup>(1)</sup></p> <p>(1) Manual override dimensions</p>  <p>Hexagon socket with plastic cover (4 mm Allen key included)</p>			

# LM80-V – Accessories

## T-slot Mounting Kit

Designation	Part Number
M8 T-slot mounting kit	D680507

The T-slot mounting kit consists of four T-slot bolts, washers and nuts that fit in to the T-slot running along the profile. The T-slot mounting kit can be used to mount the unit or/and for attaching other components to the profile.

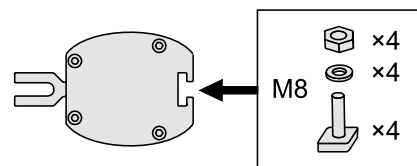

# LM80-V – Electrical Connections

## Without Option (standard)

Actuator supply voltage	[Vdc]	
DT12		12
DT24		24

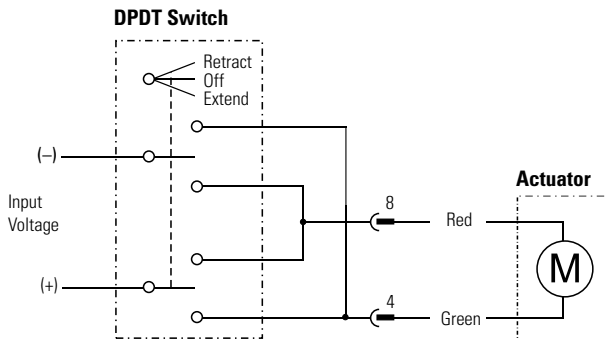

## Connector pin configuration (front view)

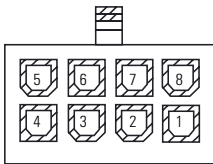

Connect the green lead (connector pin 4) to positive and red (pin 8) to negative to extend the actuator. Change polarity to retract the actuator.

# Glossary

## Acme Screw

Acme screws are self-locking and will not back-drive. They also withstand vibration and shock better than ball or worm screws and are used for applications with these characteristics. Also see "lead screw".

## Actuator Housing

The actuator housing provides environmental protection for the internal components and may also be a structural member of the actuator.

## Adapters

The front and rear adapters are the connection points for mounting most Thomson actuators. The front adapter is usually a cross hole but optionally may be a tapped hole, threaded rod, or universal rod end. The rear adapter may be cast into the actuator housing or held in place with a nut.

## Adjustable End of Stroke Limit Switches

The adjustable end of stroke limit switches may be moved to positions inside the full stroke of the actuator and will shut off the actuator when it reaches the limit switch. Also see "end of stroke limit switches".

## Anti-coast Brake/Electrical Brake

Depending on the load, AC ball screw actuators may coast to a stop when power is removed. This overrun is eliminated by an anti-coast brake or an electrical brake. The anti-coast brake (pawl type) will allow up to one revolution of the motor after power is removed. They are used on the Electrak GX AC. An electrical brake (electrically released) operates much faster after power is removed and allow less coast than the pawl type. Also see "brake".

## Anti-rotation Mechanism

A feature available on some actuators that resolves the restraining torque within the actuator. The extension tube will not rotate on actuators with this feature when driven without having the ends fixed.

## Auto Reset Thermal Switch

An auto reset thermal will switch off the motor if it becomes too warm which means that the motor has exceeded its maximum allowed duty cycle. When the motor has cooled off, the switch will close again automatically, and the motor will start to run if power is still being applied to it. Also see "duty cycle".

## Ball Screw

Ball screws are highly efficient and are used for high loads and speeds. Also see "lead screw".

## Brake

Actuators using an acme or worm screw are inherently self-locking, while ball screw driven actuators are not. To prevent ball screw actuators from backdriving, they incorporate an anti backdriving brake (holding brake). Ball screw actuators with an AC motor can also be equipped with an anti-coast brake. Also see "Anti-coast brake/electrical brake" and "holding brake".

## Capacitor

AC actuators use permanent split capacitor motors and require the use of a start/run capacitor in the control circuit to operate. The controls for AC actuators have the capacitor included in the control. For customer supplied controls, a separate capacitor is required, and the part number is included on the actuator product page.

## CE Compliance and Certification

All actuators sold in the EU are CE compliant, while some actuators sold outside of the EU may not be. If you order your actuator outside of the EU and need a CE compliance, contact the factory to verify availability and be sure to include the request on your order. Most AC actuators are UL listed as standard. UL has no standard for DC actuators under 48 Vdc.

## Compression Loads

See "Tension and Compression Loads".

## Controls

Controls can be external to the actuator and provide the actuator with the correct voltage, have either membrane or pendant operators, and some have position indicators.

## Cover Tube

The cover tube provides protection for the lead screw and provides protection and support for the extension tube. For the Electrak® PPA, the cover tube also provides the rear mounting connection.

## Customization

Even the most versatile actuator may not always suit all applications. But whatever your need is, our engineers are ready to help you to customize the actuators according to your requirements. We build more exclusive actuators than anyone else and have decades of experience in producing actuators to meet special needs.



# Glossary

## Duty Cycle

$$\text{Duty cycle} = \frac{\text{on time}}{(\text{on time} + \text{off time})}$$

Example: 15 seconds on, 45 seconds off

$$\frac{15 \text{ s}}{(15 \text{ s} + 45 \text{ s})} = 25\% \text{ duty cycle}$$

The duty cycle is a function of the maximum rated load and the ambient temperature. Ambient temperatures above the stated will affect the duty cycle negatively, while lower temperatures and/or lower load will affect it positively. Also see "on-time".

## Dynamic Load

The dynamic load rating is how much load the actuator will move when power is applied. Also see "load rating".

## Dynamic Braking

Dynamic braking is a feature which short circuits the motor windings at power off, resulting in a shorter coasting distance before the actuator comes to a complete stop. Dynamic braking can be accomplished on other DC actuators by wiring the control to short the motor leads when power is removed.

## Electronic Limit Switches (ELS)

Electronic Limit Switches is a current sensing function used in some actuator control models. The ELS senses the current and if it exceeds a preset level, the control cuts the power to the motor. This function can be used to detect and stop at the ends of the actuator stroke or to stop the actuator if it runs into an obstacle.

## Electronic Load Monitoring (ELM)

A built-in microprocessor inside the actuators continuously monitors the performance of the actuator. The microprocessor will stop the movement at the end of stroke, in case of mid stroke stall, at overload conditions or if the duty cycle is too high. It also eliminates the need of a clutch and provides dynamic braking.

## Encoder Feedback

Encoders provide a digital output signal that can be used to determine the position of the extension tube. An encoder equipped actuator must return to a "home" position if power is removed and restored in order to reset its starting point. Also see "potentiometer feedback".

## End of Stroke Limit Switches

End of stroke limit switches are incorporated in some actuator models, either as standard or as an option, that will shut off power when the end of stroke is achieved. Also see "fixed end of stroke limit switches" and "adjustable end of stroke limit switches".

## End Play (Backlash)

The stack up of tolerances within the lead screw assembly and gearing allowing some linear movement of the extension tube without rotating the motor. Typical end play or backlash varies by model. The range is 0.3 to 2.0 mm (0.012 - 0.08 inch).

## Extension Tube

The extension tube slides in and out of the actuator and is connected via the front adapter to the load being moved or positioned.

## Fixed End of Stroke Limit Switches

The fixed end of stroke limit switches allow the full stroke of the actuator to be used and will shut off power when the end of stroke is achieved. Also see "end of stroke limit switches".

## Holding Brake

All acme, worm or trapezoidal screw driven actuators are inherently self-locking, while ball screw driven ones incorporate an anti back-driving brake (holding brake) that engages when the actuator has come to a complete stop. Also see "brake".

## Input Voltage

The nominal voltage required to operate the actuator. All actuators will accept at least a  $\pm 10\%$  variation of the nominal voltage, but a change in the voltage will result in a change of the speed of DC actuators. Controls are available that accept 115 or 230 Vac input and provide 24 Vdc output to operate 24 Vdc actuators.

## Inrush Current

Inrush current is a short current peak that appears at the start of an actuator as the motor tries to get the load moving. Typically, the inrush current will last between 75 to 150 milliseconds and can be up to three times higher (on a low-level switched actuator 1.5 times higher) than the current for the actuator and load. Batteries have no problem delivering the inrush current, but if using an AC power supply, it is important to size it to handle the inrush current.

## Installation Instructions

Each actuator has an installation manual to answer typical questions about mounting and wiring the actuators.

## IP Rating

See "protection class".

## Lead Screw

Actuators use four different types of lead screws depending on the configuration and load requirements of the actuator. Ball screws are highly efficient and used for high loads and speeds. Acme, worm and trapezoidal screws are self-locking and will not backdrive. Acme and trapezoidal screws withstand vibration and shock better than the other and are used for applications with these characteristics.

# Glossary

## Lifetime Expectancy

Life is very complex to calculate and depends on many parameters. Some of the more important parameters includes load, stroke length, operation temperature and how often the overload clutch is operated. Contact customer service for more information.

## Lifting Columns

Lifting columns provide a stable base for adjusting the height of tables or platforms. The column provides both the lifting force and the ability to resolve high moment forces from off axis loads.

## Linear Actuators

Actuators providing a linear thrust via an extension tube to lift, lower, push, pull or position a load.

## Load Rating

The load rating is the minimum amount of force the actuator will provide during its lifetime. The load rating of all rod style actuators is the same for both compression and tension loads. Also see "dynamic load", "static load" and "tension and compression load".

## Low Level Switching

Low level switching allows you to control the direction of the actuator motion by using low level inputs on the actuator instead of having to switch the much higher motor current.

## Manual Override (Hand Wind)

Allows manual operation of the actuator in both directions in case of a power failure. The actuator accepts a standard hexagon key to rotate the motor in either direction. Optional on some models.

## Maximum On Time

The maximum amount of time an actuator may operate without stopping to "cool off". For high load and long stroke actuators, this may be one extend and retract cycle. The actuator should not exceed 25% duty cycle at full rated load. If no maximum on time is stated, the maximum on time is equal to one full cycle at the maximum dynamic load for the actuator in question.

## Mounting

Electrak® actuators are quickly and easily mounted by slipping pins through the holes on each end of the unit and into brackets on the machine frame and the load. PPA actuators are mounted by the rear trunnions on the cover tube and the clevis on the extension tube. Solid pins provide maximum holding strength, and a retaining or cotter pin on each end will prevent the pin from falling out of its mounting bracket. Roll or spring type mounting pins should be avoided. The mounting pins must be parallel to each other as shown (Fig. a). Pins which are not parallel may cause the actuator to bind. The load should act along the axis of the actuator since off center loads may cause binding (Fig. b).

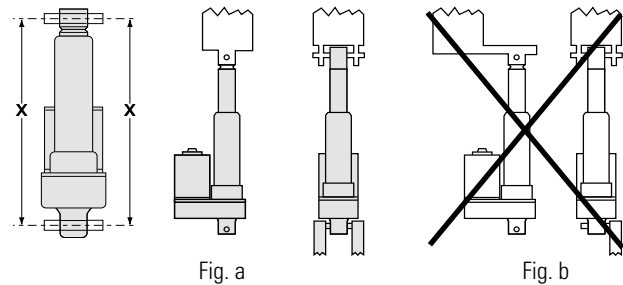

## Non-driven Actuators

Actuators supplied without a motor and driven manually or by a customer supplied motor.

## On-time

The on-time is the time that the motor runs for between two stops. The maximum on-time is the maximum time the motor is allowed to run for between two stops. Sometimes the maximum on-time is the limiting factor rather than the duty cycle rating. Also see "duty cycle".

## Operating and Storage Temperature

The operating temperature is the range in which the actuator may be safely operated. For the high end of the range, the duty cycle will be lower than 25%. All actuators can be stored or transported at the same temperature as the operating temperature. Contact customer support if the operating temperature will be exceeded during storage or transportation.

## Overload Clutch

Electrak HD, 050, GX and PPA Series linear actuators are protected by a load limiting mechanical clutch which prevents the motor from stalling at either end of the actuator stroke. It will also slip when the factory-set load limit is exceeded. The clutch is a ball detent design, assuring a consistent slip point and long life.

## Potentiometer Feedback

Potentiometers provide an analog output signal that can be used to determine the position of the extension tube. A potentiometer will "remember" its position if power is removed and restored. Also see "encoder feedback"

## Protection Class

The protection class refers to the environmental rating of the enclosure, International Protection Marking (IP) ratings are commonly referenced standards that classify electrical equipment using standard tests to determine resistance to ingress of solid objects and liquids. The first digit applies to airborne contaminants and the second digit (and sometimes a third letter) to water/moisture.

# Glossary

- IP33: protected against the penetration of solid objects with a diameter greater than 12 mm and against direct sprays of water up to 60 degrees from vertical.
- IP44: protected against the penetration of solid objects with a diameter greater than 1 mm and against water sprayed from any direction.
- IP45: protected against the penetration of solid objects with a diameter greater than 1 mm and low pressure water jets from any direction.
- IP51: protected from dust and vertical dripping water/condensation.
- IP52: protected from dust and dripping water/condensation falling at an angle up to 15 degrees from vertical.
- IP56: protected from dust and high pressure water jets from any direction.
- IP65: dust tight and protected against low pressure water jets from any direction.
- IP66: dust tight and protected against high pressure water jets from any direction.
- IP67: dust tight and protected against the effect of immersion in water between 150 mm (5.9 inch) and 1 meter (39.4 inch).
- IP69K: dust tight and protected against the effect of high pressure washing with hot water from any direction.

## Pulse Width Modulation (PWM)

Pulse width modulation control works by switching the power supplied to the motor on and off rapidly. The DC voltage is converted to a square-wave signal, alternating between fully on and zero, giving the motor a series of power “kicks”. If the switching frequency is high enough, the motor runs at a steady speed due to its fly-wheel momentum. By adjusting the duty cycle of the signal (modulating the width of the pulse, hence the ‘PWM’), the time fraction it is “on”, the average power can be varied, and hence the motor speed. Note: Actuators with built-in electronics and CE filters will be affected negatively by the PWM modulation and should not be used together. Contact customer support for more information.

## REACH

REACH is a European Union regulation concerning the Registration, Evaluation, Authorization and restriction of Chemicals. It makes manufacturers and importers who place chemicals on the market responsible for understanding and managing the risks associated with their use.

## Restraining Torque

The torque which is developed between the clevis on the extension tube and rear mount (clevis or trunnion) when the unit extends or retracts and ratchets the clutch (Fig. c). This means that if the ends are not fixed by a method that can handle the restraining torque, the extension tube will rotate instead of moving. However, units with anti-

rotation mechanism are internally restrained and can therefore be run in and out without having to be fixed in the ends. Also see “anti-rotation mechanism”.

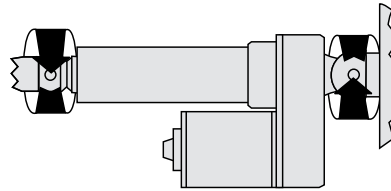

Fig. c

## Rodless Actuators

Rodless actuators provide support for the load as well as thrust. The load is supported and moved by a carriage on the actuator rather than pushed or pulled by an extension rod. Rodless actuators are ideal for applications requiring long strokes (up to 1500 mm), high speeds (up to 110 mm/s), movement of the load within the shortest envelope possible or the load supported by the actuator.

## RoHS Compliance

All actuators, controls and accessories sold in the EU are RoHS compliant unless otherwise stated, while products sold outside of the EU may not be. If you order an actuator outside of the EU and need it to be RoHS compliant, contact the factory to verify availability and be sure to include the request on your order.

## Rotary Actuators

Actuators providing a rotary output to position a load, turn a winch, or rotate a gear or sprocket.

## Service and Maintenance

Actuators are generally maintenance free. Electrak GX have repair kits available from your local distributor or OEM.

## Side Loading

Side loading occurs when the extension tube/moving member is subjected to loads from the side. Most actuators cannot handle any side loads, and a proper design of the application should eliminate any side loads or keep it within the permissible limits.

## Sizing and Selection

The Thomson web site ([www.thomsonlinear.com](http://www.thomsonlinear.com)) includes an online tool that can be used to walk through the decision process for picking the best actuator and get the ordering data for your choice.

## Speed

DC actuators have a direct load/speed relationship. As the load increases, the speed decreases. There are curves on each product page to show the speed from no load to full rated load. AC actuators have little speed fluctuations based on load but there are load/speed curves on all the AC actuator product pages.

# Glossary

## Spline Safety Function

An optional safety function on the rodless actuator (LM80) that will stop downward motion in case the carriage (the moving member) collides with an obstacle. The motor will keep running but the carriage will stand still and not pull down on the obstacle. When reversing the motor rotation, the carriage will automatically start to move upwards again.

## Static Load

The static load rating is how much load the actuator will hold with power off. The static load rating is normally twice the dynamic load rating. Also see "load rating". If nothing else is stated, the static load rating is for the actuator extension tube being fully retracted. The static load rating will decrease as the tube extends.

## Synchronous Operation

Normally motor speed cannot be controlled with enough precision to ensure that the actuators will remain synchronized, and a binding effect could take place. However, there are some solutions. Non-driven actuators may be mechanically linked and thereby synchronized. Actuators equipped with an encoder can be synchronized using controls designed for synchronous operation as long as there is no onboard electronics preventing PWM operation. Electrak HD models with SYN option have a built in control which enables synchronized operation between two or more Electrak HD SYN units of the same type.

## Tension and Compression Load

A tension load tries to stretch the actuator, and a compression load tries to compress the actuator (Fig. d). Most actuators can manage the same tension and compression load. Also see "load rating". With bi-directional loads, the end play of the actuator extension tube may need to be taken into consideration when using the actuator for positioning tasks.

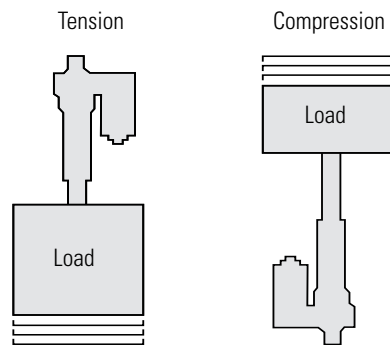

Fig. d

## Trapezoidal Screw

Screw type with similar characteristics as an acme screw. This type of screw is used in LM80. Also see "acme screw" and "lead screw".

## Vent Tube

Electrak® 050 actuators have a breather tube in the wiring harness to allow the actuator to operate without creating a vacuum and drawing water through the seals on the cover tube.

## Voltage Drop

Long leads/cables between the power source and the actuator will result in a voltage drop for DC units. This voltage drop can cause malfunction and are avoided by sizing the leads in accordance with the following lead cross section selection table. The table is based on an ambient temperature of 30 °C (86 °F) or less. A higher ambient temperature may result in the need for a greater lead cross section.

**Lead Cross Section Selection Table [mm<sup>2</sup> (AWG)]**

Current draw [A]	Cable length [m]	Actuator input voltage [Vdc]		
		12	24	36
0 - 10	0 - 3	2.5 (14)	1.5 (16)	1.5 (16)
	3 - 6	2.5 (14)	1.5 (16)	1.5 (16)
	6 - 10	1.5 (16)	2.5 (14)	1.5 (16)
10 - 15	0 - 3	2.5 (14)	2.5 (14)	1.5 (16)
	3 - 6	2.5 (14)	2.5 (14)	1.5 (16)
	6 - 10	2.5 (14)	-	-
15 - 20	0 - 3	2.5 (14)	-	-
	3 - 6	6 (12)	-	-
	6 - 10	2.5 (14)	-	-
20 - 28	0 - 3	6 (12)	-	-
	3 - 6	10 (8)	-	-
	6 - 10	6 (12)	-	-
28 - 35	0 - 3	6 (12)	-	-
	3 - 6	10 (8)	-	-
	6 - 10	10	-	-

## Worm Screw

Worm screws are self-locking and will not back-drive. This type of screw is used in Electrak 050, Throttle and Max Jac. Also see "lead screw".

## USA, CANADA and MEXICO

Thomson  
203A West Rock Road  
Radford, VA 24141, USA  
Phone: +1 540 633 3549  
Fax: 1 540 633 0294  
E-mail: thomson@thomsonlinear.com  
Literature: literature.thomsonlinear.com

## EUROPE

### United Kingdom

Thomson  
Office 9, The Barns  
Caddsdow Business Park  
Bideford, Devon, EX39 3BT  
Phone: +44 1271 334 500  
E-mail: sales.uk@thomsonlinear.com

### Germany

Thomson  
Nürtinger Straße 70  
72649 Wolfschlugen  
Phone: +49 7022 504 403  
Fax: +49 7022 504 405  
E-mail: sales.germany@thomsonlinear.com

### France

Thomson  
Phone: +33 243 50 03 30  
Fax: +33 243 50 03 39  
E-mail: sales.france@thomsonlinear.com

### Italy

Thomson  
Via per Cinisello 95/97  
20834 Nova Milanese (MB)  
Phone: +39 0362 366406  
Fax: +39 0362 276790  
E-mail: sales.italy@thomsonlinear.com

### Spain

Thomson  
E-mail: sales.esm@thomsonlinear.com

### Sweden

Thomson  
Estridsväg 10  
29109 Kristianstad  
Phone: +46 44 24 67 00  
Fax: +46 44 24 40 85  
E-mail: sales.scandinavia@thomsonlinear.com

## ASIA

### Asia Pacific

Thomson  
E-mail: sales.apac@thomsonlinear.com

### China

Thomson  
Rm 805, Scitech Tower  
22 Jianguomen Wai Street  
Beijing 100004  
Phone: +86 400 606 1805  
Fax: +86 10 6515 0263  
E-mail: sales.china@thomsonlinear.com

### India

Thomson  
c/o Portescap India Pvt Ltd  
1 E, first floor, Arena House  
Road no 12, Marol Industrial Area,  
Andheri (E), Mumbai 400093 India  
E-mail: sales.india@thomsonlinear.com

### Japan

Thomson  
Minami-Kaneden 2-12-23, Suita  
Osaka 564-0044 Japan  
Phone: +81 6 6386 8001  
Fax: +81 6 6386 5022  
E-mail: csjapan@scgap.com

### South Korea

Thomson  
3033 ASEM Tower (Samsung-dong)  
517 Yeongdong-daero  
Gangnam-gu, Seoul, South Korea (06164)  
Phone: + 82 2 6001 3223 & 3244  
E-mail: sales.korea@thomsonlinear.com

## SOUTH AMERICA

### Brasil

Thomson  
Av. João Paulo Ablas, 2970  
Jardim da Glória - Cotia SP - CEP: 06711-250  
Phone: +55 11 4615 6300  
E-mail: sales.brasil@thomsonlinear.com

[www.thomsonlinear.com](http://www.thomsonlinear.com)

Linear\_Actuators\_CTEN-0011-02 | 20190905TJ

Specifications are subject to change without notice. It is the responsibility of the product user to determine the suitability of this product for a specific application. All trademarks property of their respective owners. © 2019 Thomson Industries, Inc.



DISTRIBUIDOR  
AUTORIZADO

MEX (55) 53 63 23 31 MTY (81) 83 54 10 18  
QRO (442) 1 95 72 60 ventas@industrialmagza.com

**THOMSON**

*Linear Motion. Optimized.™*